

## 5-CH BTL DRIVER FOR CD PLAYER WITH 5V OUTPUT VOLTAGE

### DESCRIPTION

The SA9259 is a 5-channel motor driver for driving focus actuator, tracking actuator, sled motor, spindle motor and loading motor in products such as CD-PLAYER/VIDEO-CD drivers.

### FEATURES

- \* Wide operating supply voltage range: 6V~13.2V
- \* Thermal shutdown circuit on chip
- \* Built-in 5V regulator controller.
- \* Level shift circuit on chip.
- \* Built-in Mute mode.
- \* Built-in Loading motor speed control circuit.
- \* Built-in 1 phase, full-wave, linear DC motor driver.

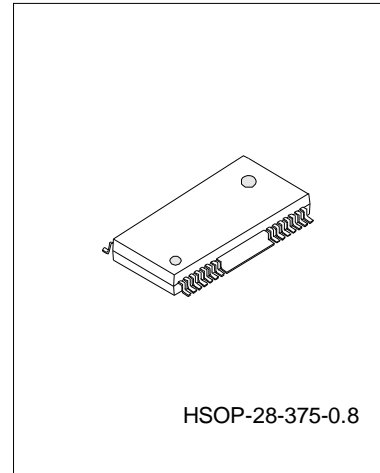

### APPLICATIONS

- \* CD-PLAYER
- \* VIDEO-CD
- \* CAR-CD

### ORDERING INFORMATION

Device	Package
SA9259	HSOP-28-375-0.8

### BLOCK DIAGRAM

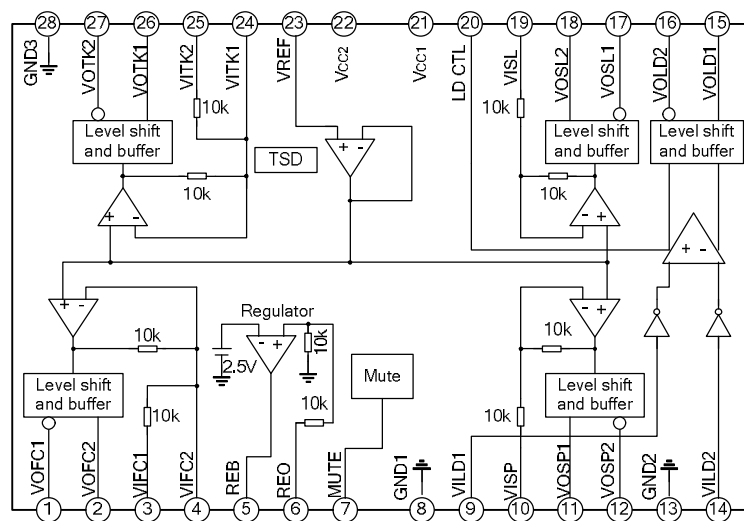

### ABSOLUTE MAXIMUM RATINGS (T<sub>amb</sub>=25°C)

Characteristics	Symbol	Rating	Unit
Maximum supply voltage	V <sub>CCMAX</sub>	18	V
Power dissipation	P <sub>D</sub>	@1.7	W
Operating temperature	T <sub>OPR</sub>	-40~+85	°C
Storage temperature	T <sub>STG</sub>	-55~+150	°C
Maximum current output	I <sub>OMAX</sub>	1	A

**NOTE: @**

1. When mounted on 76mm x 114mm x 1.57mm PCB (Phenolic resin material).
2. Power dissipation reduces 13.6mW / °C for using above Tamb=25 °C

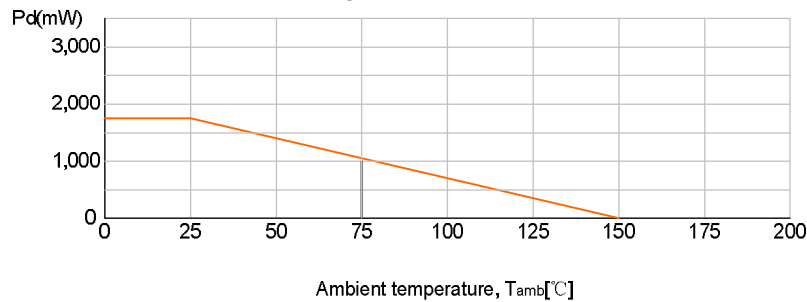
**ELECTRICAL CHARACTERISTICS** (Unless otherwise noted, Tamb=25°C, VCC=8V, RL=8Ω, f=1kHz)

Characteristics	Symbol	Test condition	Min.	Typ.	Max.	Unit
Operating Voltage	VCC		6	8	14	V
Quiescent Current	ICCQ	Under no-load	4.0	5.5	9.0	mA
Mute-on Current	IMUTE	Pin 7=GND	--	3.0	4.0	mA
Mute-on Voltage	VMON	--	--	--	0.7	V
Mute-off Voltage	VMOFF	--	2	--	--	V
<b>Regulator part</b>						
Output Voltage	VREG	IL=100mA	4.7	5.1	5.4	V
Load Regulation	ΔVRL3	IL=0→200mA	-50	0	50	mV
Line Regulation	ΔVCC	VCC=6→13V, IL=100mA	-20	0	80	mV
<b>Driver part (except for loading motor driver)</b>						
Input Offset Voltage	VIO	--	-15	--	15	mV
Output Offset Voltage1	VOO1	--	-50	--	50	mV
Maximum Source Current 1	ISOURCE1	RL=8Ω→ GND	0.25	0.4	--	A
Maximum Sink Current 1	ISINK1	RL=8Ω→ VCC	0.25	0.4	--	A
Maximum Output Voltage 1	VOM1	VIN=0V	3.8	4.5	--	V
Maximum Output Voltage 2	VOM2	VIN=5V	--	-4.5	-3.7	V
Closed-loop Voltage Gain	AVF	VIN=0.1VRMS	5	6.5	8	dB
Ripple Rejection Ratio	RR	VIN=0.1VRMS, f=120Hz	40	60	--	dB
Slew Rate	SR	120Hz, VIN=1VRMS, square wave	1	2	--	V/μs
<b>LOADING MOTOR DRIVER PART (Unless otherwise specified, VCTL=opened)</b>						
Output Voltage 1	VO1	VPIN9=5V, VPIN14=0V, RL=45Ω, VCTL=3.5→4.5V	2.5	3.3	3.8	V
Output Voltage 2	VO2	VPIN9=0V, VPIN14=5V, RL=45Ω, VCTL=3.5→4.5V	2.5	3.3	3.8	V

(To be continued)

(Continued)

Characteristics	Symbol	Test condition	Min.	Typ.	Max.	Unit
Output Voltage Regulation 1 (CTL)	VOCTL1	VCTL=1.5→2.5V, VPIN9=5V VPIN14=0V, RL=45Ω	0.5	1.0	1.5	V
Output Voltage Regulation 2 (CTL)	VOCTL2	VCTL=1.5→2.5V, VPIN9=0V VPIN14=5V, RL=45Ω	0.5	1.0	1.5	V
Load Regulation 1	ΔVRL1	IL=100→400mA, VPIN9=5V, VPIN14=0V	--	300	700	mV
Load Regulation 2	ΔVRL2	IL=100→400mA, VPIN9=0V, VPIN14=5V	--	300	700	mV
Output Offset Voltage 2	VOO2	VPIN9=5V, VPIN14=5V	-50	--	50	mV
Output Offset Voltage 3	VOO3	VPIN9=0V, VPIN14=0V	-50	--	50	mV

### PIN CONFIGURATION

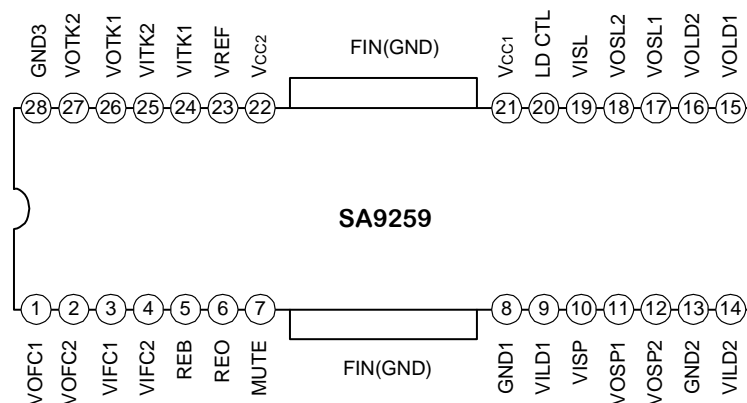

### PIN DESCRIPTION

Pin No.	Pin name	Pin descriptions
1	VOFC1	Focus output 1(-)
2	VOFC2	Focus output 2 (+)
3	VIFC1	Focus input 1
4	VIFC2	Focus input 2 (Adjustable)
5	REB	Regulator base
6	REO	Regulator output, 5V
7	MUTE	Mute
8	GND1	Ground 1
9	VILD1	Loading input 1
10	VISP	Spindle input

(To be continued)

(Continued)

Pin No.	Pin name	Pin descriptions
11	VOSP1	Spindle output (+)
12	VOSP2	Spindle output (-)
13	GND2	Ground 2
14	VILD2	Loading input 2
15	VOLD1	Loading output 1(+)
16	VOLD2	Loading output 2 (-)
17	VOSL1	Sled output (-)
18	VOSL2	Sled output (+)
19	VISL	Sled input
20	LD CTL	Loading motor speed control
21	VCC1	Supply voltage 1
22	VCC2	Supply voltage 2
23	VREF	2.5V bias
24	VITK1	Tracking input 1 (Adjustable)
25	VITK2	Tracking input 2
26	VOTK1	Tracking output 1 (+)
27	VOTK2	Tracking output 2 (-)
28	GND3	Ground 3

## FUNCTION DESCRIPTION

### 1. MUTE

- This IC has a built in thermal shutdown circuit that mutes the output current when the chip temperature reaches 175°C (typ.). The hysteresis is set to 25°C (typ.), so the driver circuits start up again when the chip temperature falls to 150°C (typ.).
- The mute circuit logic is active low.
- The circuit is muted during thermal shutdown and during the mute-on state .In each case, only the drivers are muted. The output pins remain at the internal bias voltage, roughly  $(V_{CC} - V_{BE}) / 2$ .
- Bias pin (pin23) should be pulled up to more than 1.6V. In case the bias pin voltage is pulled down below 1.4V (Typ), the output current is muted.

### 2. Regulator

This is a typical series regulator that generates a reference voltage internally. A PNP low saturation type transistor must be connected.

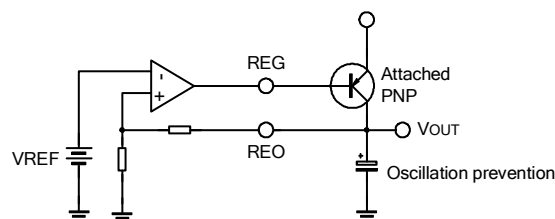

- VREF BG is the output voltage of the bandgap standard bias circuit and is also the standard voltage of the regulator.

- Periphery circuit is composed of bipolar, KSB722 and one 100μF capacitor. The capacitor needs good temperature characteristics to remove the ripple.
- The output voltage V<sub>OUT</sub> is decided by the following formula:

$$V_{OUT} = V_{REF} \cdot \frac{R_2 + R_3}{R_3} = 2.5 \times 2 = 5V$$

$$R_2 = R_3$$

### 3. LOADING MOTOR DRIVER

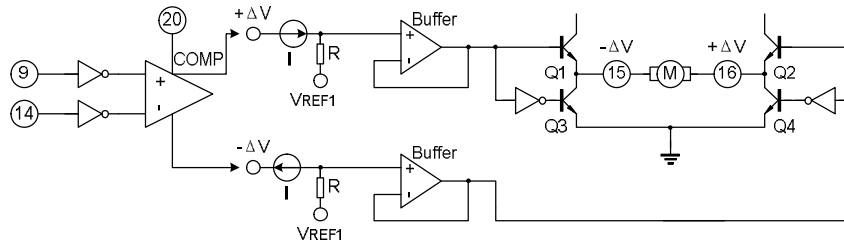

- Input voltage (5V and 0V) or (0V and 5V) to pin 9 and pin 14.
- After input the voltage to pin 9 and pin 14, decide the output of comparator according to the voltage state.
- As the above figure, the voltage warp  $\Delta V$ ,  $[V_{REF1} + (I \times R)] - [V_{REF1} - (I \times R)]$ , used for the motor. And the direction of the motor is decided by the voltage warp  $+\Delta V$  and  $-\Delta V$ .
- The output characteristics are as follows:

FWD(pin9)	REV(pin14)	VOTR+(pin15)	VOTR-(pin16)	Function
L	L	$(V_{CC} - V_{be}) / 2$	$(V_{CC} - V_{be}) / 2$	Stop mode
L	H	L	H	Reverse mode
H	L	H	L	Forward mode
H	H	$(V_{CC} - V_{be}) / 2$	$(V_{CC} - V_{be}) / 2$	Stop mode

### 4. LOADING MOTOR SPEED CONTROL

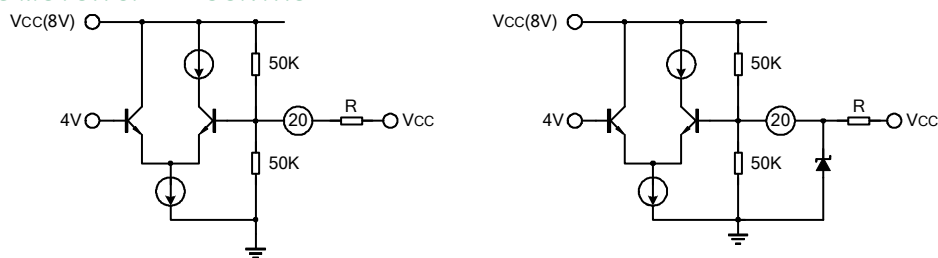

- If the torque of the loading motor is too low when it is used with the pin #20 open, then it should be used as the above diagram.
- The desired torque could be obtained by selecting the appropriate resistor R as shown in the left diagram.
- If it is necessary, the zener diode can be used as in the right diagram.
- The maximum torque is obtained when the applied voltage at pin #20 is about 6.8V (at V<sub>CC</sub>=8V).

### 5. Connect a by-pass capacitor, 0.1μF between the supply voltage source.

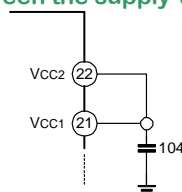

6. Radiation fin is connecting to the internal GND of the package.

Connect the fin to the external GND.

**ELECTRICAL CHARACTERISTICS CURVES**

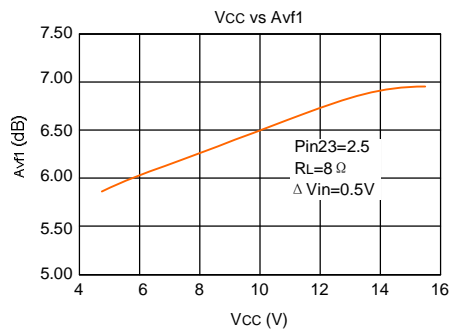
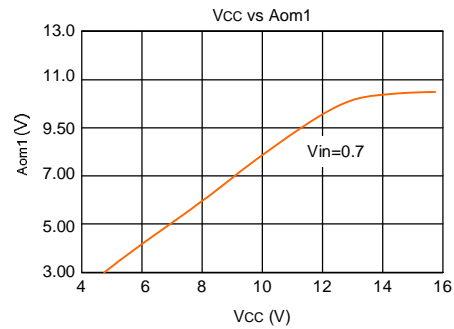
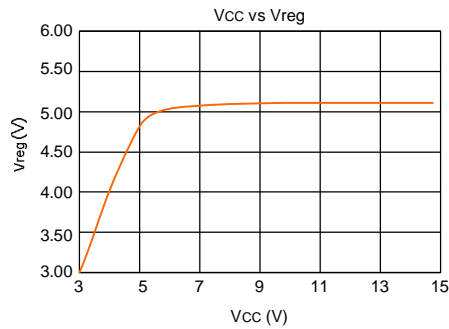
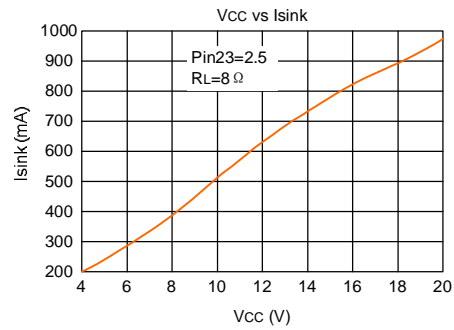
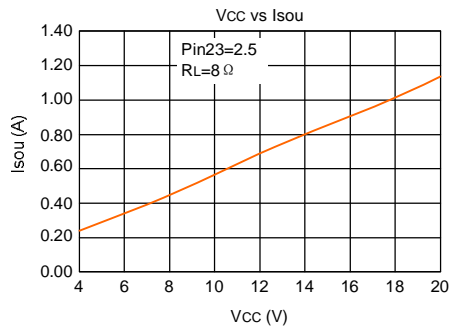
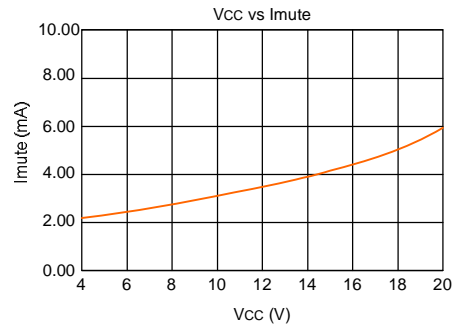
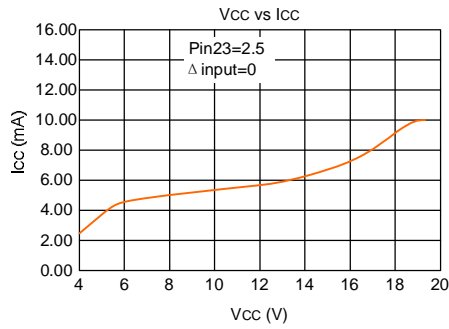

**TEST CIRCUIT**

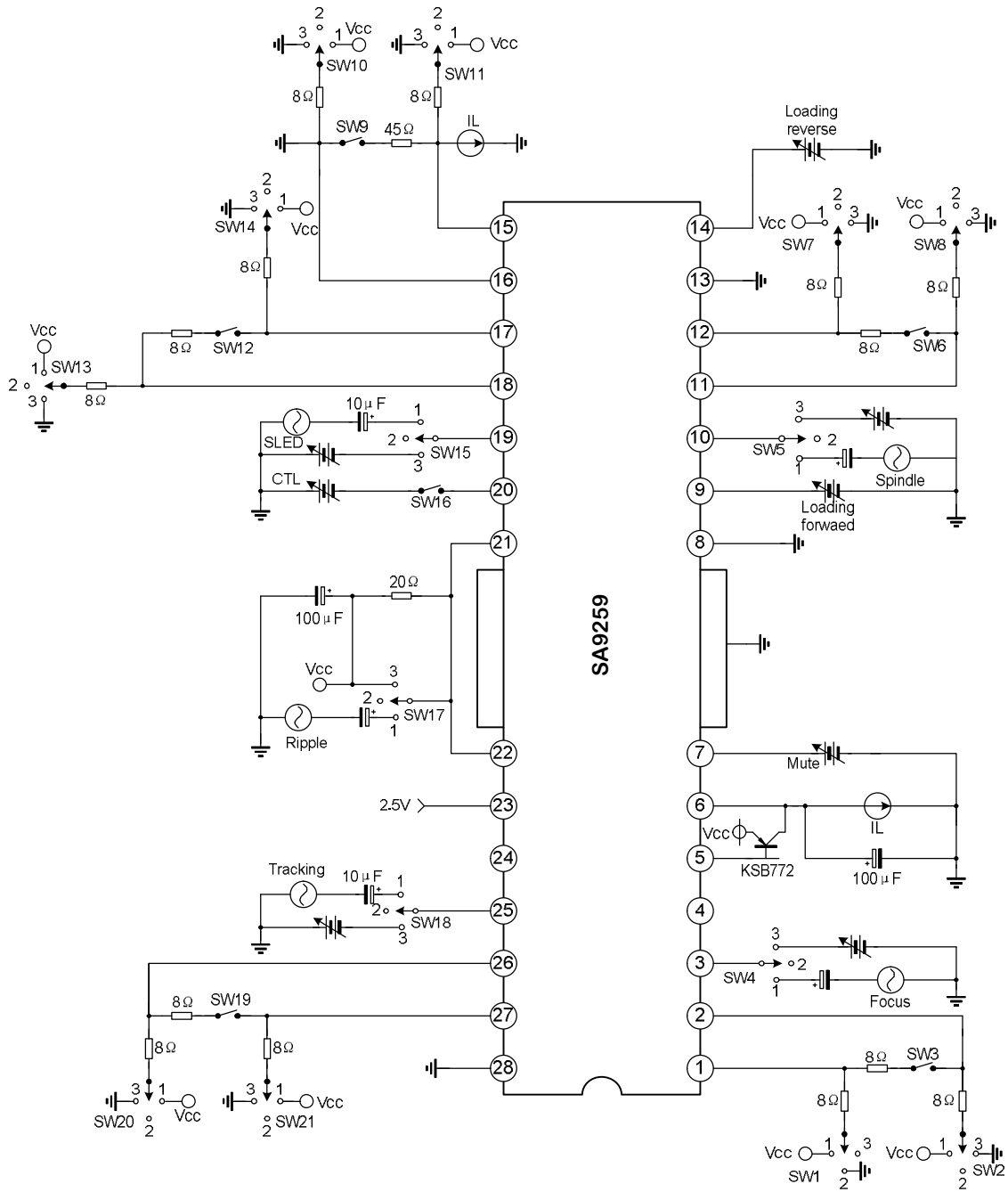

TYPICAL APPLICATION CIRCUIT

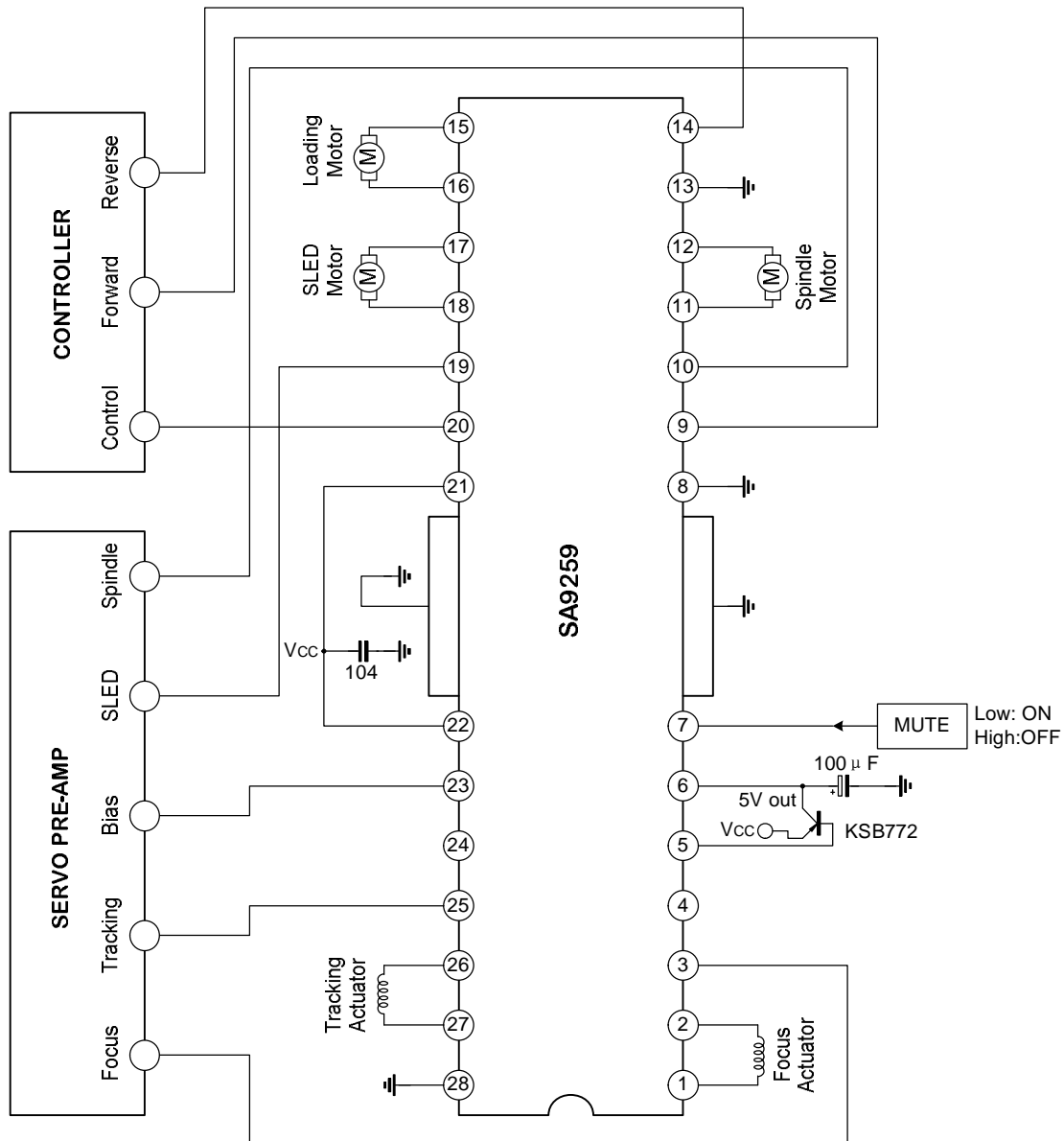



PACKAGE OUTLINE

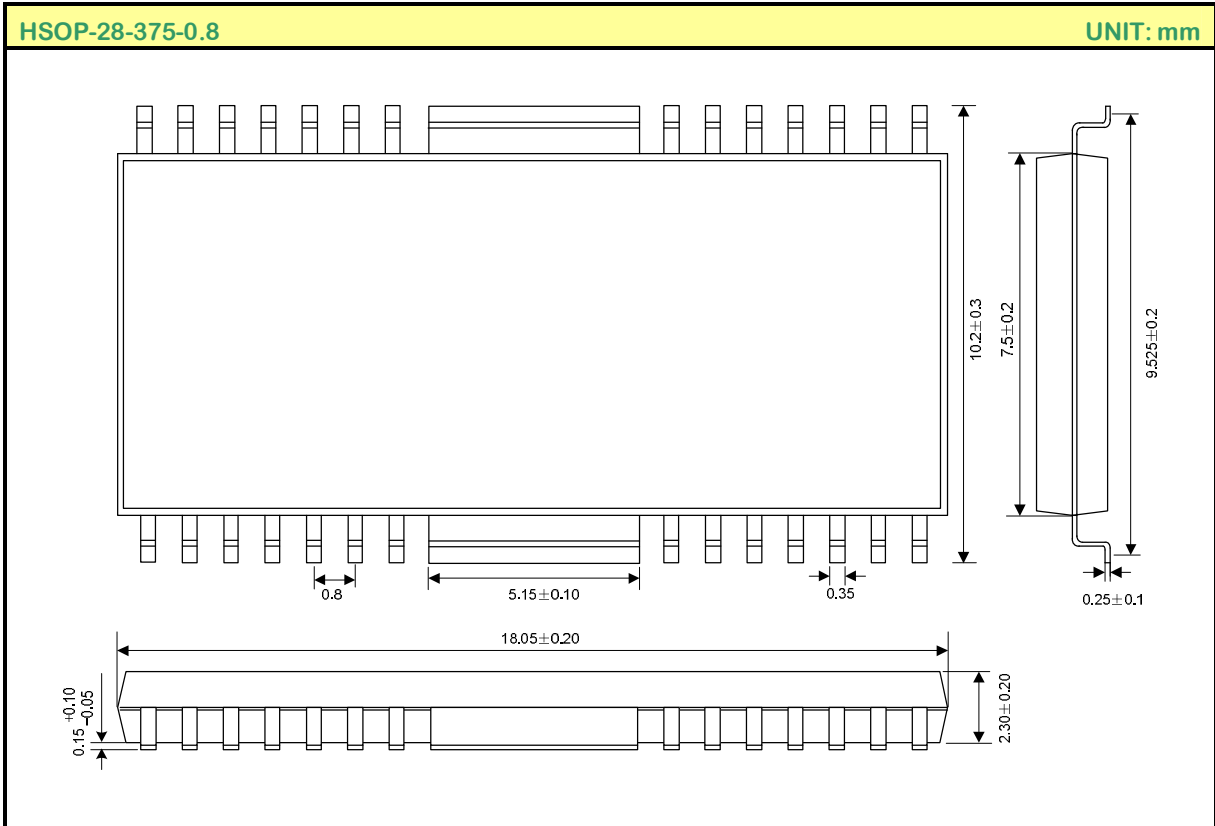



ATTACHMENT

Revision History

Data	REV	Description	Page
2003.01.08	1.0	Original	
2005.12.22	1.1	Modify the "BLOCK DIAGRAM" and "ELECTRICAL CHARACTERISTICS"	
2006.12.05	1.2	Modify the "ABSOLUTE MAXIMUM RATINGS"	
2007.01.26	1.3	Modify the "ELECTRICAL CHARACTERISTICS"	