

INTRODUCTION

The Cermetek CH1837A/F Data Access Arrangement (DAA) is designed to meet the performance requirements of 33.6Kbps modems, such as V.34bis, for embedded applications. The CH1837A/F meets or exceeds the requirements for V.34 and can be used in lower speed applications as well. The isolation voltage and surge protection meets, as a minimum, North American UL1950 Edition 3 (USA) and CSA C22.2 950 (Canada) requirements. Further, the CH1837A/F has been tested to meet FCC Part 68 and is Canadian DOT CSA CS-03 Part I approvable.

The CH1837A/F is compatible with all popular V.34bis modem/fax chip sets. Application examples are included in this datasheet. The CH1837A/F offers a Quick-to-Market DAA solution for high performance modem designs.

The CH1837A/F is exceptionally well suited for voice-over-data (VoIP) and other internet-based telephony and data communication applications.

For those applications not requiring a two to four wire hybrid converter circuit, the CH1838A provides all the features of the CH1837A/F (except the hybrid converter) while offering some cost savings. Note that the CH1838A is a special order product only. Consult Cermetek for availability and delivery.

FEATURES

- Low Profile
- Complete DAA function
- Compatible with most popular V.34bis modem chip sets
- Ring detection circuitry included
- Built-in 2-wire to 4-wire conversion circuitry (CH1837A/F only)
- UL1950 Edition 3 Listed and CSA C22.2 950 Compliant
- 1500 VAC RMS Isolation
- 2122V peak surge protection
- +5V low power operation
- Differential transmission, VoIP applications
- Compatible with V.34bis, V.32bis, V.32, V.22bis, and V.22
- FCC Part 68 (USA) and DOT CSA CS-03 Part I (Canada) Approvable

DESCRIPTION OF FUNCTIONAL BLOCKS AND DISCUSSION OF BASIC OPERATIONS

Figure 1 contains a functional block drawing of the CH1837A/F. Each CH1837A/F product consists of:

- 1) Isolation barrier.
- 2) Off-Hook Switch/Ring Detect circuit.
- 3) PSTN Line Surge and High Voltage Protection circuitry.
- 4) 2-to-4 Wire Conversion circuit.

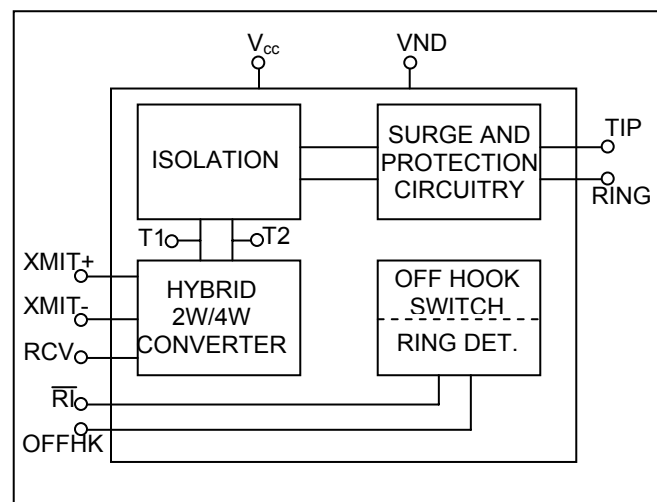

Figure 1. Function Block Diagram of CH1837A/F.

Figure 2 contains a functional block drawing of the CH1838A. Each CH1838A product consists of:

- 1) Isolation Barrier.
- 2) Off-hook Switch/Ring Detect circuit.
- 3) PSTN Line surge and High Voltage Protection Circuitry.

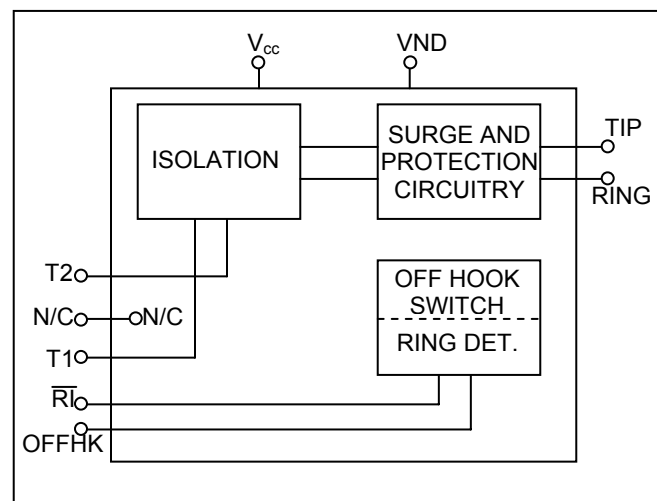

Figure 2. Function Block Diagram of CH1838A.

Ring Detection. To announce an incoming call, the telephone company's central office (CO) applies an AC ringing signal to the PSTN line. The CH1837A/7F/8A is designed to detect this signal. The CH1837A/7F/8A uses the AC ring signal to produce a square wave pulse train output at the CH1837A/7F/8A RI pin. This pulse train is the same frequency as the incoming AC ring signal and is typically 20 Hz. Figure 3 shows external filtering which may be employed to provide an envelope indication of the ring signal using the CH1837A/7F/8A RI output. The ring detection circuit in the CH1837A/7F/8A family is designed to deter false indications caused by pulse dialing or noise on the PSTN line.

Additionally, the RI output of the CH1837A/7F/8A is diode protected thereby allowing an external pull-up resistor ($R > 100k$ ohms) to +5V to be utilized to activate the ring detection circuit when the CH1837A/7F/8A is not connected to power. This can be handy for designs in which power consumption is of concern. When circuited in this manner, there is virtually no current draw until a ring signal is present. Refer to Figure 4.

RI Output: Opt coupler, 30KΩ pull-up, Active LOW
 Square wave 15-68HZ (TIP. 20Hz)
 Sensitivity: 38Vrms across TIP and RING

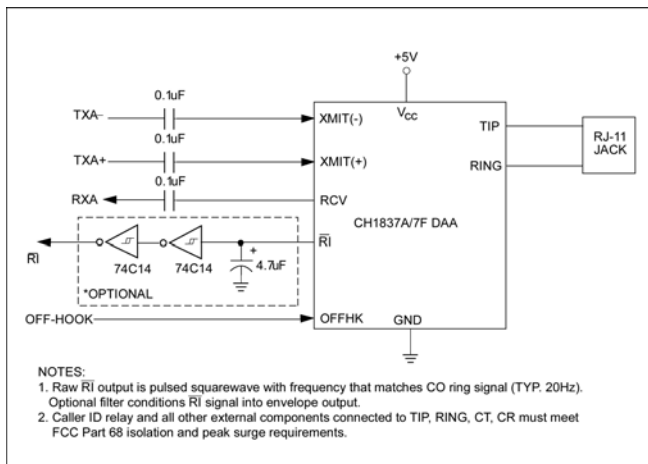

Figure 3. Typical Application.

Hook Switch Control.

The OFFHK input is used to toggle the CH1837A/7F/8A from On-Hook to Off-Hook and back to On-Hook.

When the OFFHK input is TTL Low, the CH1837A/7F/8A is On-Hook. The On-Hook state indicates to the CO that the CH1837A/7F/8A is ready to receive calls.

When the OFFHK input is TTL High, the CH1837A/7F/8A is Off-Hook. The Off-Hook state indicates to the CO that the CH1837A/7F/8A is either answering a call or preparing to place a call.

OFFHK Input: Active HIGH
 OFFHK active Current: 5mA

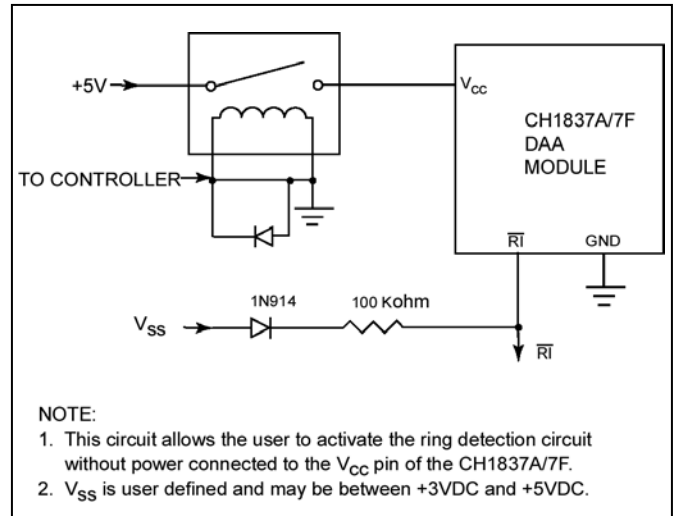

Figure 4. Low Power Ring Detection Circuit.

2-Wire to 4-Wire Hybrid Converter (CH1837A/F only). This circuit block performs two functions:

1. It applies the XMIT signal to the PSTN line, and
2. It subtracts the XMIT signal from the total signal present on the PSTN line thereby deriving the RCV signal.

The accuracy of the RCV signal derivation depends on how closely the impedance of the PSTN line matches an ideal 600 Ohms. Generally, a small amount of the XMIT signal will appear at RCV due to the non-ideal nature of the PSTN line impedance. The ratio of the applied XMIT signal to the received XMIT signal is called Trans-Hybrid Rejection, or Trans-Hybrid Loss.

PSTN Line Isolation and Surge/Peak Voltage Protection.

The Public Switched Telephone Network (PSTN) line isolation barrier circuitry provides isolation and the required surge and high voltage protection. This circuitry effectively isolates the user's equipment from both the PSTN line and the CO. The CH1837A/7F/8A has been designed to meet both FCC Part 68 (USA) and DOT CSA CS-03 Part I (Canada) isolation and surge requirements when circuited as indicated in Figure 5. Among the more critical parameters, the PSTN isolation barrier will provide at least 1500VAC RMS isolation and 2122V peak surge protection. The CH1837A/7F/8A is also UL1950 Edition 3 listed and meets CSA C222-950 test conditions when connected as indicated in Figure 5.

TRANSMIT SIGNALS

The CH1837A/7F/8A does not attenuate the transmit signal before it applies the signal across tip and ring. Therefore, a transmit signal of -9dBm applied to XMIT will comply with the FCC Part 68 requirement for data signals across Tip and Ring.

CH1837A/F. The user presents all outgoing transmit signals to the XMIT(-) pin with respect to GND for single ended operation or between XMIT(-) and XMIT (+) for differential operation. This signal must be AC coupled through a 0.1 μ F capacitor present on both the XMIT(-) and XMIT(+) pins as shown in Figure 3.

For single-ended operation, the outgoing analog signal is applied to the XMIT(-) pin with respect to GND. This signal must be AC coupled using a 0.1 μ F capacitor as shown in Figure 3. In single ended signal operation, the XMIT(+) pin must be connected to GND through a 0.1 μ F capacitor.

CH1838A. All incoming and outgoing signals are presented between T1 and T2. The user must provide an external hybrid conversion circuit and/or control the flow of the transmit and receive signals into/from the CH1838A.

RECEIVE SIGNALS

The incoming analog signal appears across TIP and RING. The CH1837A/7F/8A does not amplify the receive signal. Receive signals can vary from a maximum strength of -9dBm to below -50dBm.

CH1837A/F. The CH1837A/F derives the incoming signal and presents it at RCV with respect to GND. The user must AC couple RCV through a 0.1 μ F capacitor as indicated in Figure 3.

CH1838A. The CH1838A presents the incoming signal between T1 and T2. The user must provide an external hybrid conversion circuit and/or control the flow of the transmit and receive signals into/from the CH1838A.

Attenuation:	0.0dN
Input Impedance:	150K Ω
Typical Input Signal:	0dBm or 0.775Vrms with the Signal referenced to GND and AC coupled

UL RECOGNITION

To further protect the end product containing the CH1837A/7F/8A from field failures caused by large transients present on poor quality PSTN lines and to maintain UL recognition, an additional level of external

transient protection is required. Refer to Figure 5 for mandatory additional protection circuitry.

DESIGN CONSIDERATIONS

The CH1837A/7F/8A DAA includes circuitry that couples the modem signals to the PSTN line and provides the FCC required voltage isolation and surge protection when circuited per Figure 5 herein. Cermetek offers the following end product design guidelines as suggestions only. These guidelines are intended to facilitate the usage of Cermetek DAA modules and to assist the user with FCC certification of their end product.

1. Mount the DAA in the final assembly so that it is isolated from exposure to any hazardous voltages within the assembly. Adequate separation and restraint of cables and cords must be provided.
2. Connect to the PSTN line through a standard FCC approved RJ-11C jack or equivalent. For RJ-11, use the two center pins.
3. All PCB traces from the CH1837A/7F/8A TIP and RING pins must be at least 0.1 inch spacing from all other traces or other conducting material. The purpose for this spacing is to maintain 1500 VC isolation between the incoming PSTN line and the other traces. PSTN related PCB Traces should have a width of 0.020 inches or greater.
4. TIP and RING PCB traces should be as short as possible and should be oriented to prevent direct or induced coupling with other signals present on the PCB.
5. The CH1837A/7F/8A processes signals in the millivolt range. Even though the CH1837A/7F/8A is designed to handle noise in the power supply, steps should be taken to assure that the noise level does not exceed 50 mV peak-to-peak. Particular attention should be paid to both the power supply and the ground line PCB traces.
6. For data calls, FCC Part 68 rules require silence on the PSTN line for at least 2 seconds after a data call has been completed to allow central offices to exchange billing information. Further, Part 68 specifies that the transmit level must not exceed -9dBm.
7. For voice calls, the FCC rules require that the end product must meet the requirements of Part 68 for Out-of-Band Energy, and DTMF Transmit Levels.

HANDLING AND ASSEMBLY RECOMMENDATIONS

The CH1837A/7F/8A DAA Module contains static-sensitive components and should only be handled by personnel and in areas that are properly protected against static discharge. Industry standard ESD and EOS procedures and precautions should be observed when handling CH1837A/7F/8A products.

MOUNTING THE DAA

There are two mounting techniques recommended for physically connecting the CH1837A/7F/8A DAA to a PCB:

1. Direct soldering.
2. Sockets.

Direct Soldering. The CH1837A/7F/8A may be wave soldered onto a circuit card. All CH1837A/7F/8A products are hermetically sealed and will not be harmed by industry standard wave soldering processes.

To avoid the problems of flux contamination, hand soldering is preferred to wave soldering. When cleaning, use only demonized water.

Socketing. The socketing approach to mounting eliminates cleaning and desoldering concerns. When the socket is used, it must make a solid connection to all pins. Failure to do so will cause unreliable or intermittent operation.

When using sockets, steps should be taken to assure that the DAA module remains tightly seated in the socket after the end product is shipped. It is recommended that some type of mechanical restraint be provided to keep the CH1837A/7F/8A seated to avoid any possibility that the CH1837A/7F/8A works loose during shipment. See Application Note # 130, Summary of Recommended Suppliers for a list of recommended socket manufacturers.

FCC (USA) REGISTRATION

Because the CH1837A/7F/8A already meets the FCC requirements for Part 68 registration for High Voltage Isolation and Surge Protection when circuited per the requirements of Figure 5 herein, certification of the end product containing the CH1837A/7F/8A DAA is normally quite simple. The process involves testing the end system for compliance and submitting the test data to the FCC for review.

Typically, independent FCC approved testing labs are contracted to perform the required tests on the end product and to submit the required paperwork to the FCC. If desired, Cermetek can assist with the Registration activity.

DOT (CANADA) REGISTRATION

The CH1837A/7F/8A DAA meets or exceeds the hazardous voltage, surge and leakage requirements of the FCC when circuited per the requirements of Figure 5 herein. Although the FCC and DOT requirements are virtually identical, it is recommended that for applications that connect to Canadian PSTN lines, a Canadian test house/consultant be retained to ensure compliance of the end product.

Table 1. CH1837A/F Pin Description.

PIN	I/O	CH1837A/F	FUNCTION
1	I/O	TIP	TIP. Direct PSTN line connection.
2	I/O	RING	RING. Direct PSTN line connection.
3	I	OFFHK	OFF-HOOK. Used to toggle CH1837A/F product between On-Hook and Off-Hook. When set LOW, CH1837A/F is On-Hook. When set HIGH, CH1837A/F is set Off-Hook to answer or place a call. See Note 1.
4	O	RI	RING INDICATION. Indicates the presence of a ring signal between TIP and RING pins. RI output is a square wave coincident with the incoming AC ring signal. The RI square wave output can be conditioned to produce an envelope of the incoming AC ring signal by using the circuit in Figure 4. See Notes 2 and 3.
5	O	RCV	RECEIVE. Audio output signal with respect to GND. AC couple RCV through 0.1 μ F capacitor to eliminate any DC offset.
6	I	XMIT(-)	TRANSMIT(+). Audio input signal. AC couple through 0.1 μ F capacitor. The CH1837A/F can be used in differential mode with XMIT(+), or in single ended mode with respect to GND.
7	I	V _{CC}	POWER SUPPLY. +5V \pm 5%. Supply line noise should be less than 50mV peak to peak.
8	I	XMIT(+)	TRANSMIT(-). Audio input signal for CH1837A/F when used in differential mode only. Connect to GND through 0.1 μ F capacity when CH1837A/F used in single ended input via PIN 8.
9	I	GND	GROUND. Supply line noise should be less than 50mV peak to peak.

Note:

1. When answering incoming calls in response to a ring indication on RI, internal degradation may occur if OFFHK is set HIGH before RI returns to its HIGH state.
2. For CH1837A, the RI output is 2X the frequency of the incoming ring signal.
3. For CH1837F, the RI output is 1X the frequency of the incoming ring signal.

Table 2. CH1838A Pin Description.

PIN	I/O	CH1838A	FUNCTION
1	I/O	TIP	TIP. Direct PSTN line connection.
2	I/O	RING	RING. Direct PSTN line connection.
3	I	OFFHK	OFF-HOOK. Used to toggle CH18378 product between On-Hook and Off-Hook. When set LOW, CH1838 is On-Hook. When set HIGH, CH1838 is set Off-Hook to answer or place a call. See Note 1.
4	O	RI	RING INDICATION. Indicates the presence of a ring signal between TIP and RING pins. RI output is a square wave coincident with the incoming AC ring signal. The RI square wave output can be conditioned to produce an envelope of the incoming AC ring signal by using the circuit in Figure 4. The RI output is 2X the frequency of the incoming ring signal.
5	I/O	T1	RECEIVE. Audio input and output signal with respect to T2.
6	N/C	N/C	AUDIO INPUT/OUTPUT. Internally not connected. Either let float or connect to GND.
7	I	V _{CC}	POWER SUPPLY. +5V \pm 5%. Supply line noise should be less than 50mV peak to peak.
8	I/O	T2	AUDIO INPUT/OUTPUT. Audio input and output signal with respect to T1.
9	I	GND	GROUND. Supply line noise should be less than 50mV peak to peak.

Note:

1. When answering incoming calls in response to a ring indicator on RI, internal degradation may occur if OFFHK is set HIGH before RI returns to its HIGH state.

Table 3. CH1837A/7F/8A Electrical Specifications.

Parameter	Conditions	Min.	Typ.	Max.	Units
Logic Input HIGH Input LOW Input Leakage HIGH Input Leakage LOW Output HIGH Output LOW	IOH=0.05mA IOL=2.0mA	2.4		0.4 500 -500	V V μA μA V V
Isolation Protection Between TIP and RING	CH1837A/7F/8A	1500			VAC RMS
Surge Protection Between TIP and RING	CH1837A/7F/8A	2212			V _{Peak}
Transmission Insertion Loss	Attenuation between the transmitter input PSTN line at 1.8kHz with 600ohms termination (flat from 300-4kHz)	-0.8	0	+0.8	dB
Frequency Response (Ref=1800Hz Transit)	200-4kHz	-0.3		+0.3	dBm
Distortion Noise-Transmit	-10dBm transmit power (600Hz)			-82	dBm
Receive Gain	Gain between PSTN line and receive output at 1800Hz with 600 ohm resistive termination (flat from 300-4kHz)	-0.5	0	+0.5	dB
Receive Frequency Response (Ref = 1800Hz Receive)	200-4kHz	-0.3		+0.3	dBm
Receive 2 nd /3 rd /4 th Harmonic Distortion	-10dB at TIP and RING			-82	dBm
Noise-Receive	400Hz-4kHz		-82		dBm
PSTN Line Input Impedance	At 1800Hz	550	600	650	Ohm
On-Hook Impedance		10	20		mOhms
Loop Current	48VDC from TIP to RING.	20		100	mA
Longitudinal Balance	OH=0 (On-Hook) OH=1 (Off-Hook)	66 66			dBm dbm
Return Loss (Zref=600ohm, 2.16μF)	1kHz	25			dBm
Trans-Hybrid Loss	Attenuation between the transmitter input and receiver output at 1kHz with 600ohm complex termination	22	25		dB
Transmit Input Impedance	At 1800Hz	120	150	200	kOhm
Receive Output Impedance	At 1800Hz		10	100	Ohms
Ring Select Sensitivity	AC voltage between TIP and RING	38			V _{rms}
Hook Switch Control Current	Drive capable of sourcing current	4			mA
Weight			20		gm
Supply Current	V _{CC} =+5VDC±5%, Off-Hook V _{CC} =+5VDC±5%, On-Hook		5	8	mA mA
Ringer Equivalence	Type A		0.2A		REN

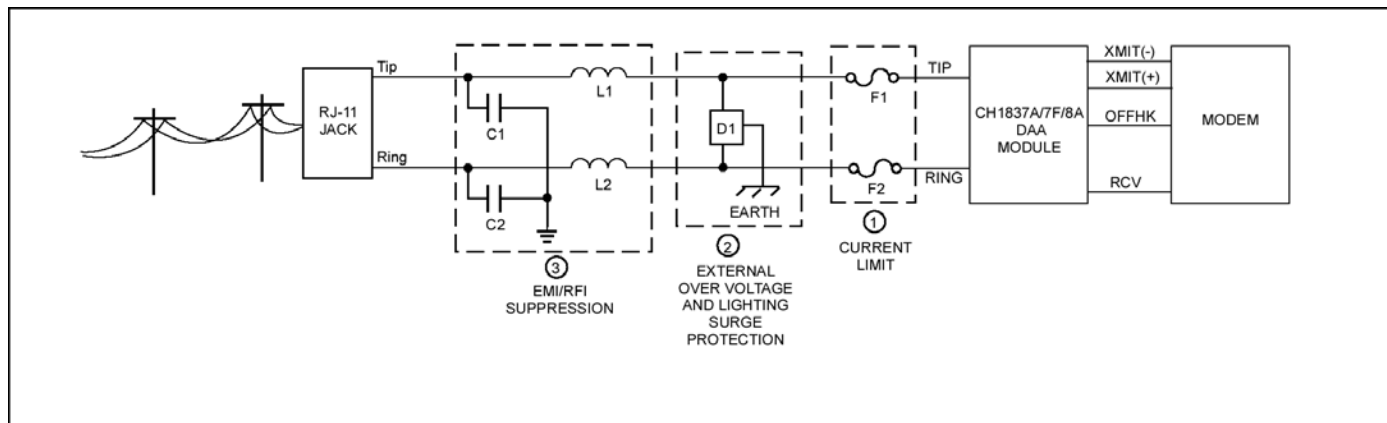

Figure 5. PSTN Line Interface.

1. Currently Limiting PSTN Protection Line Device.

Currently limiting devices are mandatory to meet UL safety standards. For FCC Part 68 approval, the current limiting components identified as F1 and F2 in dashed Box #1 must also survive FCC Part 68 surge testing. Refer to Cermetek Application Note #126, Supplemental PSTN Line Protection, for more details. Refer to Application Note # 130, Summary of Recommend Suppliers, for a list of suppliers and associated part numbers.

- A. A Polyfuse (rated at 0.15 amps) is preferred because it resets automatically upon removal of the current flow. Non-resettable devices are also acceptable. Refer to Application Note #130 for a complete list of recommended vendors and associated part numbers.
- B. Resistors (10Ω carbon film or 1/8 watt minimum) may be used in Canada, as Canada has no requirements that PSTN equipment be operational after a Type B surge test.
- C. Although CSA CS-03 Part 1 (Canada) follows the requirements of FCC Part 68 (USA), Cermetek recommends contacting DOT (Canada) and/or a certified independent lab to verify compliance. For Canada, use either 10Ω resistors (carbon film or SMD parts 1/8 watt minimum) as described in paragraph B above.

2. Over Voltage and Lightning Protection.

- A. The required UL1950 and FCC Part 68 surge protection (identified as D1 in dashed Box 2) must be supplied externally. The purchaser must include some form of surge protection as described herein to obtain FCC Part 68

approval and to maintain UL1950 Edition 3 listing.

- B. In most environments, 2 terminal surge suppressors are adequate. For severe environments, use an external 3 terminal device (as indicated in Figure 5) with an earth ground.

3. EMI/RFI Suppression.

Additional suppression, if required, may be added as described below in Sections 3A-3B without adversely affecting FCC Part 68 approval or UL1950 listing.

- A. To provide adequate EMI/RFI suppression, the capacitor/inductor network contained in dashed Box #3 should be located as close to the RJ11 Jack as possible. Further, this network should be provided with an excellent ground path to the chassis.
- B. Capacitors C1 and C2 should not exceed 0.005μf. They must have a rating of 1.5KV and typically are 0.001μf ± 20%. Inductors L1 and L2 may be either individual inductors or a dual inductor. Refer to Application Note #130 for a complete list of recommended vendors and associated part numbers. For UL applications, choose capacitors and inductors that are UL 1950 listed. The actual values of the components used may vary depending on the end product design.

Table 4. Summary CH1837A/7F/8A Product Features.

Model	Summary of Features	Operating Temperature
CH1837A	33.6kbps DAA, 2-to-4 Wire Conversion, FCC Part 68 Compliant, UL 1950 Edition 3 Listed. RI is 2X the incoming ring frequency.	0°C to +70°C
CH1837F	33.6kbps DAA, 2-to-4 Wire Conversion, FCC Part 68 Compliant, UL 1950 Edition 3 Listed. RI is 1X the incoming ring frequency.	0°C to +70°C
CH1838A	33.6kbps DAA, FCC Part 68 Compliant, UL 1950 Edition 3 Listed Special Order Option to Standard CH1837A/F product.	0°C to +70°C

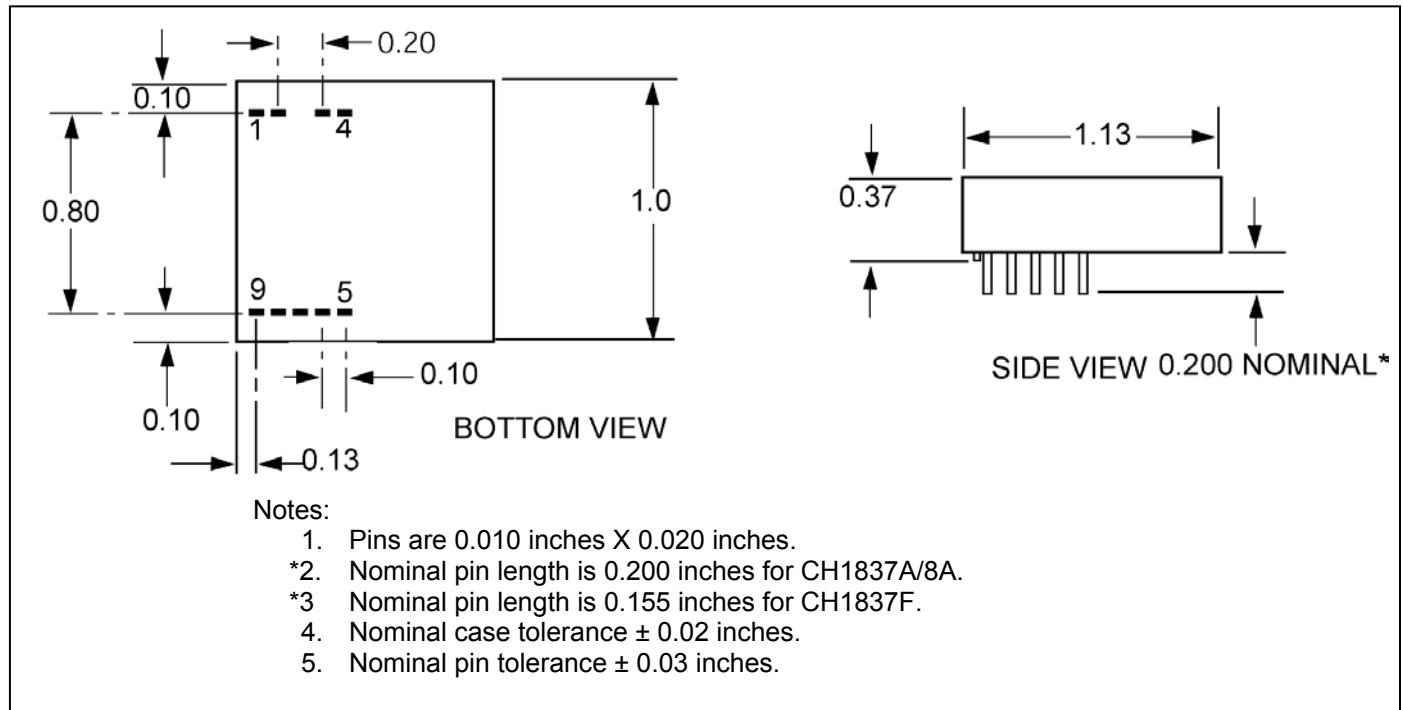

Figure 6. Physical Dimensions.

Cermetek reserves the right to make changes in specifications at any time and without notice. The information furnished by Cermetek in this publication is believed to be accurate and reliable. However, Cermetek assumes no responsibility for its use, or for any infringements of patents or other rights of third parties resulting from its use. No license is granted under any patents or patent rights of Cermetek.

Printed in U.S.A

