

Features

- Universal serial bus (USB) integration
 - USB 3.0 and USB 2.0 peripherals compliant with USB 3.0 specification 1.0
 - 5-Gbps USB 3.0 PHY compliant with PIPE 3.0
 - High-speed On-The-Go (HS-OTG) host and peripheral compliant with OTG Supplement Version 2.0
 - Thirty-two physical endpoints
 - Support for battery charging Spec 1.1 and accessory charger adaptor (ACA) detection
- General Programmable Interface (GPIF[™] II)
 - Programmable 100-MHz GPIF II enables connectivity to a wide range of external devices
 - 8-, 16-, and 32-bit data bus
 - As many as 16 configurable control signals
- Fully accessible 32-bit CPU
 - ARM926EJ core with 200-MHz operation
 - 512-KB or 256-KB embedded SRAM
- Additional connectivity to the following peripherals
 - I²C master controller at 1 MHz
 - I²S master (transmitter only) at sampling frequencies of 32 kHz, 44.1 kHz, and 48 kHz
 - UART support of up to 4 Mbps
 - SPI master at 33 MHz
- Selectable clock input frequencies
 - 19.2, 26, 38.4, and 52 MHz
 - 19.2-MHz crystal input support
- Ultra low-power in core power-down mode
 - Less than 60 μ A with V_{BATT} on and 20 μ A with V_{BATT} off
- Independent power domains for core and I/O
 - Core operation at 1.2 V
 - I²S, UART, and SPI operation at 1.8 to 3.3 V
 - I²C operation at 1.2 V
- Package option
 - 121-ball, 10- x 10-mm, 0.8-mm pitch Pb-free ball grid array (BGA)
 - 131-ball, 4.7- x 5.1-mm, 0.4-mm pitch wafer-level chip scale package (WLCSP)
- EZ-USB[®] software and development kit (DVK) for easy code development

Applications

- Digital video camcorders
- Digital still cameras
- Printers
- Scanners
- Video capture cards
- Test and measurement equipment
- Surveillance cameras
- Personal navigation devices
- Medical imaging devices
- Video IP phones
- Portable media players
- Industrial cameras

Logic Block Diagram

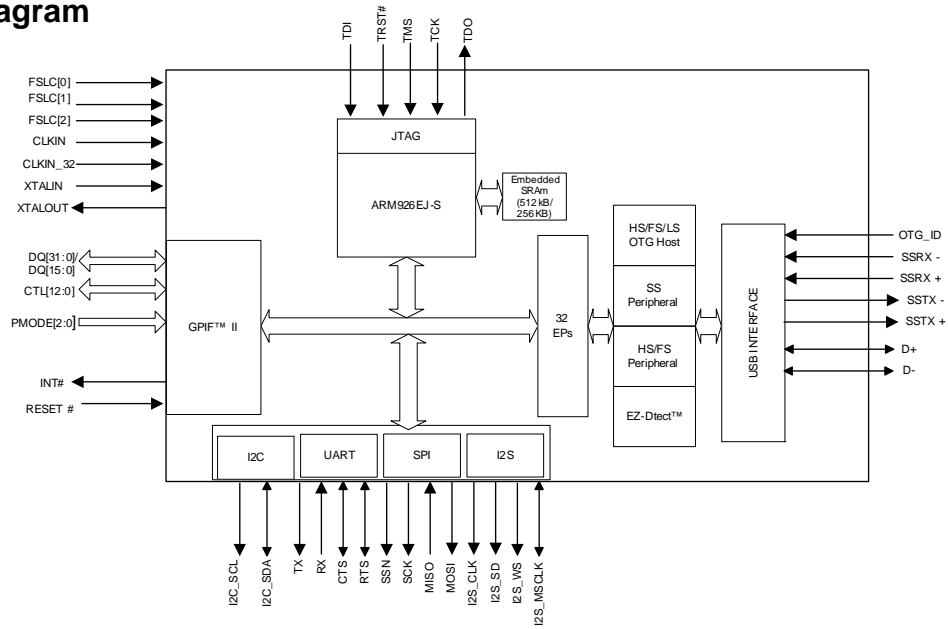

Contents

Functional Overview	4	Pin Description	15
Application Examples	4	Absolute Maximum Ratings	22
USB Interface	5	Operating Conditions	22
OTG	5	DC Specifications	22
ReNumeration	6	AC Timing Parameters	24
EZ-Dtect	6	GPIF II Timing	24
VBUS Overvoltage Protection	6	Slave FIFO Interface	27
Carkit UART Mode	6	Synchronous Slave FIFO	
GPIF II	7	Write Sequence Description	28
CPU	7	Asynchronous Slave FIFO	
JTAG Interface	8	Read Sequence Description	29
Other Interfaces	8	Asynchronous Slave FIFO	
UART Interface	8	Write Sequence Description	30
I2C Interface	8	Serial Peripherals Timing	33
I2S Interface	8	Reset Sequence	38
SPI Interface	8	Package Diagram	39
Boot Options	9	Ordering Information	41
Reset	9	Ordering Code Definitions	41
Hard Reset	9	Acronyms	42
Soft Reset	9	Document Conventions	42
Clocking	9	Units of Measure	42
32-kHz Watchdog Timer Clock Input	10	Document History Page	43
Power	10	Sales, Solutions, and Legal Information	45
Power Modes	10	Worldwide Sales and Design Support	45
Configuration Options	13	Products	45
Digital I/Os	13	PSoC Solutions	45
GPIOs	13		
System-level ESD	13		
Pin Configurations	13		

Functional Overview

Cypress's EZ-USB FX3 is the next-generation USB 3.0 peripheral controller, providing integrated and flexible features.

FX3 has a fully configurable, parallel, general programmable interface called GPIF II, which can connect to any processor, ASIC, or FPGA. GPIF II is an enhanced version of the GPIF in FX2LP, Cypress's flagship USB 2.0 product. It provides easy and glueless connectivity to popular interfaces, such as asynchronous SRAM, asynchronous and synchronous address data multiplexed interfaces, and parallel ATA.

FX3 has integrated the USB 3.0 and USB 2.0 physical layers (PHYs) along with a 32-bit ARM926EJ-S microprocessor for powerful data processing and for building custom applications. It implements an architecture that enables 375-Mbps data transfer from GPIF II to the USB interface.

An integrated USB 2.0 OTG controller enables applications in which FX3 may serve dual roles; for example, EZ-USB FX3 may function as an OTG Host to MSC as well as HID-class devices.

FX3 contains 512 KB or 256 KB of on-chip SRAM (see [Ordering Information](#) on page 41) for code and data. EZ-USB FX3 also provides interfaces to connect to serial peripherals such as UART, SPI, I²C, and I²S.

FX3 comes with application development tools. The software development kit comes with application examples for accelerating time to market.

FX3 complies with the USB 3.0 v1.0 specification and is also backward compatible with USB 2.0. It also complies with the Battery Charging Specification v1.1 and USB 2.0 OTG Specification v2.0.

Application Examples

In a typical application (see [Figure 1](#)), FX3 functions as a coprocessor and connects to an external processor, which manages system-level functions. [Figure 2](#) shows a typical application diagram when FX3 functions as the main processor.

Figure 1. EZ-USB FX3 as a Coprocessor

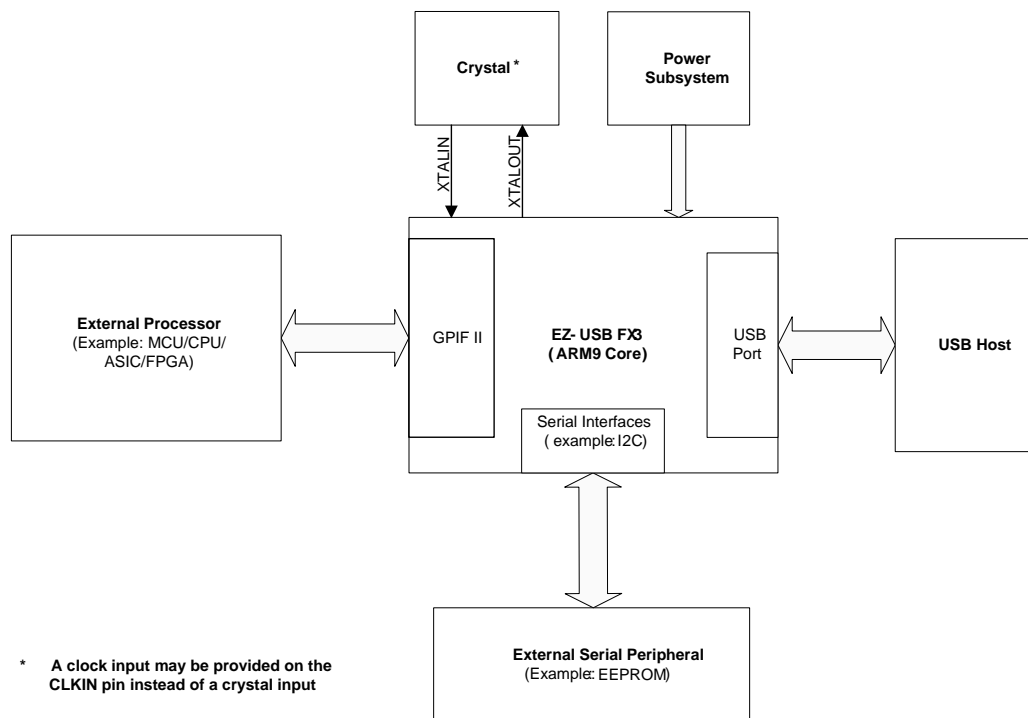

Note

1. Assuming that GPIF II is configured for a 32-bit data bus (available with certain part numbers; see [Ordering Information](#) on page 41), synchronous interface operating at 100 MHz. This number also includes protocol overheads.

Figure 2. EZ-USB FX3 as Main Processor

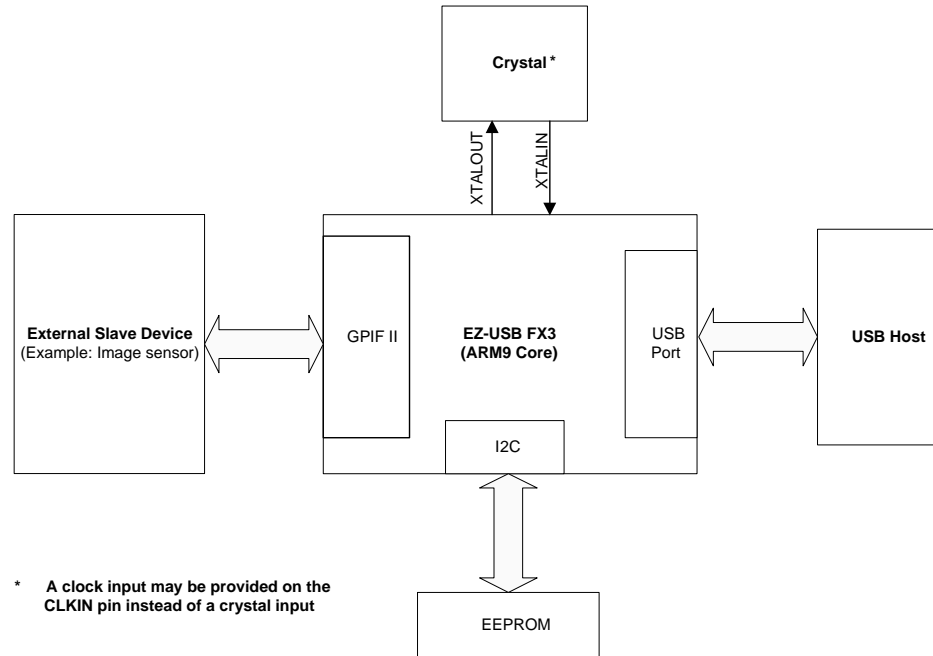

USB Interface

FX3 complies with the following specifications and supports the following features:

- Supports USB peripheral functionality compliant with USB 3.0 Specification Revision 1.0 and is also backward compatible with the USB 2.0 Specification.
- Complies with OTG Supplement Revision 2.0. It supports High-Speed, Full-Speed, and Low-Speed OTG dual-role device capability. As a peripheral, FX3 is capable of SuperSpeed, High-Speed, and Full-Speed. As a host, it is capable of High-Speed, Full-Speed, and Low-Speed.
- Supports CarKit Pass-Through UART functionality on USB D+/D- lines based on the CEA-936A specification.
- Supports up to 16 IN and 16 OUT endpoints.
- Supports the USB 3.0 Streams feature. It also supports USB Attached SCSI (UAS) device-class to optimize mass-storage access performance.
- As a USB peripheral, FX3 supports UAS, USB Video Class (UVC), Mass Storage Class (MSC), and Media Transfer Protocol (MTP) USB peripheral classes. As a USB peripheral, all other device classes are supported only in pass-through mode when handled entirely by a host processor external to the device.
- As an OTG host, FX3 supports MSC and HID device classes.

Note When the USB port is not in use, disable the PHY and transceiver to save power.

Figure 3. USB Interface Signals

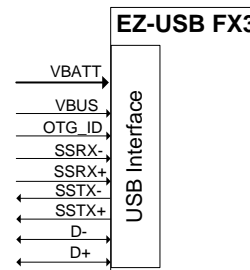

OTG

FX3 is compliant with the OTG Specification Revision 2.0. In OTG mode, FX3 supports both A and B device modes and supports Control, Interrupt, Bulk, and Isochronous data transfers.

FX3 requires an external charge pump (either standalone or integrated into a PMIC) to power VBUS in the OTG A-device mode.

The Target Peripheral List for OTG host implementation consists of MSC- and HID-class devices.

FX3 does not support Attach Detection Protocol (ADP).

OTG Connectivity

In OTG mode, FX3 can be configured to be an A, B, or dual-role device. It can connect to the following:

- ACA device
- Targeted USB peripheral
- SRP-capable USB peripheral
- HNP-capable USB peripheral
- OTG host
- HNP-capable host
- OTG device

ReNumeration

Because of FX3’s soft configuration, one chip can take on the identities of multiple distinct USB devices.

When first plugged into USB, FX3 enumerates automatically with the Cypress Vendor ID (0x04B4) and downloads firmware and USB descriptors over the USB interface. The downloaded firmware executes an electrical disconnect and connect. FX3 enumerates again, this time as a device defined by the downloaded information. This patented two-step process, called ReNumeration, happens instantly when the device is plugged in.

EZ-Dtect

FX3 supports USB Charger and accessory detection (EZ-Dtect). The charger detection mechanism complies with the Battery Charging Specification Revision 1.1. In addition to supporting this version of the specification, FX3 also provides hardware support to detect the resistance values on the ID pin.

FX3 can detect the following resistance ranges:

- Less than 10 Ω
- Less than 1 kΩ
- 65 kΩ to 72 kΩ
- 35 kΩ to 39 kΩ
- 99.96 kΩ to 104.4 kΩ (102 kΩ ± 2%)
- 119 kΩ to 132 kΩ
- Higher than 220 kΩ
- 431.2 kΩ to 448.8 kΩ (440 kΩ ± 2%)

FX3’s charger detects a dedicated wall charger, Host/Hub charger, and Host/Hub.

VBUS Overvoltage Protection

The maximum input voltage on FX3’s VBUS pin is 6 V. A charger can supply up to 9 V on VBUS. In this case, an external overvoltage protection (OVP) device is required to protect FX3 from damage on VBUS. Figure 4 shows the system application diagram with an OVP device connected on VBUS. Refer to Table 7 for the operating range of VBUS and VBATT.

Figure 4. System Diagram with OVP Device For VBUS

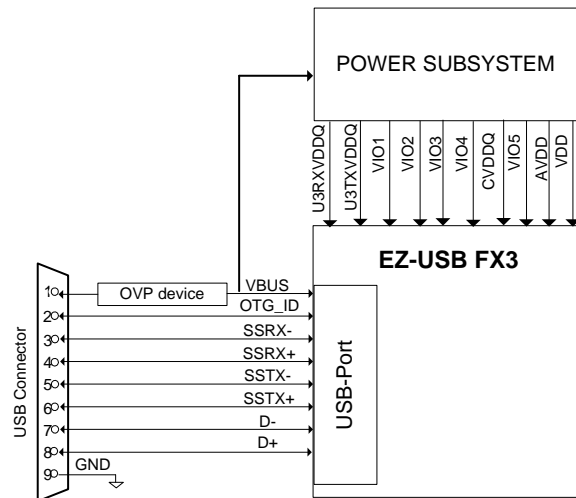

Carkit UART Mode

The USB interface supports the Carkit UART mode (UART over D+/D-) for non-USB serial data transfer. This mode is based on the CEA-936A specification.

In the Carkit UART mode, the output signaling voltage is 3.3 V. When configured for the Carkit UART mode, TXD of UART (output) is mapped to the D- line, and RXD of UART (input) is mapped to the D+ line.

In the Carkit UART mode, FX3 disables the USB transceiver and D+ and D- pins serve as pass-through pins to connect to the UART of the host processor. The Carkit UART signals may be routed to the GPIF II interface or to GPIO[48] and GPIO[49], as shown in Figure 5 on page 7.

In this mode, FX3 supports a rate of up to 9600 bps.

Figure 5. Carkit UART Pass-through Block Diagram

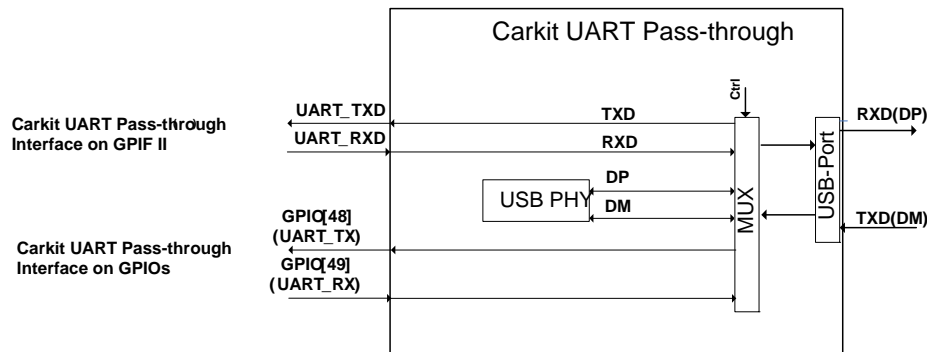

GPIF II

The high-performance GPIF II interface enables functionality similar to, but more advanced than, FX2LP's GPIF and Slave FIFO interfaces.

The GPIF II is a programmable state machine that enables a flexible interface that may function either as a master or slave in industry-standard or proprietary interfaces. Both parallel and serial interfaces may be implemented with GPIF II.

Here are a list of GPIF II features:

- Functions as master or slave
- Provides 256 firmware programmable states
- Supports 8-bit, 16-bit, and 32-bit parallel data bus
- Enables interface frequencies up to 100 MHz
- Supports 14 configurable control pins when a 32-bit data bus is used. All control pins can be either input/output or bidirectional.
- Supports 16 configurable control pins when a 16/8 data bus is used. All control pins can be either input/output or bi-directional.

GPIF II state transitions are based on control input signals. The control output signals are driven as a result of the GPIF II state transitions. The INT# output signal can be controlled by GPIF II. Refer to the GPIFII Designer tool. The GPIF II state machine's behavior is defined by a GPIF II descriptor. The GPIF II descriptor is designed such that the required interface specifications are met. 8 kB of memory (separate from the 512 kB of embedded SRAM) is dedicated to the GPIF II waveform where the GPIF II descriptor is stored in a specific format.

Cypress's GPIFII Designer Tool enables fast development of GPIF II descriptors and includes examples for common interfaces.

Example implementations of GPIF II are the asynchronous slave FIFO and synchronous slave FIFO interfaces.

Slave FIFO interface

The Slave FIFO interface signals are shown in Figure 6. This interface allows an external processor to directly access up to four buffers internal to FX3. Further details of the Slave FIFO interface are described on page 27.

Note Access to all 32 buffers is also supported over the slave FIFO interface. For details, contact Cypress Applications Support.

Figure 6. Slave FIFO Interface

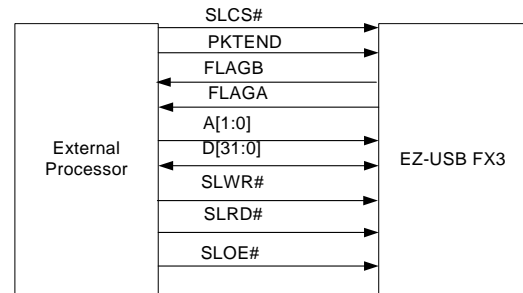

Note: Multiple Flags may be configured.

CPU

FX3 has an on-chip 32-bit, 200-MHz ARM926EJ-S core CPU. The core has direct access to 16 kB of Instruction Tightly Coupled Memory (TCM) and 8 kB of Data TCM. The ARM926EJ-S core provides a JTAG interface for firmware debugging.

FX3 offers the following advantages:

- Integrates 512 KB of embedded SRAM for code and data and 8 kB of Instruction cache and Data cache.
- Implements efficient and flexible DMA connectivity between the various peripherals (such as, USB, GPIF II, I²S, SPI, UART), requiring firmware only to configure data accesses between peripherals, which are then managed by the DMA fabric.
- Allows easy application development on industry-standard development tools for ARM926EJ-S.

Examples of the FX3 firmware are available with the Cypress EZ-USB FX3 Development Kit. Software APIs that can be ported to an external processor are available with the Cypress EZ-USB FX3 Software Development Kit.

JTAG Interface

FX3's JTAG interface has a standard five-pin interface to connect to a JTAG debugger in order to debug firmware through the CPU-core's on-chip-debug circuitry.

Industry-standard debugging tools for the ARM926EJ-S core can be used for the FX3 application development.

Other Interfaces

FX3 supports the following serial peripherals:

- UART
- I²C
- I²S
- SPI

The SPI, UART, and I²S interfaces are multiplexed on the serial peripheral port.

The [CYUSB3012 and CYUSB3014 Pin List \(GPIF II with 32-bit Data Bus Width\)](#) on page 15 shows details of how these interfaces are multiplexed. Note that when GPIF II is configured for a 32-bit data bus width (CYUSB3012 and CYUSB3014), only the UART interface is available on GPIO[53] to GPIO[56].

UART Interface

The UART interface of FX3 supports full-duplex communication. It includes the signals noted in [Table 1](#).

Table 1. UART Interface Signals

Signal	Description
TX	Output signal
RX	Input signal
CTS	Flow control
RTS	Flow control

The UART is capable of generating a range of baud rates, from 300 bps to 4608 Kbps, selectable by the firmware. If flow control is enabled, then FX3's UART only transmits data when the CTS input is asserted. In addition to this, FX3's UART asserts the RTS output signal, when it is ready to receive data.

I²C Interface

FX3's I²C interface is compatible with the I²C Bus Specification Revision 3. This I²C interface is capable of operating only as I²C master; therefore, it may be used to communicate with other I²C slave devices. For example, FX3 may boot from an EEPROM connected to the I²C interface, as a selectable boot option.

FX3's I²C Master Controller also supports multi-master mode functionality.

The power supply for the I²C interface is VIO5, which is a separate power domain from the other serial peripherals. This gives the I²C interface the flexibility to operate at a different voltage than the other serial interfaces.

The I²C controller supports bus frequencies of 100 kHz, 400 kHz, and 1 MHz. When VIO5 is 1.2 V, the maximum operating frequency supported is 100 kHz. When VIO5 is 1.8 V, 2.5 V, or 3.3 V, the operating frequencies supported are 400 kHz and 1 MHz. The I²C controller supports the clock-stretching feature to enable slower devices to exercise flow control.

The I²C interface's SCL and SDA signals require external pull-up resistors. The pull-up resistors must be connected to VIO5.

I²S Interface

FX3 has an I²S port to support external audio codec devices. FX3 functions as I²S Master as transmitter only. The I²S interface consists of four signals: clock line (I2S_CLK), serial data line (I2S_SD), word select line (I2S_WS), and master system clock (I2S_MCLK). FX3 can generate the system clock as an output on I2S_MCLK or accept an external system clock input on I2S_MCLK.

The sampling frequencies supported by the I²S interface are 32 kHz, 44.1 kHz, and 48 kHz.

SPI Interface

FX3 supports an SPI Master interface on the Serial Peripherals port. The maximum operation frequency is 33 MHz.

The SPI controller supports four modes of SPI communication (see [SPI Timing Specification](#) on page 36 for details on the modes) with the Start-Stop clock. This controller is a single-master controller with a single automated SSN control. It supports transaction sizes ranging from 4 bits to 32 bits.

Boot Options

FX3 can load boot images from various sources, selected by the configuration of the PMODE pins. Following are the FX3 boot options:

- Boot from USB
- Boot from I²C
- Boot from SPI (SPI devices supported are M25P16 (16 Mbit), M25P80 (8 Mbit), and M25P40 (4 Mbit)) or their equivalents
- Boot from GPIF II ASync ADMux mode
- Boot from GPIF II Sync ADMux mode
- Boot from GPIF II ASync SRAM mode

Table 2. FX3 Booting Options

PMODE[2:0] ^[2]	Boot From
F00	Sync ADMux (16-bit)
F01	ASync ADMux (16-bit)
F11	USB boot
F0F	ASync SRAM (16-bit)
F1F	I ² C, On Failure, USB Boot is Enabled
1FF	I ² C only
0F1	SPI, On Failure, USB Boot is Enabled

Reset

Hard Reset

A hard reset is initiated by asserting the Reset# pin on FX3. The specific reset sequence and timing requirements are detailed in [Figure 19](#) on page 38 and [Table 16](#) on page 38. All I/Os are tristated during a hard reset.

Soft Reset

In a soft reset, the processor sets the appropriate bits in the PP_INIT control register. There are two types of Soft Reset:

- CPU Reset – The CPU Program Counter is reset. Firmware does not need to be reloaded following a CPU Reset.
- Whole Device Reset – This reset is identical to Hard Reset.
- The firmware must be reloaded following a Whole Device Reset.

Clocking

FX3 allows either a crystal to be connected between the XTALIN and XTALOUT pins or an external clock to be connected at the CLKIN pin. The XTALIN, XTALOUT, CLKIN, and CLKIN_32 pins can be left unconnected if they are not used.

Crystal frequency supported is 19.2 MHz, while the external clock frequencies supported are 19.2, 26, 38.4, and 52 MHz.

FX3 has an on-chip oscillator circuit that uses an external 19.2-MHz (±100 ppm) crystal (when the crystal option is used). An appropriate load capacitance is required with a crystal. Refer to the specification of the crystal used to determine the appropriate load capacitance. The FSLC[2:0] pins must be configured appropriately to select the crystal- or clock-frequency option. The configuration options are shown in [Table 3](#).

Clock inputs to FX3 must meet the phase noise and jitter requirements specified in [Table 4](#) on page 10.

The input clock frequency is independent of the clock and data rate of the FX3 core or any of the device interfaces (including P-Port and S-Port). The internal PLL applies the appropriate clock multiply option depending on the input frequency.

Table 3. Crystal/Clock Frequency Selection

FSLC[2]	FSLC[1]	FSLC[0]	Crystal/Clock Frequency
0	0	0	19.2-MHz crystal
1	0	0	19.2-MHz input CLK
1	0	1	26-MHz input CLK
1	1	0	38.4-MHz input CLK
1	1	1	52-MHz input CLK

Note

2. F indicates Floating.

Table 4. FX3 Input Clock Specifications

Parameter	Description	Specification		Units
		Min	Max	
Phase noise	100-Hz offset	–	–75	dB
	1- kHz offset	–	–104	dB
	10-kHz offset	–	–120	dB
	100-kHz offset	–	–128	dB
	1-MHz offset	–	–130	dB
Maximum frequency deviation		–	150	ppm
Duty cycle		30	70	%
Overshoot		–	3	%
Undershoot		–	–3	%
Rise time/fall time		–	3	ns

32-kHz Watchdog Timer Clock Input

FX3 includes a watchdog timer. The watchdog timer can be used to interrupt the ARM926EJ-S core, automatically wake up the FX3 in Standby mode, and reset the ARM926EJ-S core. The watchdog timer runs a 32-kHz clock, which may be optionally supplied from an external source on a dedicated FX3 pin.

The firmware can disable the watchdog timer.

Requirements for the optional 32-kHz clock input are listed in [Table 5](#).

Table 5. 32-kHz Clock Input Requirements

Parameter	Min	Max	Units
Duty cycle	40	60	%
Frequency deviation	–	±200	ppm
Rise time/fall time	–	200	ns

Power

FX3 has the following power supply domains:

■ **IO_VDDQ**: This is a group of independent supply domains for digital I/Os. The voltage level on these supplies is 1.8 V to 3.3 V. FX3 provides six independent supply domains for digital I/Os listed as follows (see [Table 7](#) for details on each of the power domain signals):

- VIO1: GPIF II I/O
- VIO2: IO2
- VIO3: IO3
- VIO4: UART-/SPI/I²S
- VIO5: I²C and JTAG (supports 1.2 V to 3.3 V)

□ CVDDQ: Clock

□ **V_{DD}**: This is the supply voltage for the logic core. The nominal supply-voltage level is 1.2 V. This supplies the core logic circuits. The same supply must also be used for the following:

- AVDD: This is the 1.2-V supply for the PLL, crystal oscillator, and other core analog circuits
- U3TXVDDQ/U3RXVDDQ: These are the 1.2-V supply voltages for the USB 3.0 interface.

■ **VBATT/VBUS**: This is the 3.2-V to 6-V battery power supply for the USB I/O and analog circuits. This supply powers the USB transceiver through FX3's internal voltage regulator. VBATT is internally regulated to 3.3 V.

Power Modes

FX3 supports the following power modes:

■ **Normal mode**: This is the full-functional operating mode. The internal CPU clock and the internal PLLs are enabled in this mode.

- Normal operating power consumption does not exceed the sum of I_{CC} Core max and I_{CC} USB max (see [Table 7](#) for current consumption specifications).
- The I/O power supplies VIO2, VIO3, VIO4, and VIO5 can be turned off when the corresponding interface is not in use. VIO1 cannot be turned off at any time if the GPIF II interface is used in the application.

■ **Low-power modes** (see [Table 6](#) on page 11):

- Suspend mode with USB 3.0 PHY enabled (L1)
- Suspend mode with USB 3.0 PHY disabled (L2)
- Standby mode (L3)
- Core power-down mode (L4)

Table 6. Entry and Exit Methods for Low-Power Modes

Low-Power Mode	Characteristics	Methods of Entry	Methods of Exit
Suspend Mode with USB 3.0 PHY Enabled (L1)	<ul style="list-style-type: none"> ■ The power consumption in this mode does not exceed ISB₁ ■ USB 3.0 PHY is enabled and is in U3 mode (one of the suspend modes defined by the USB 3.0 specification). This one block alone is operational with its internal clock while all other clocks are shut down ■ All I/Os maintain their previous state ■ Power supply for the wakeup source and core power must be retained. All other power domains can be turned on/off individually ■ The states of the configuration registers, buffer memory, and all internal RAM are maintained ■ All transactions must be completed before FX3 enters Suspend mode (state of outstanding transactions are not preserved) ■ The firmware resumes operation from where it was suspended (except when woken up by RESET# assertion) because the program counter does not reset 	<ul style="list-style-type: none"> ■ Firmware executing on ARM926EJ-S core can put FX3 into suspend mode. For example, on USB suspend condition, firmware may decide to put FX3 into suspend mode ■ External Processor, through the use of mailbox registers, can put FX3 into suspend mode 	<ul style="list-style-type: none"> ■ D+ transitioning to low or high ■ D- transitioning to low or high ■ Impedance change on OTG_ID pin ■ Resume condition on SSRX± ■ Detection of VBUS ■ Level detect on UART_CTS (programmable polarity) ■ GPIF II interface assertion of CTL[0] ■ Assertion of RESET#
Suspend Mode with USB 3.0 PHY Disabled (L2)	<ul style="list-style-type: none"> ■ The power consumption in this mode does not exceed ISB₂ ■ USB 3.0 PHY is disabled and the USB interface is in suspend mode ■ The clocks are shut off. The PLLs are disabled ■ All I/Os maintain their previous state ■ USB interface maintains the previous state ■ Power supply for the wakeup source and core power must be retained. All other power domains can be turned on/off individually ■ The states of the configuration registers, buffer memory and all internal RAM are maintained ■ All transactions must be completed before FX3 enters Suspend mode (state of outstanding transactions are not preserved) ■ The firmware resumes operation from where it was suspended (except when woken up by RESET# assertion) because the program counter does not reset 	<ul style="list-style-type: none"> ■ Firmware executing on ARM926EJ-S core can put FX3 into suspend mode. For example, on USB suspend condition, firmware may decide to put FX3 into suspend mode ■ External Processor, through the use of mailbox registers can put FX3 into suspend mode 	<ul style="list-style-type: none"> ■ D+ transitioning to low or high ■ D- transitioning to low or high ■ Impedance change on OTG_ID pin ■ Resume condition on SSRX± ■ Detection of VBUS ■ Level detect on UART_CTS (programmable polarity) ■ GPIF II interface assertion of CTL[0] ■ Assertion of RESET#

Table 6. Entry and Exit Methods for Low-Power Modes (continued)

Low-Power Mode	Characteristics	Methods of Entry	Methods of Exit
Standby Mode (L3)	<ul style="list-style-type: none"> ■ The power consumption in this mode does not exceed ISB₃ ■ All configuration register settings and program/data RAM contents are preserved. However, data in the buffers or other parts of the data path, if any, is not guaranteed. Therefore, the external processor should take care that the data needed is read before putting FX3 into this Standby Mode ■ The program counter is reset after waking up from Standby ■ GPIO pins maintain their configuration ■ Crystal oscillator is turned off ■ Internal PLL is turned off ■ USB transceiver is turned off ■ ARM926EJ-S core is powered down. Upon wakeup, the core re-starts and runs the program stored in the program/data RAM ■ Power supply for the wakeup source and core power must be retained. All other power domains can be turned on/off individually 	<ul style="list-style-type: none"> ■ Firmware executing on ARM926EJ-S core or external processor configures the appropriate register 	<ul style="list-style-type: none"> ■ Detection of VBUS ■ Level detect on UART_CTS (Programmable Polarity) ■ GPIF II interface assertion of CTL[0] ■ Assertion of RESET#
Core Power Down Mode (L4)	<ul style="list-style-type: none"> ■ The power consumption in this mode does not exceed ISB₄ ■ Core power is turned off ■ All buffer memory, configuration registers, and the program RAM do not maintain state. After exiting this mode, reload the firmware ■ In this mode, all other power domains can be turned on/off individually 	<ul style="list-style-type: none"> ■ Turn off V_{DD} 	<ul style="list-style-type: none"> ■ Reapply VDD ■ Assertion of RESET#

Configuration Options

Configuration options are available for specific usage models. Contact Cypress Applications or Marketing for details.

Digital I/Os

FX3 has internal firmware-controlled pull-up or pull-down resistors on all digital I/O pins. An internal 50-kΩ resistor pulls the pins high, while an internal 10-kΩ resistor pulls the pins low to prevent them from floating. The I/O pins may have the following states:

- Tristated (High-Z)
- Weak pull-up (via internal 50 kΩ)
- Pull-down (via internal 10 kΩ)
- Hold (I/O hold its value) when in low-power modes
- The JTAG TDI, TMC, and TRST# signals have fixed 50-kΩ internal pull-ups, and the TCK signal has a fixed 10-kΩ pull-down resistor.

All unused I/Os should be pulled high by using the internal pull-up resistors. All unused outputs should be left floating. All I/Os can be driven at full-strength, three-quarter strength, half-strength, or quarter-strength. These drive strengths are configured separately for each interface.

GPIOs

EZ-USB enables a flexible pin configuration both on the GPIF II and the serial peripheral interfaces. Any unused control pins (except CTL[15]) on the GPIF II interface can be used as GPIOs.

Pin Configurations

Similarly, any unused pins on the serial peripheral interfaces may be configured as GPIOs. See [Pin Configurations](#) for pin configuration options.

All GPIF II and GPIO pins support an external load of up to 16 pF for every pin.

EMI

FX3 meets EMI requirements outlined by FCC 15B (USA) and EN55022 (Europe) for consumer electronics. FX3 can tolerate reasonable EMI, conducted by the aggressor, outlined by these specifications and continue to function as expected.

System-level ESD

FX3 has built-in ESD protection on the D+, D-, and GND pins on the USB interface. The ESD protection levels provided on these ports are:

- ±2.2-KV human body model (HBM) based on JESD22-A114 Specification
- ±6-KV contact discharge and ±8-KV air gap discharge based on IEC61000-4-2 level 3A
- ± 8-KV Contact Discharge and ±15-KV Air Gap Discharge based on IEC61000-4-2 level 4C.

This protection ensures the device continues to function after ESD events up to the levels stated in this section.

The SSRX+, SSRX-, SSTX+, and SSTX- pins only have up to ±2.2-KV HBM internal ESD protection.

Figure 7. FX3 121-ball BGA Ball Map (Top View)

	1	2	3	4	5	6	7	8	9	10	11
A	U3VSSQ	U3RXVDDQ	SSRXM	SSRXP	SSTXP	SSTXM	AVDD	VSS	DP	DM	NC
B	VIO4	FSLC[0]	R_USB3	FSLC[1]	U3TXVDDQ	CVDDQ	AVSS	VSS	VSS	VDD	TRST#
C	GPIQ[54]	GPIQ[55]	VDD	GPIQ[57]	RESET#	XTALIN	XTALOUT	R_USB2	OTG_ID	TDO	VIO5
D	GPIQ[50]	GPIQ[51]	GPIQ[52]	GPIQ[53]	GPIQ[56]	CLKIN_32	CLKIN	VSS	I2C_GPIQ[58]	I2C_GPIQ[59]	Q[60]
E	GPIQ[47]	VSS	VIO3	GPIQ[49]	GPIQ[48]	FSLC[2]	TDI	TMS	VDD	VBATT	VBUS
F	VIO2	GPIQ[45]	GPIQ[44]	GPIQ[41]	GPIQ[46]	TCK	GPIQ[2]	GPIQ[5]	GPIQ[1]	GPIQ[0]	VDD
G	VSS	GPIQ[42]	GPIQ[43]	GPIQ[30]	GPIQ[25]	GPIQ[22]	GPIQ[21]	GPIQ[15]	GPIQ[4]	GPIQ[3]	VSS
H	VDD	GPIQ[39]	GPIQ[40]	GPIQ[31]	GPIQ[29]	GPIQ[26]	GPIQ[20]	GPIQ[24]	GPIQ[7]	GPIQ[6]	VIO1
J	GPIQ[38]	GPIQ[36]	GPIQ[37]	GPIQ[34]	GPIQ[28]	GPIQ[16]	GPIQ[19]	GPIQ[14]	GPIQ[9]	GPIQ[8]	VDD
K	GPIQ[35]	GPIQ[33]	VSS	VSS	GPIQ[27]	GPIQ[23]	GPIQ[18]	GPIQ[17]	GPIQ[13]	GPIQ[12]	GPIQ[10]
L	VSS	VSS	VSS	GPIQ[32]	VDD	VSS	VDD	INT#	VIO1	GPIQ[11]	VSS

Figure 8. FX3 131-Ball CSP Ball Map (Bottom View)

	12	11	10	9	8	7	6	5	4	3	2	1
A	VSS	VSS	SSRXM		SSTXM	FSLC[0]	AVSS	AVDD	DP	VSS	DM	VDD
B	GPIO[55]	VIO4	SSRXP	R_USB3	SSTXP	FSLC[2]	XTALIN	XTALOUT	NC	R_USB2	NC	VDD
C	GPIO[56]	VIO3	U3RXVDDQ	U3VSSQ	U3TXVDDQ	CVDDQ	CLKIN_32	CLKIN	VSS	OTG_ID	TDO	TRST#
D	GPIO[49]	GPIO[50]	GPIO[53]	GPIO[54]	RESET#	VDD	I2C_GPIO[58]	TMS	VIO5	TCK	I2C_GPIO[59]	VSS
E	GPIO[57]	GPIO[48]	GPIO[51]	GPIO[52]	O[60]	VSS	VSS	VSS	VSS	GPIO[3]	VBATT	VBUS
F	VSS	GPIO[46]	GPIO[47]	FSLC[1]	TDI	VDD	VDD	VDD	VDD	GPIO[4]	GPIO[1]	GPIO[0]
G	VIO2	GPIO[43]	GPIO[44]	GPIO[45]	VSS	VSS	VDD	VSS	GPIO[9]	GPIO[7]	GPIO[6]	GPIO[2]
H	VSS	GPIO[40]	GPIO[41]	GPIO[42]	GPIO[39]	VSS	GPIO[20]	GPIO[18]	GPIO[14]	GPIO[12]	GPIO[8]	VIO1
J	VIO2	GPIO[38]	GPIO[37]	GPIO[36]	GPIO[31]	GPIO[27]	GPIO[25]	GPIO[22]	GPIO[19]	GPIO[15]	GPIO[10]	GPIO[5]
K	GPIO[35]	GPIO[34]	GPIO[33]	GPIO[32]	GPIO[28]	GPIO[26]	GPIO[16]	GPIO[21]	INT#	GPIO[24]	GPIO[11]	VSS
L	VDD	VSS	VDD	GPIO[30]	GPIO[29]	VIO1	GPIO[23]	VSS	VIO1	GPIO[17]	GPIO[13]	VSS

Note No ball is populated at location A9

Pin Description

Table 7. CYUSB3012 and CYUSB3014 Pin List (GPIF II with 32-bit Data Bus Width)

BGA	WLCSP		I/O	Name	Description	
					GPIF II (VIO1 Power Domain)	
					GPIF II Interface	Slave FIFO Interface
F10	F1	VIO1	I/O	GPIO[0]	DQ[0]	DQ[0]
F9	F2	VIO1	I/O	GPIO[1]	DQ[1]	DQ[1]
F7	G1	VIO1	I/O	GPIO[2]	DQ[2]	DQ[2]
G10	E3	VIO1	I/O	GPIO[3]	DQ[3]	DQ[3]
G9	F3	VIO1	I/O	GPIO[4]	DQ[4]	DQ[4]
F8	J1	VIO1	I/O	GPIO[5]	DQ[5]	DQ[5]
H10	G2	VIO1	I/O	GPIO[6]	DQ[6]	DQ[6]
H9	G3	VIO1	I/O	GPIO[7]	DQ[7]	DQ[7]
J10	H2	VIO1	I/O	GPIO[8]	DQ[8]	DQ[8]
J9	G4	VIO1	I/O	GPIO[9]	DQ[9]	DQ[9]
K11	J2	VIO1	I/O	GPIO[10]	DQ[10]	DQ[10]
L10	K2	VIO1	I/O	GPIO[11]	DQ[11]	DQ[11]
K10	H3	VIO1	I/O	GPIO[12]	DQ[12]	DQ[12]
K9	L2	VIO1	I/O	GPIO[13]	DQ[13]	DQ[13]
J8	H4	VIO1	I/O	GPIO[14]	DQ[14]	DQ[14]
G8	J3	VIO1	I/O	GPIO[15]	DQ[15]	DQ[15]
J6	K6	VIO1	I/O	GPIO[16]	PCLK	CLK
K8	L3	VIO1	I/O	GPIO[17]	CTL[0]	SLCS#
K7	H5	VIO1	I/O	GPIO[18]	CTL[1]	SLWR#
J7	J4	VIO1	I/O	GPIO[19]	CTL[2]	SLOE#
H7	H6	VIO1	I/O	GPIO[20]	CTL[3]	SLRD#
G7	K5	VIO1	I/O	GPIO[21]	CTL[4]	FLAGA
G6	J5	VIO1	I/O	GPIO[22]	CTL[5]	FLAGB
K6	L6	VIO1	I/O	GPIO[23]	CTL[6]	GPIO
H8	K3	VIO1	I/O	GPIO[24]	CTL[7]	PKTEND#
G5	J6	VIO1	I/O	GPIO[25]	CTL[8]	GPIO
H6	K7	VIO1	I/O	GPIO[26]	CTL[9]	GPIO
K5	J7	VIO1	I/O	GPIO[27]	CTL[10]	GPIO
J5	K8	VIO1	I/O	GPIO[28]	CTL[11]	A1
H5	L8	VIO1	I/O	GPIO[29]	CTL[12]	A0
G4	L9	VIO1	I/O	GPIO[30]	PMODE[0]	PMODE[0]
H4	J8	VIO1	I/O	GPIO[31]	PMODE[1]	PMODE[1]
L4	K9	VIO1	I/O	GPIO[32]	PMODE[2]	PMODE[2]
L8	K4	VIO1	I/O	INT#	INT#/CTL[15]	CTL[15]
C5	D8	CVDDQ	I	RESET#	RESET#	RESET#

Note

3. When GPIF II is configured for the 32-bit data bus width, GPIO[50]-GPIO[52] may be configured as GPIOs or I2S, and GPIO[53] to GPIO[56] may be configured as GPIOs or UART interface only.

Table 7. CYUSB3012 and CYUSB3014 Pin List (GPIF II with 32-bit Data Bus Width) (continued)

BGA	WLCSP		I/O	Name	Description							
IO2 (VIO2 Power Domain)												
GPIF II (32-bit data mode)												
K2	K10	VIO2	I/O	GPIO[33]	DQ[16]				GPIO			
J4	K11	VIO2	I/O	GPIO[34]	DQ[17]				GPIO			
K1	K12	VIO2	I/O	GPIO[35]	DQ[18]				GPIO			
J2	J9	VIO2	I/O	GPIO[36]	DQ[19]				GPIO			
J3	J10	VIO2	I/O	GPIO[37]	DQ[20]				GPIO			
J1	J11	VIO2	I/O	GPIO[38]	DQ[21]				GPIO			
H2	H8	VIO2	I/O	GPIO[39]	DQ[22]				GPIO			
H3	H11	VIO2	I/O	GPIO[40]	DQ[23]				GPIO			
F4	H10	VIO2	I/O	GPIO[41]	DQ[24]				GPIO			
G2	H9	VIO2	I/O	GPIO[42]	DQ[25]				GPIO			
G3	G11	VIO2	I/O	GPIO[43]	DQ[26]				GPIO			
F3	G10	VIO2	I/O	GPIO[44]	DQ[27]				GPIO			
F2	G09	VIO2	I/O	GPIO[45]	GPIO							
IO3 (VIO3 Power Domain)												
					GPIO + SPI	GPIO + UART	GPIO only	GPIF II - 32b + I2S + UART ^[3]	GPIO + I2S	UART + SPI + I2S		
F5	F11	VIO3	I/O	GPIO[46]	GPIO	GPIO	GPIO	DQ[28]	GPIO	UART_RT S		
E1	F10	VIO3	I/O	GPIO[47]	GPIO	GPIO	GPIO	DQ[29]	GPIO	UART_CT S		
E5	E11	VIO3	I/O	GPIO[48]	GPIO	GPIO	GPIO	DQ[30]	GPIO	UART_TX		
E4	D12	VIO3	I/O	GPIO[49]	GPIO	GPIO	GPIO	DQ[31]	GPIO	UART_R X		
D1	D11	VIO3	I/O	GPIO[50]	GPIO	GPIO	GPIO	I2S_CLK	GPIO	I2S_CLK		
D2	E10	VIO3	I/O	GPIO[51]	GPIO	GPIO	GPIO	I2S_SD	GPIO	I2S_SD		
D3	E9	VIO3	I/O	GPIO[52]	GPIO	GPIO	GPIO	I2S_WS	GPIO	I2S_WS		
IO4 (VIO4 Power Domain)												
D4	D10	VIO4	I/O	GPIO[53]	SPI_SCK	UART_RTS	GPIO	UART_RTS	GPIO	SPI_SCK		
C1	D9	VIO4	I/O	GPIO[54]	SPI_SSN	UART_CTS	GPIO	UART_CTS	I2S_CLK	SPI_SSN		
C2	B12	VIO4	I/O	GPIO[55]	SPI_MISO	UART_TX	GPIO	UART_TX	I2S_SD	SPI_MIS O		
D5	C12	VIO4	I/O	GPIO[56]	SPI_MOSI	UART_RX	GPIO	UART_RX	I2S_WS	SPI_MOS I		
C4	E12	VIO4	I/O	GPIO[57]	GPIO	GPIO	GPIO	I2S_MCLK	I2S_MCL K	I2S_MCL K		
USB Port (VBATT/VBUS Power Domain)												
C9	C3	VBUS/ VBATT	I	OTG_ID	OTG_ID							
USB Port (U3TXVDDQ/U3RXVDDQ Power Domain)												
A3	A10	U3RXVD DQ	I	SSRXM	SSRX-							
A4	B10	U3RXVD DQ	I	SSRXP	SSRX+							
A6	A8	U3TXVD DQ	O	SSTXM	SSTX-							
A5	B8	U3TXVD DQ	O	SSTXP	SSTX+							

Table 7. CYUSB3012 and CYUSB3014 Pin List (GPIF II with 32-bit Data Bus Width) (continued)

BGA	WLCSP		I/O	Name	Description
USB Port (VBATT/VBUS Power Domain)					
A9	A4	VBUS/VBATT	I/O	DP	D+
A10	A2	VBUS/VBATT	I/O	DM	D-
	B4			NC	No connect
A11	B2			NC	No connect
Crystal/Clocks (CVDDQ Power Domain)					
B2	A7	CVDDQ	I	FSLC[0]	FSLC[0]
C6	B6	AVDD	I/O	XTALIN	XTALIN
C7	B5	AVDD	I/O	XTALOUT	XTALOUT
B4	F9	CVDDQ	I	FSLC[1]	FSLC[1]
E6	B7	CVDDQ	I	FSLC[2]	FSLC[2]
D7	C5	CVDDQ	I	CLKIN	CLKIN
D6	C6	CVDDQ	I	CLKIN_32	CLKIN_32
I2C and JTAG (VIO5 Power Domain)					
D9	D6	VIO5	I/O	I2C_GPIO[58]	I ² C_SCL
D10	D2	VIO5	I/O	I2C_GPIO[59]	I ² C_SDA
E7	F8	VIO5	I	TDI	TDI
C10	C2	VIO5	O	TDO	TDO
B11	C1	VIO5	I	TRST#	TRST#
E8	D5	VIO5	I	TMS	TMS
F6	D3	VIO5	I	TCK	TCK
D11	E8	VIO5	O	O[60]	Charger detect output
Power					
E10	E2		PWR	VBATT	
B10	B1		PWR	VDD	
	A1		PWR	VDD	
A1	C9		PWR	U3VSSQ	
E11	E1		PWR	VBUS	
D8	C4		PWR	VSS	
H11	H1		PWR	VIO1	
E2	K1		PWR	VSS	
L9	L4		PWR	VIO1	
G1	L5		PWR	VSS	
	L7		PWR	VIO1	
	L1		PWR	VSS	
F1	J12		PWR	VIO2	
G11	H12		PWR	VSS	
	G12		PWR	VIO2	
E3	C11		PWR	VIO3	
L1	F12		PWR	VSS	
B1	B11		PWR	VIO4	
L6	A11		PWR	VSS	
	A12		PWR	VSS	
B6	C7		PWR	CVDDQ	
B5	C8		PWR	U3TXVDDQ	
A2	C10		PWR	U3RXVDDQ	
C11	D4		PWR	VIO5	

Table 7. CYUSB3012 and CYUSB3014 Pin List (GPIF II with 32-bit Data Bus Width) (continued)

BGA	WLCSP		I/O	Name	Description
L11	A3		PWR	VSS	
A7	A5		PWR	AVDD	
B7	A6		PWR	AVSS	
C3	F4		PWR	VDD	
B8	D1		PWR	VSS	
E9	F5		PWR	VDD	
B9	E4		PWR	VSS	
F11	F6		PWR	VDD	
	E5		PWR	VSS	GND
	F7		PWR	VDD	
	E6		PWR	VSS	GND
	E7		PWR	VSS	GND
H1	G6		PWR	VDD	
L7	D7		PWR	VDD	
J11	L10		PWR	VDD	
L5	L12		PWR	VDD	
K4	H7		PWR	VSS	
L3	G7		PWR	VSS	
K3	L11		PWR	VSS	
L2	G8		PWR	VSS	
A8	G5		PWR	VSS	
					Precision Resistors
C8	B3	VBUS/ BATT	I/O	R_usb2	Precision resistor for USB 2.0 (Connect a 6.04 kΩ ±1% resistor between this pin and GND)
B3	B9	U3TXVD DQ	I/O	R_usb3	Precision resistor for USB 3.0 (Connect a 200 Ω ±1% resistor between this pin and GND)

Table 8. CYUSB3011 and CYUSB3013 Pin List (GPIF II with 16-bit Data Bus Width)

Pin		I/O	Name	Description	
				GPIF II (VIO1 Power Domain)	
				GPIF II Interface	Slave FIFO Interface
F10	VIO1	I/O	GPIO[0]	DQ[0]	DQ[0]
F9	VIO1	I/O	GPIO[1]	DQ[1]	DQ[1]
F7	VIO1	I/O	GPIO[2]	DQ[2]	DQ[2]
G10	VIO1	I/O	GPIO[3]	DQ[3]	DQ[3]
G9	VIO1	I/O	GPIO[4]	DQ[4]	DQ[4]
F8	VIO1	I/O	GPIO[5]	DQ[5]	DQ[5]
H10	VIO1	I/O	GPIO[6]	DQ[6]	DQ[6]
H9	VIO1	I/O	GPIO[7]	DQ[7]	DQ[7]
J10	VIO1	I/O	GPIO[8]	DQ[8]	DQ[8]
J9	VIO1	I/O	GPIO[9]	DQ[9]	DQ[9]
K11	VIO1	I/O	GPIO[10]	DQ[10]	DQ[10]
L10	VIO1	I/O	GPIO[11]	DQ[11]	DQ[11]
K10	VIO1	I/O	GPIO[12]	DQ[12]	DQ[12]
K9	VIO1	I/O	GPIO[13]	DQ[13]	DQ[13]
J8	VIO1	I/O	GPIO[14]	DQ[14]	DQ[14]
G8	VIO1	I/O	GPIO[15]	DQ[15]	DQ[15]

Table 8. CYUSB3011 and CYUSB3013 Pin List (GPIF II with 16-bit Data Bus Width) (continued)

Pin		I/O	Name	Description							
J6	VIO1	I/O	GPIO[16]	PCLK			CLK				
K8	VIO1	I/O	GPIO[17]	CTL[0]			SLCS#				
K7	VIO1	I/O	GPIO[18]	CTL[1]			SLWR#				
J7	VIO1	I/O	GPIO[19]	CTL[2]			SLOE#				
H7	VIO1	I/O	GPIO[20]	CTL[3]			SLRD#				
G7	VIO1	I/O	GPIO[21]	CTL[4]			FLAGA				
G6	VIO1	I/O	GPIO[22]	CTL[5]			FLAGB				
K6	VIO1	I/O	GPIO[23]	CTL[6]			GPIO				
H8	VIO1	I/O	GPIO[24]	CTL[7]			PKTEND#				
G5	VIO1	I/O	GPIO[25]	CTL[8]			GPIO				
H6	VIO1	I/O	GPIO[26]	CTL[9]			GPIO				
K5	VIO1	I/O	GPIO[27]	CTL[10]			GPIO				
J5	VIO1	I/O	GPIO[28]	CTL[11]			A1				
H5	VIO1	I/O	GPIO[29]	CTL[12]			A0				
G4	VIO1	I/O	GPIO[30]	PMODE[0]			PMODE[0]				
H4	VIO1	I/O	GPIO[31]	PMODE[1]			PMODE[1]				
L4	VIO1	I/O	GPIO[32]	PMODE[2]			PMODE[2]				
L8	VIO1	I/O	INT#	INT#/CTL[15]			CTL[15]				
C5	CVDDQ	I	RESET#	RESET#			RESET#				
IO2 (VIO2 Power Domain)											
K2	VIO2	I/O	GPIO[33]	GPIO							
J4	VIO2	I/O	GPIO[34]	GPIO							
K1	VIO2	I/O	GPIO[35]	GPIO							
J2	VIO2	I/O	GPIO[36]	GPIO							
J3	VIO2	I/O	GPIO[37]	GPIO							
J1	VIO2	I/O	GPIO[38]	GPIO							
H2	VIO2	I/O	GPIO[39]	GPIO							
H3	VIO2	I/O	GPIO[40]	GPIO							
F4	VIO2	I/O	GPIO[41]	GPIO							
G2	VIO2	I/O	GPIO[42]	GPIO							
G3	VIO2	I/O	GPIO[43]	GPIO							
F3	VIO2	I/O	GPIO[44]	GPIO							
F2	VIO2	I/O	GPIO[45]	GPIO							
IO3 (VIO3 Power Domain)											
F5	VIO3	I/O	GPIO[46]	GPIO							
E1	VIO3	I/O	GPIO[47]	GPIO							
E5	VIO3	I/O	GPIO[48]	GPIO							
E4	VIO3	I/O	GPIO[49]	GPIO							
D1	VIO3	I/O	GPIO[50]	GPIO	GPIO	GPIO	I2S_CLK	GPIO	I2S_CLK		
D2	VIO3	I/O	GPIO[51]	GPIO	GPIO	GPIO	I2S_SD	GPIO	I2S_SD		
D3	VIO3	I/O	GPIO[52]	GPIO	GPIO	GPIO	I2S_WS	GPIO	I2S_WS		
IO4 (VIO4) Power Domain											
D4	VIO4	I/O	GPIO[53]	SPI_SCK	UART_RTS	GPIO	UART_RTS	GPIO	SPI_SCK		
C1	VIO4	I/O	GPIO[54]	SPI_SSN	UART_CTS	GPIO	UART_CTS	I2S_CLK	SPI_SSN		
C2	VIO4	I/O	GPIO[55]	SPI_MISO	UART_TX	GPIO	UART_TX	UART_TX	SPI_MISO		
D5	VIO4	I/O	GPIO[56]	SPI_MOSI	UART_RX	GPIO	UART_RX	UART_RX	SPI_MOSI		

Table 8. CYUSB3011 and CYUSB3013 Pin List (GPIF II with 16-bit Data Bus Width) (continued)

Pin		I/O	Name	Description					
C4	VIO4	I/O	GPIO[57]	GPIO	GPIO	GPIO	I2S_MCLK	I2S_MCLK	I2S_MCLK
USB Port (VBATT/VBUS Power Domain)									
C9	VBUS/ VBATT	I	OTG_ID	OTG_ID					
USB Port (U3TXVDDQ/U3RXVDDQ Power Domain)									
A3	U3RXVDDQ	I	SSRXM	SSRX-					
A4	U3RXVDDQ	I	SSRXP	SSRX+					
A6	U3TXVDDQ	O	SSTXM	SSTX-					
A5	U3TXVDDQ	O	SSTXP	SSTX+					
USB Port (VBATT/VBUS Power Domain)									
A9	VBUS/VBATT	I/O	DP	D+					
A10	VBUS/VBATT	I/O	DM	D-					
A11			NC	No connect					
Crystal/Clocks (CVDDQ Power Domain)									
B2	CVDDQ	I	FSLC[0]	FSLC[0]					
C6	AVDD	I/O	XTALIN	XTALIN					
C7	AVDD	I/O	XTALOUT	XTALOUT					
B4	CVDDQ	I	FSLC[1]	FSLC[1]					
E6	CVDDQ	I	FSLC[2]	FSLC[2]					
D7	CVDDQ	I	CLKIN	CLKIN					
D6	CVDDQ	I	CLKIN_32	CLKIN_32					
I2C and JTAG (VIO5 Power Domain)									
D9	VIO5	I/O	I2C_GPIO[58]	I ² C_SCL					
D10	VIO5	I/O	I2C_GPIO[59]	I ² C_SDA					
E7	VIO5	I	TDI	TDI					
C10	VIO5	O	TDO	TDO					
B11	VIO5	I	TRST#	TRST#					
E8	VIO5	I	TMS	TMS					
F6	VIO5	I	TCK	TCK					
D11	VIO5	O	O[60]	Charger detect output					
Power									
E10		PWR	VBATT						
B10		PWR	VDD						
A1		PWR	U3VSSQ						
E11		PWR	VBUS						
D8		PWR	VSS						
H11		PWR	VIO1						
E2		PWR	VSS						
L9		PWR	VIO1						
G1		PWR	VSS						
F1		PWR	VIO2						
G11		PWR	VSS						
E3		PWR	VIO3						
L1		PWR	VSS						
B1		PWR	VIO4						
L6		PWR	VSS						

Table 8. CYUSB3011 and CYUSB3013 Pin List (GPIF II with 16-bit Data Bus Width) (continued)

Pin		I/O	Name	Description
B6		PWR	CVDDQ	
B5		PWR	U3TXVDDQ	
A2		PWR	U3RXVDDQ	
C11		PWR	VIO5	
L11		PWR	VSS	
A7		PWR	AVDD	
B7		PWR	AVSS	
C3		PWR	VDD	
B8		PWR	VSS	
E9		PWR	VDD	
B9		PWR	VSS	
F11		PWR	VDD	
H1		PWR	VDD	
L7		PWR	VDD	
J11		PWR	VDD	
L5		PWR	VDD	
K4		PWR	VSS	
L3		PWR	VSS	
K3		PWR	VSS	
L2		PWR	VSS	
A8		PWR	VSS	
				Precision Resistors
C8	VBUS/VBATT	I/O	R_usb2	Precision resistor for USB 2.0 (Connect a 6.04 k Ω \pm 1% resistor between this pin and GND)
B3	U3TXVDDQ	I/O	R_usb3	Precision resistor for USB 3.0 (Connect a 200 Ω \pm 1% resistor between this pin and GND)

Absolute Maximum Ratings

Exceeding maximum ratings may shorten the useful life of the device.

Storage temperature	-65 °C to +150 °C
Ambient temperature with power supplied (Industrial)	-40 °C to +85 °C
Ambient temperature with power supplied (Commercial)	0 °C to +70 °C
Supply voltage to ground potential V _{DD} , A _{VDDQ}	1.25 V
V _{IO1} , V _{IO2} , V _{IO3} , V _{IO4} , V _{IO5}	3.6 V
U3TX _{VDDQ} , U3RX _{VDDQ}	1.25 V
DC input voltage to any input pin	V _{CC} + 0.3 V
DC voltage applied to outputs in high Z state	V _{CC} + 0.3 V

(V_{CC} is the corresponding I/O voltage)

Static discharge voltage ESD protection levels:

- ± 2.2-KV HBM based on JESD22-A114
- Additional ESD protection levels on D+, D-, and GND pins, and serial peripheral pins

- ± 6-KV contact discharge, ± 8-KV air gap discharge based on IEC61000-4-2 level 3A, ± 8-KV contact discharge, and ± 15-KV air gap discharge based on IEC61000-4-2 level 4C

Latch-up current > 200 mA

Maximum output short-circuit current for all I/O configurations. (V_{out} = 0 V) -100 mA

Operating Conditions

T _A (ambient temperature under bias)	
Industrial	-40 °C to +85 °C
Commercial	0 °C to +70 °C
V _{DD} , A _{VDDQ} , U3TX _{VDDQ} , U3RX _{VDDQ}	
Supply voltage	1.15 V to 1.25 V
V _{BATT} supply voltage	3.2 V to 6 V
V _{IO1} , V _{IO2} , V _{IO3} , V _{IO4} , C _{VDDQ}	
Supply voltage	1.7 V to 3.6 V
V _{IO5} supply voltage	1.15 V to 3.6 V

DC Specifications

Parameter	Description	Min	Max	Units	Notes
V _{DD}	Core voltage supply	1.15	1.25	V	1.2-V typical
A _{VDD}	Analog voltage supply	1.15	1.25	V	1.2-V typical
V _{IO1}	GPIO II I/O power supply domain	1.7	3.6	V	1.8-, 2.5-, and 3.3-V typical
V _{IO2}	IO2 power supply domain	1.7	3.6	V	1.8-, 2.5-, and 3.3-V typical
V _{IO3}	IO3 power supply domain	1.7	3.6	V	1.8-, 2.5-, and 3.3-V typical
V _{IO4}	UART/SPI/I2S power supply domain	1.7	3.6	V	1.8-, 2.5-, and 3.3-V typical
V _{BATT}	USB voltage supply	3.2	6	V	3.7-V typical
V _{BUS}	USB voltage supply	4.0	6	V	5-V typical
U3TX _{VDDQ}	USB 3.0 1.2-V supply	1.15	1.25	V	1.2-V typical. A 22-µF bypass capacitor is required on this power supply.
U3RX _{VDDQ}	USB 3.0 1.2-V supply	1.15	1.25	V	1.2-V typical. A 22-µF bypass capacitor is required on this power supply.
C _{VDDQ}	Clock voltage supply	1.7	3.6	V	1.8-, 3.3-V typical
V _{IO5}	I ² C and JTAG voltage supply	1.15	3.6	V	1.2-, 1.8-, 2.5-, and 3.3-V typical
V _{IH1}	Input HIGH voltage 1	0.625 × V _{CC}	V _{CC} + 0.3	V	For 2.0 V ≤ V _{CC} ≤ 3.6 V (except USB port). V _{CC} is the corresponding I/O voltage supply.
V _{IH2}	Input HIGH voltage 2	V _{CC} - 0.4	V _{CC} + 0.3	V	For 1.7 V ≤ V _{CC} ≤ 2.0 V (except USB port). V _{CC} is the corresponding I/O voltage supply.
V _{IL}	Input LOW voltage	-0.3	0.25 × V _{CC}	V	V _{CC} is the corresponding I/O voltage supply.
V _{OH}	Output HIGH voltage	0.9 × V _{CC}	-	V	I _{OH} (max) = -100 µA tested at quarter drive strength. V _{CC} is the corresponding I/O voltage supply.

DC Specifications (continued)

Parameter	Description	Min	Max	Units	Notes
V _{OL}	Output LOW voltage	–	0.1 × VCC	V	I _{OL} (min) = +100 μA tested at quarter drive strength. VCC is the corresponding I/O voltage supply.
I _{Ix}	Input leakage current for all pins except SSTXP/SSXM/SSRXP/SSRXM	–1	1	μA	All I/O signals held at V _{DDQ} (For I/Os with a pull-up or pull-down resistor connected, the leakage current increases by V _{DDQ} /R _{pu} or V _{DDQ} /R _{pd})
I _{OZ}	Output High-Z leakage current for all pins except SSTXP/SSXM/SSRXP/SSRXM	–1	1	μA	All I/O signals held at V _{DDQ}
I _{CC Core}	Core and analog voltage operating current	–	200	mA	Total current through A _{VDD} , V _{DD}
I _{CC USB}	USB voltage supply operating current	–	60	mA	
I _{SB1}	Total suspend current during suspend mode with USB 3.0 PHY enabled (L1)	–	–	mA	Core current: 1.5 mA I/O current: 20 μA USB current: 2 mA For typical PVT (typical silicon, all power supplies at their respective nominal levels at 25 °C.)
I _{SB2}	Total suspend current during suspend mode with USB 3.0 PHY disabled (L2)	–	–	mA	Core current: 250 μA I/O current: 20 μA USB current: 1.2 mA For typical PVT (Typical silicon, all power supplies at their respective nominal levels at 25 °C.)
I _{SB3}	Total standby current during standby mode (L3)	–	–	μA	Core current: 60 μA I/O current: 20 μA USB current: 40 μA For typical PVT (typical silicon, all power supplies at their respective nominal levels at 25 °C.)
I _{SB4}	Total standby current during core power-down mode (L4)	–	–	μA	Core current: 0 μA I/O current: 20 μA USB current: 40 μA For typical PVT (typical silicon, all power supplies at their respective nominal levels at 25 °C.)
V _{RAMP}	Voltage ramp rate on core and I/O supplies	0.2	50	V/ms	Voltage ramp must be monotonic
V _N	Noise level permitted on V _{DD} and I/O supplies	–	100	mV	Max p-p noise level permitted on all supplies except A _{VDD}
V _{N_AVDD}	Noise level permitted on A _{VDD} supply	–	20	mV	Max p-p noise level permitted on A _{VDD}

AC Timing Parameters

GPIF II Timing

Figure 9. GPIF II Timing in Synchronous Mode

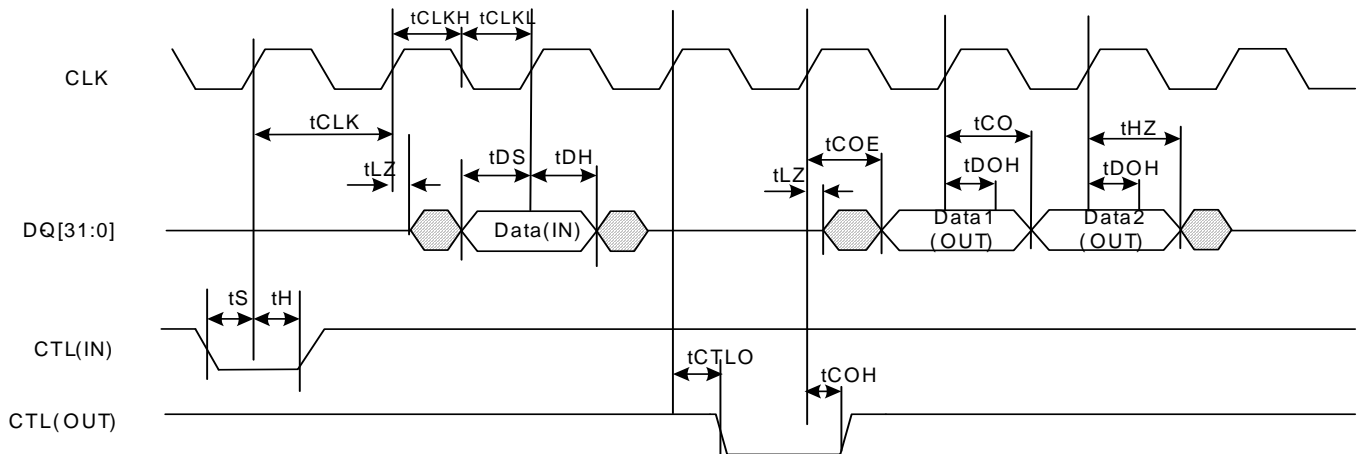

Table 9. GPIF II Timing Parameters in Synchronous Mode ^[4]

Parameter	Description	Min	Max	Units
Frequency	Interface clock frequency	–	100	MHz
tCLK	Interface clock period	10	–	ns
tCLKH	Clock high time	4	–	ns
tCLKL	Clock low time	4	–	ns
tS	CTL input to clock setup time	2	–	ns
tH	CTL input to clock hold time	0.5	–	ns
tDS	Data in to clock setup time	2	–	ns
tDH	Data in to clock hold time	0.5	–	ns
tCO	Clock to data out propagation delay when DQ bus is already in output direction	–	8	ns
tCOE	Clock to data out propagation delay when DQ lines change to output from tristate and valid data is available on the DQ bus	–	9	ns
tCTLO	Clock to CTL out propagation delay	–	8	ns
tDOH	Clock to data out hold	2	–	ns
tCOH	Clock to CTL out hold	0	–	ns
tHZ	Clock to high-Z	–	8	ns
tLZ	Clock to low-Z	0	–	ns

Note

4. All parameters guaranteed by design and validated through characterization.

Figure 10. GPIF II Timing in Asynchronous Mode

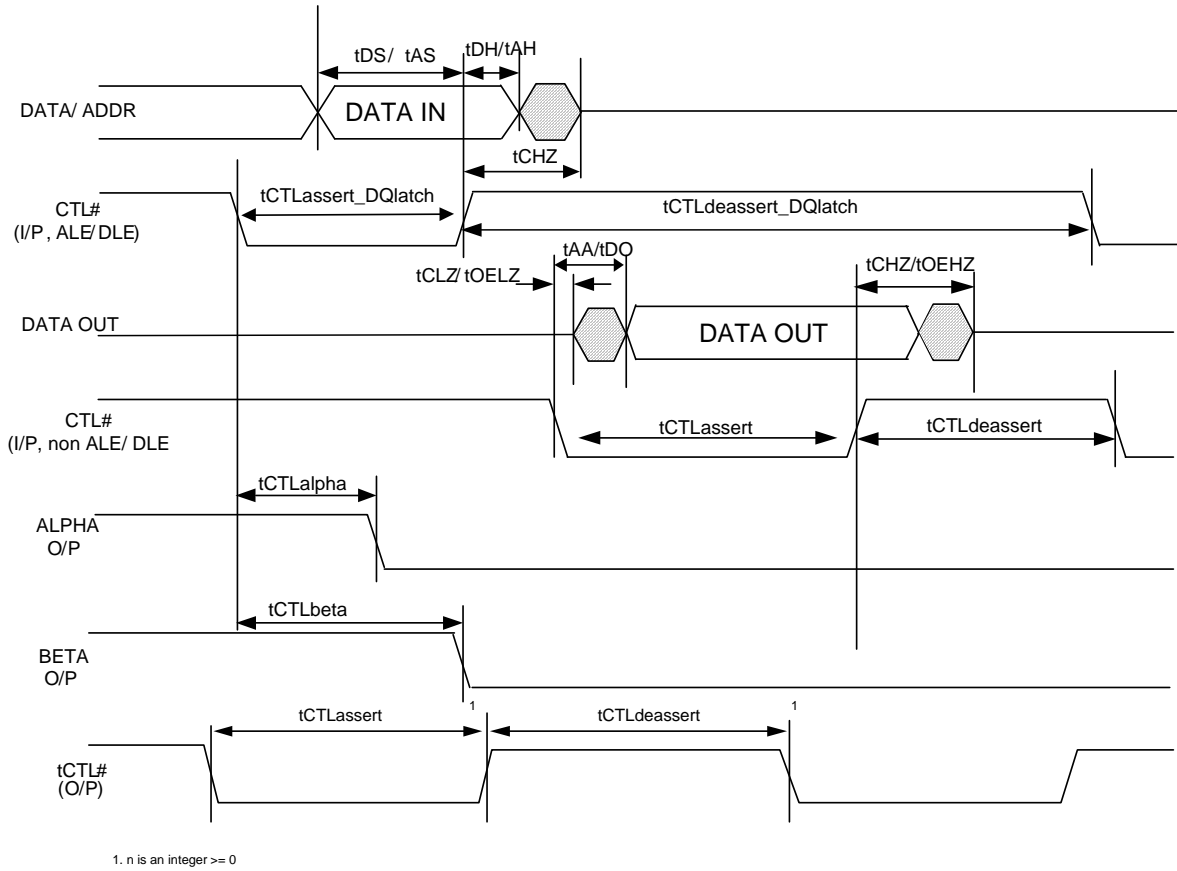

Figure 11. GPIF II Timing in Asynchronous DDR Mode

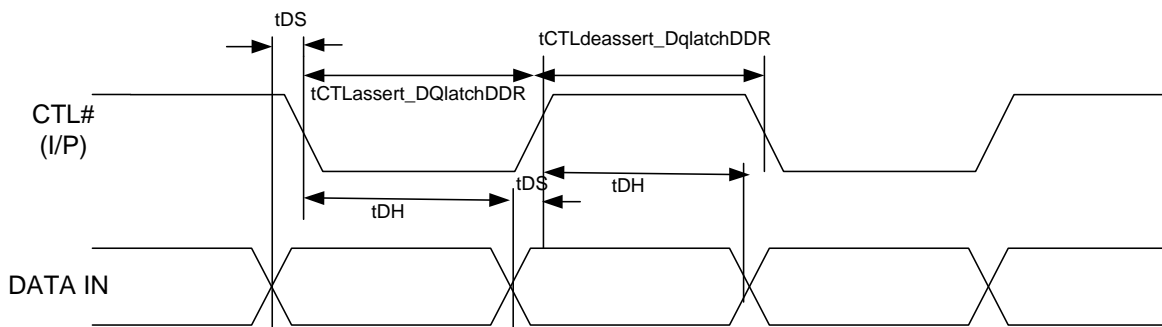

Table 10. GPIF II Timing in Asynchronous Mode^[5, 6]

Note The following parameters assume one state transition

Parameter	Description	Min	Max	Units
tDS	Data In to DLE setup time. Valid in DDR async mode.	2.3	–	ns
tDH	Data In to DLE hold time. Valid in DDR async mode.	2	–	ns
tAS	Address In to ALE setup time	2.3	–	ns
tAH	Address In to ALE hold time	2	–	ns
tCTLassert	CTL I/O asserted width for CTRL inputs without DQ input association and for outputs.	7	–	ns
tCTLdeassert	CTL I/O deasserted width for CTRL inputs without DQ input association and for outputs.	7	–	ns
tCTLassert_DQassert	CTL asserted pulse width for CTL inputs that signify DQ inputs valid at the asserting edge but do not employ in-built latches (ALE/DLE) for those DQ inputs.	20	–	ns
tCTLdeassert_DQassert	CTL deasserted pulse width for CTL inputs that signify DQ input valid at the asserting edge but do not employ in-built latches (ALE/DLE) for those DQ inputs.	7	–	ns
tCTLassert_DQdeassert	CTL asserted pulse width for CTL inputs that signify DQ inputs valid at the deasserting edge but do not employ in-built latches (ALE/DLE) for those DQ inputs.	7	–	ns
tCTLdeassert_DQdeassert	CTL deasserted pulse width for CTL inputs that signify DQ inputs valid at the deasserting edge but do not employ in-built latches (ALE/DLE) for those DQ inputs.	20	–	ns
tCTLassert_DQlatch	CTL asserted pulse width for CTL inputs that employ in-built latches (ALE/DLE) to latch the DQ inputs. In this non-DDR case, in-built latches are always close at the deasserting edge.	7	–	ns
tCTLdeassert_DQlatch	CTL deasserted pulse width for CTL inputs that employ in-built latches (ALE/DLE) to latch the DQ inputs. In this non-DDR case, in-built latches always close at the deasserting edge.	10	–	ns
tCTLassert_DQlatchDDR	CTL asserted pulse width for CTL inputs that employ in-built latches (DLE) to latch the DQ inputs in DDR mode.	10	–	ns
tCTLdeassert_DQlatchDDR	CTL deasserted pulse width for CTL inputs that employ in-built latches (DLE) to latch the DQ inputs in DDR mode.	10	–	ns
tAA	DQ/CTL input to DQ output time when DQ change or CTL change needs to be detected and affects internal updates of input and output DQ lines.	–	30	ns
tDO	CTL to data out when the CTL change merely enables the output flop update whose data was already established.	–	25	ns
tOELZ	CTL designated as OE to low-Z. Time when external devices should stop driving data.	0	–	ns
tOEHZ	CTL designated as OE to high-Z	8	8	ns
tCLZ	CTL (non-OE) to low-Z. Time when external devices should stop driving data.	0	–	ns
tCHZ	CTL (non-OE) to high-Z	30	30	ns
tCTLalpha	CTL to alpha change at output	–	25	ns
tCTLbeta	CTL to beta change at output	–	30	ns
tDST	Addr/data setup when DLE/ALE not used	2	–	ns
tDHT	Addr/data hold when DLE/ALE not used	20	–	ns

Notes

5. All parameters guaranteed by design and validated through characterization.

6. "alpha" output corresponds to "early output" and "beta" corresponds to "delayed output". Please refer to the GPIFII Designer Tool for the use of these outputs.

Slave FIFO Interface

Synchronous Slave FIFO Sequence Description

- FIFO address is stable and SLCS is asserted
- SLOE is asserted. SLOE is an output-enable only, whose sole function is to drive the data bus.
- SLRD is asserted
- The FIFO pointer is updated on the rising edge of the PCLK, while the SLRD is asserted. This starts the propagation of data from the newly addressed location to the data bus. After a propagation delay of t_{CO} (measured from the rising edge of

PCLK), the new data value is present. N is the first data value read from the FIFO. To have data on the FIFO data bus, SLOE must also be asserted.

The same sequence of events is shown for a burst read.

Note For burst mode, the SLRD# and SLOE# are asserted during the entire duration of the read. When SLOE# is asserted, the data bus is driven (with data from the previously addressed FIFO). For each subsequent rising edge of PCLK, while the SLRD# is asserted, the FIFO pointer is incremented and the next data value is placed on the data bus.

Figure 12. Synchronous Slave FIFO Read Mode

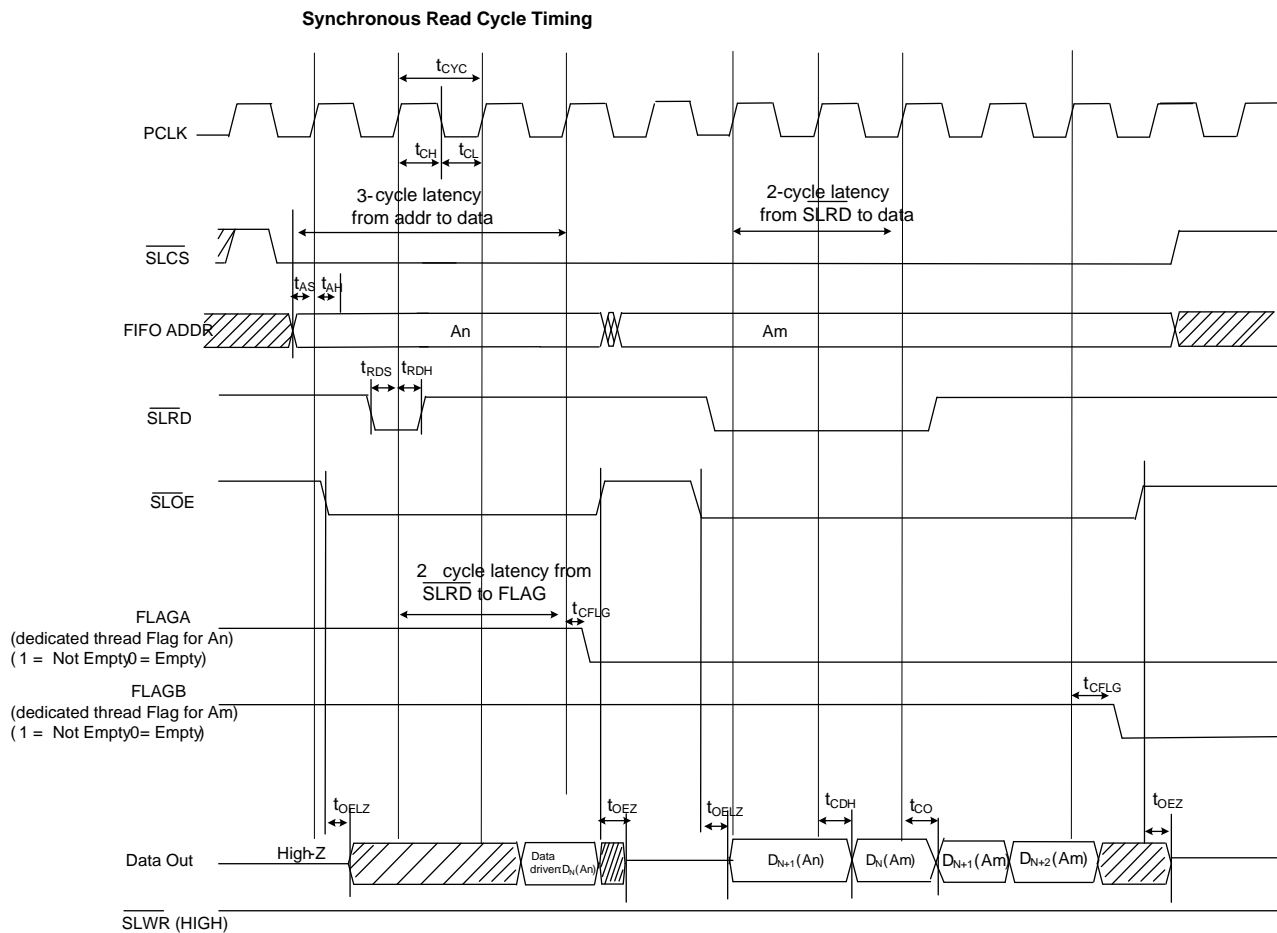

Synchronous Slave FIFO Write Sequence Description

- FIFO address is stable and the signal SLCS# is asserted
- External master or peripheral outputs the data to the data bus
- SLWR# is asserted
- While the SLWR# is asserted, data is written to the FIFO and on the rising edge of the PCLK, the FIFO pointer is incremented
- The FIFO flag is updated after a delay of t_{WFLG} from the rising edge of the clock

The same sequence of events is also shown for burst write

Note For the burst mode, SLWR# and SLCS# are asserted for the entire duration, during which all the required data values are written. In this burst write mode, after the SLWR# is asserted, the data on the FIFO data bus is written to the FIFO on every rising

edge of PCLK. The FIFO pointer is updated on each rising edge of PCLK.

Short Packet: A short packet can be committed to the USB host by using the PKTEND#. The external device or processor should be designed to assert the PKTEND# along with the last word of data and SLWR# pulse corresponding to the last word. The FIFOADDR lines must be held constant during the PKTEND# assertion.

Zero-Length Packet: The external device or processor can signal a Zero-Length Packet (ZLP) to FX3 simply by asserting PKTEND#, without asserting SLWR#. SLCS# and address must be driven as shown in Figure 13 on page 28.

FLAG Usage: The FLAG signals are monitored for flow control by the external processor. FLAG signals are outputs from FX3 that may be configured to show empty, full, or partial status for a dedicated thread or the current thread that is addressed.

Figure 13. Synchronous Slave FIFO Write Mode

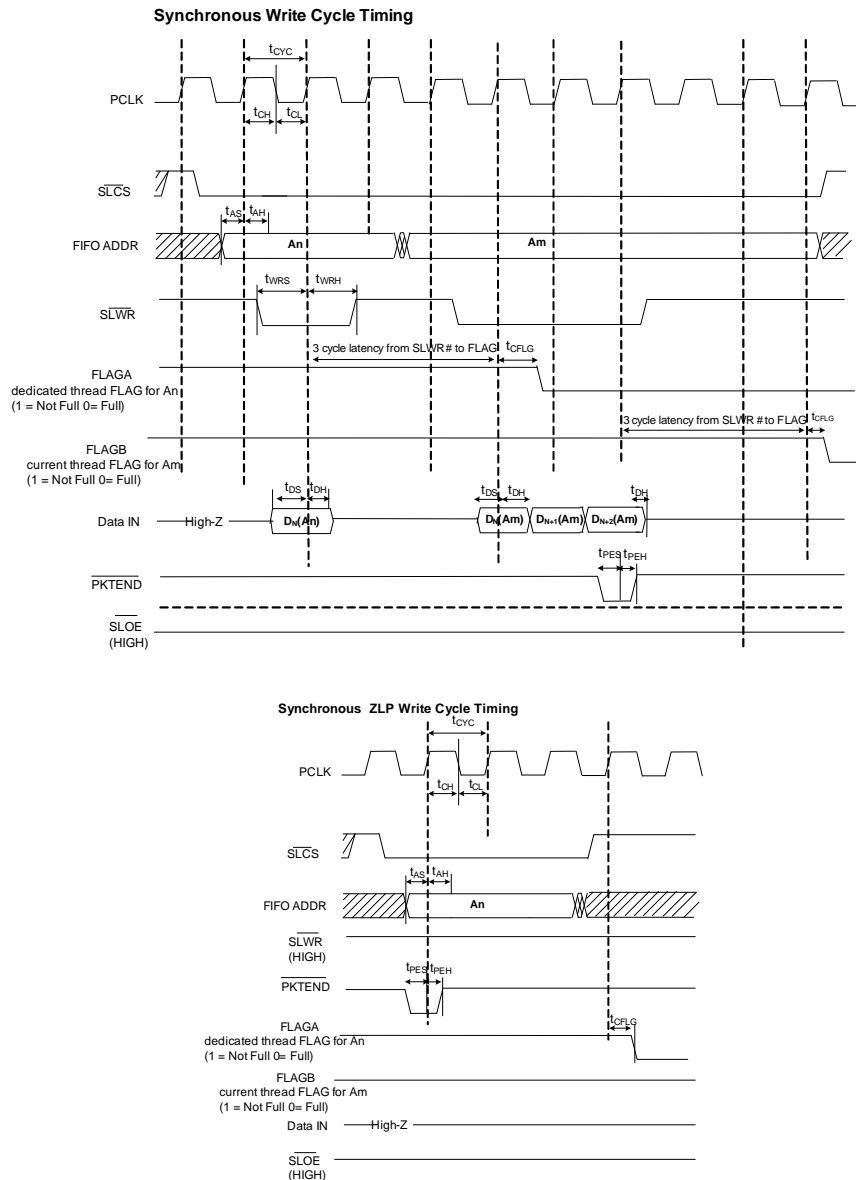

Table 11. Synchronous Slave FIFO Parameters^[7]

Parameter	Description	Min	Max	Units
FREQ	Interface clock frequency	–	100	MHz
tCYC	Clock period	10	–	ns
tCH	Clock high time	4	–	ns
tCL	Clock low time	4	–	ns
tRDS	SLRD# to CLK setup time	2	–	ns
tRDH	SLRD# to CLK hold time	0.5	–	ns
tWRS	SLWR# to CLK setup time	2	–	ns
tWRH	SLWR# to CLK hold time	0.5	–	ns
tCO	Clock to valid data	–	8	ns
tDS	Data input setup time	2	–	ns
tDH	CLK to data input hold	0.5	–	ns
tAS	Address to CLK setup time	2	–	ns
tAH	CLK to address hold time	0.5	–	ns
tOELZ	SLOE# to data low-Z	0	–	ns
tCFLG	CLK to flag output propagation delay	–	8	ns
tOEZ	SLOE# deassert to Data Hi Z	–	8	ns
tPES	PKTEND# to CLK setup	2	–	ns
tPEH	CLK to PKTEND# hold	0.5	–	
tCDH	CLK to data output hold	2	–	ns

Note Three-cycle latency from ADDR to DATA/FLAGS

Asynchronous Slave FIFO Read Sequence Description

- FIFO address is stable and the SLCS# signal is asserted.
- SLOE# is asserted. This results in driving the data bus.
- SLRD # is asserted.
- Data from the FIFO is driven after assertion of SLRD#. This data is valid after a propagation delay of tRDO from the falling edge of SLRD#.
- FIFO pointer is incremented on deassertion of SLRD#

In Figure 14, data N is the first valid data read from the FIFO. For data to appear on the data bus during the read cycle, SLOE# must be in an asserted state. SLRD# and SLOE# can also be tied.

The same sequence of events is also shown for a burst read.

Note In the burst read mode, during SLOE# assertion, the data bus is in a driven state (data is driven from a previously addressed FIFO). After assertion of SLRD# data from the FIFO is driven on the data bus (SLOE# must also be asserted). The FIFO pointer is incremented after deassertion of SLRD#.

Note

7. All parameters guaranteed by design and validated through characterization.

Figure 14. Asynchronous Slave FIFO Read Mode

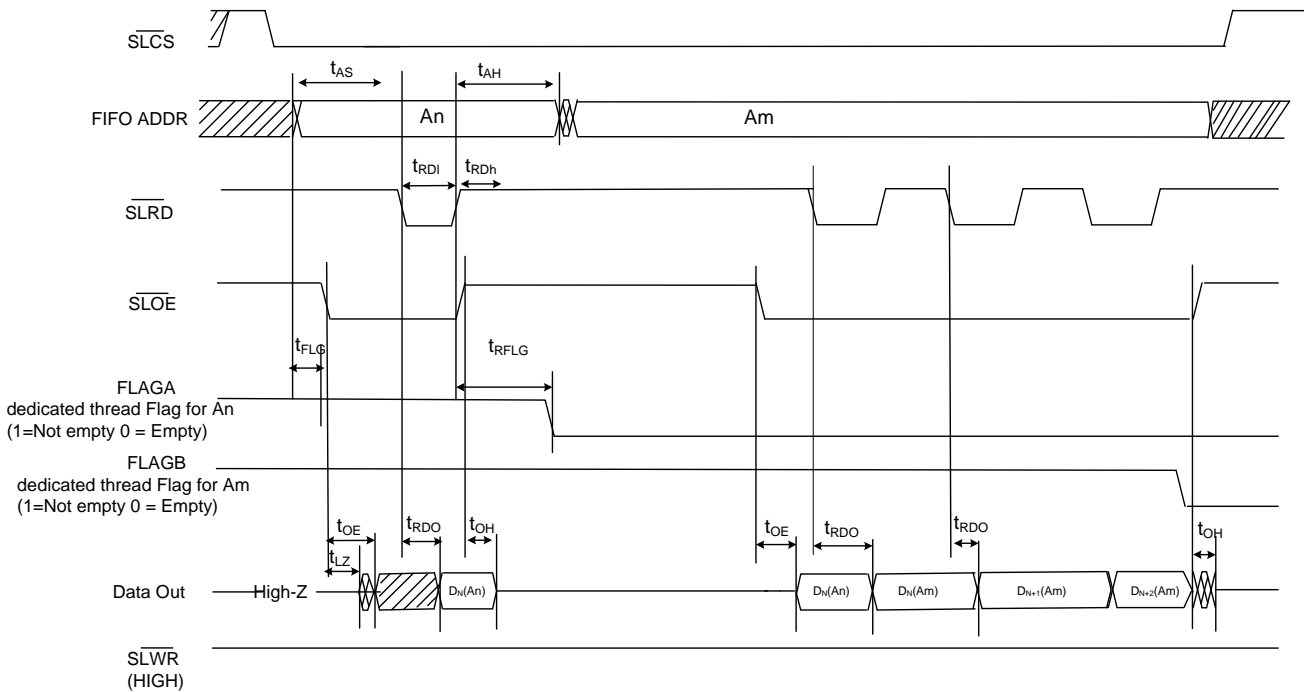

Asynchronous Slave FIFO Write Sequence Description

- FIFO address is driven and $\overline{SLCS\#}$ is asserted
- $\overline{SLWR\#}$ is asserted. $\overline{SLCS\#}$ must be asserted with $\overline{SLWR\#}$ or before $\overline{SLWR\#}$ is asserted
- Data must be present on the t_{WRS} bus before the deasserting edge of $\overline{SLWR\#}$
- Deassertion of $\overline{SLWR\#}$ causes the data to be written from the data bus to the FIFO, and then the FIFO pointer is incremented
- The FIFO flag is updated after the t_{WFLG} from the deasserting edge of $\overline{SLWR\#}$.

The same sequence of events is shown for a burst write.
 Note that in the burst write mode, after $\overline{SLWR\#}$ deassertion, the data is written to the FIFO, and then the FIFO pointer is incremented.

Short Packet: A short packet can be committed to the USB host by using the $\overline{PKTEND\#}$. The external device or processor should be designed to assert the $\overline{PKTEND\#}$ along with the last word of data and $\overline{SLWR\#}$ pulse corresponding to the last word. The $\overline{FIFOADDR}$ lines must be held constant during the $\overline{PKTEND\#}$ assertion.

Zero-Length Packet: The external device or processor can signal a zero-length packet (ZLP) to FX3 simply by asserting $\overline{PKTEND\#}$, without asserting $\overline{SLWR\#}$. $\overline{SLCS\#}$ and the address must be driven as shown in Figure 15 on page 31.

FLAG Usage: The FLAG signals are monitored by the external processor for flow control. FLAG signals are FX3 outputs that can be configured to show empty, full, and partial status for a dedicated address or the current address.

Figure 15. Asynchronous Slave FIFO Write Mode

Asynchronous Write Cycle Timing

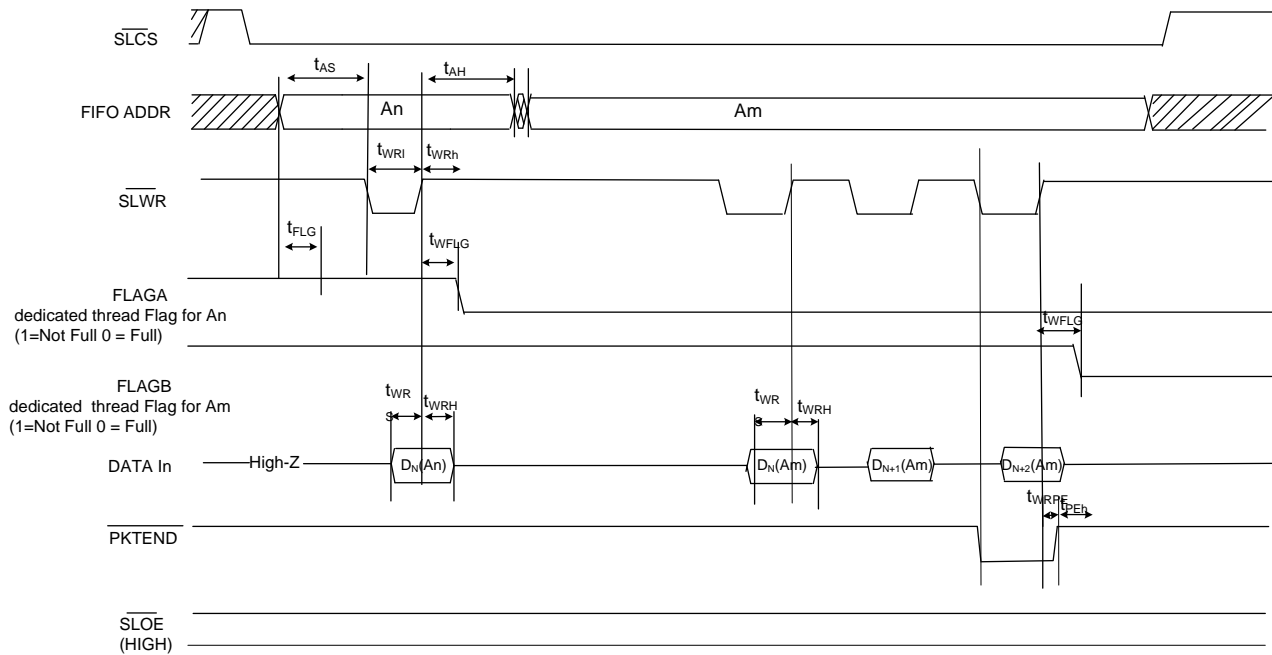

t_{WRPE} : $SLWR\#$ de-assert to $PKTEND$ deassert = 2ns min (This means that $PKTEND$ should not be deasserted before $SLWR\#$)
 Note: $PKTEND$ must be asserted at the same time as $SLWR\#$.

Asynchronous ZLP Write Cycle Timing

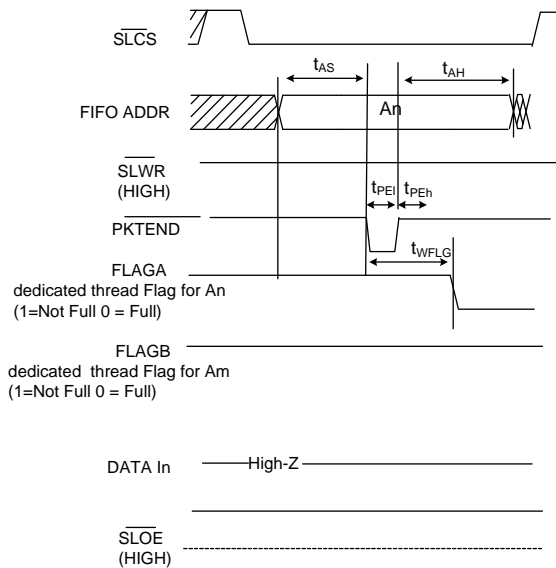

Table 12. Asynchronous Slave FIFO Parameters^[8]

Parameter	Description	Min	Max	Units
tRDI	SLRD# low	20	–	ns
tRDh	SLRD# high	10	–	ns
tAS	Address to SLRD#/SLWR# setup time	7	–	ns
tAH	SLRD#/SLWR#/PKTEND to address hold time	2	–	ns
tRFLG	SLRD# to FLAGS output propagation delay	–	35	ns
tFLG	ADDR to FLAGS output propagation delay		22.5	
tRDO	SLRD# to data valid	–	25	ns
tOE	OE# low to data valid	–	25	ns
tLZ	OE# low to data low-Z	0	–	ns
tOH	SLOE# deassert data output hold	–	22.5	ns
tWRI	SLWR# low	20	–	ns
tWRh	SLWR# high	10	–	ns
tWRS	Data to SLWR# setup time	7	–	ns
tWRH	SLWR# to Data Hold time	2	–	ns
tWFLG	SLWR#/PKTEND to Flags output propagation delay	–	35	ns
tPEI	PKTEND low	20	–	ns
tPEh	PKTEND high	7.5	–	ns
tWRPE	SLWR# deassert to PKTEND deassert	2	–	

Note

8. All parameters guaranteed by design and validated through characterization.

Serial Peripherals Timing

I²C Timing

Figure 16. I²C Timing Definition

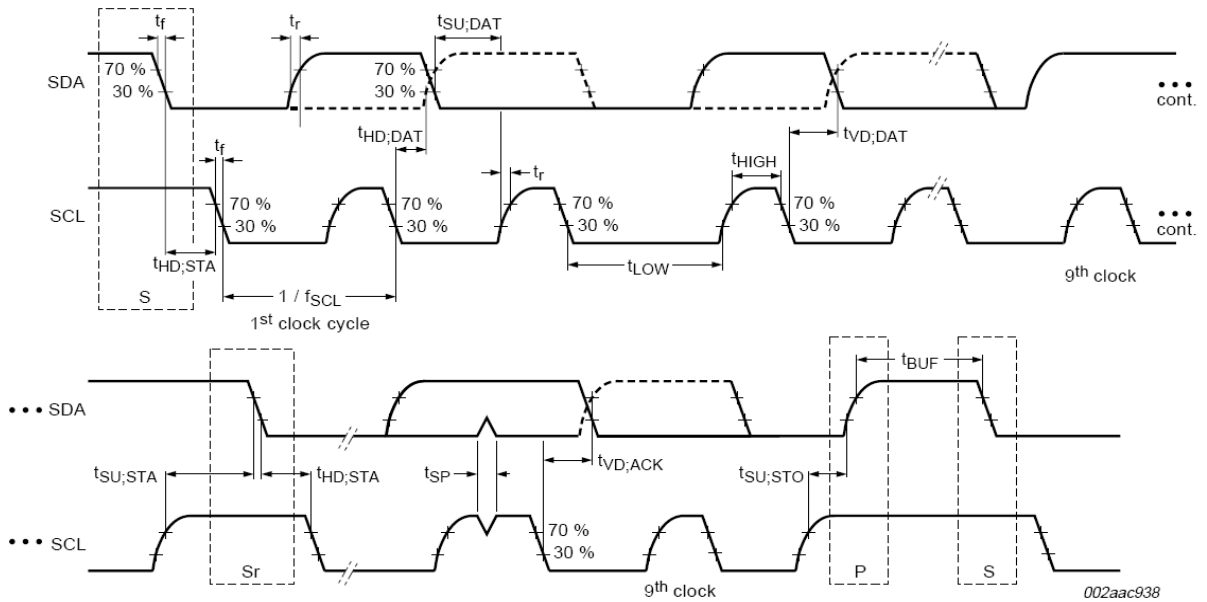

Table 13. I²C Timing Parameters^[9]

Parameter	Description	Min	Max	Units
I²C Standard Mode Parameters				
fSCL	SCL clock frequency	0	100	kHz
tHD:STA	Hold time START condition	4	–	μs
tLOW	LOW period of the SCL	4.7	–	μs
tHIGH	HIGH period of the SCL	4	–	μs
tSU:STA	Setup time for a repeated START condition	4.7	–	μs
tHD:DAT	Data hold time	0	–	μs
tSU:DAT	Data setup time	250	–	ns
tr	Rise time of both SDA and SCL signals	–	1000	ns
tf	Fall time of both SDA and SCL signals	–	300	ns
tSU:STO	Setup time for STOP condition	4	–	μs
tBUF	Bus free time between a STOP and START condition	4.7	–	μs
tVD:DAT	Data valid time	–	3.45	μs
tVD:ACK	Data valid ACK	–	3.45	μs
tSP	Pulse width of spikes that must be suppressed by input filter	n/a	n/a	
I²C Fast Mode Parameters				
fSCL	SCL clock frequency	0	400	kHz
tHD:STA	Hold time START condition	0.6	–	μs
tLOW	LOW period of the SCL	1.3	–	μs
tHIGH	HIGH period of the SCL	0.6	–	μs
tSU:STA	Setup time for a repeated START condition	0.6	–	μs
tHD:DAT	Data hold time	0	–	μs
tSU:DAT	Data setup time	100	–	ns
tr	Rise time of both SDA and SCL signals	–	300	ns
tf	Fall time of both SDA and SCL signals	–	300	ns
tSU:STO	Setup time for STOP condition	0.6	–	μs
tBUF	Bus free time between a STOP and START condition	1.3	–	μs
tVD:DAT	Data valid time	–	0.9	μs
tVD:ACK	Data valid ACK	–	0.9	μs
tSP	Pulse width of spikes that must be suppressed by input filter	0	50	ns

Note

9. All parameters guaranteed by design and validated through characterization.

Table 13. I²C Timing Parameters^[9] (continued)

Parameter	Description	Min	Max	Units
I²C Fast Mode Plus Parameters (Not supported at I2C_VDDQ=1.2 V)				
fSCL	SCL clock frequency	0	1000	kHz
tHD:STA	Hold time START condition	0.26	–	μs
tLOW	LOW period of the SCL	0.5	–	μs
tHIGH	HIGH period of the SCL	0.26	–	μs
tSU:STA	Setup time for a repeated START condition	0.26	–	μs
tHD:DAT	Data hold time	0	–	μs
tSU:DAT	Data setup time	50	–	ns
tr	Rise time of both SDA and SCL signals	–	120	ns
tf	Fall time of both SDA and SCL signals	–	120	ns
tSU:STO	Setup time for STOP condition	0.26	–	μs
tBUF	Bus-free time between a STOP and START condition	0.5	–	μs
tVD:DAT	Data valid time	–	0.45	μs
tVD:ACK	Data valid ACK	–	0.55	μs
tSP	Pulse width of spikes that must be suppressed by input filter	0	50	ns

I²S Timing Diagram

Figure 17. I²S Transmit Cycle

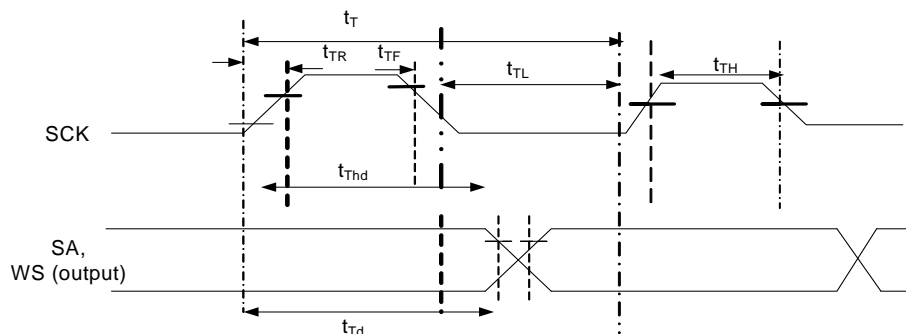

Table 14. I²S Timing Parameters^[10]

Parameter	Description	Min	Max	Units
tT	I ² S transmitter clock cycle	Ttr	–	ns
tTL	I ² S transmitter cycle LOW period	0.35 Ttr	–	ns
tTH	I ² S transmitter cycle HIGH period	0.35 Ttr	–	ns
tTR	I ² S transmitter rise time	–	0.15 Ttr	ns
tTF	I ² S transmitter fall time	–	0.15 Ttr	ns
tThd	I ² S transmitter data hold time	0	–	ns
tTd	I ² S transmitter delay time	–	0.8tT	ns

Note tT is selectable through clock gears. Max Ttr is designed for 96-kHz codec at 32 bits to be 326 ns (3.072 MHz).

Note

10. All parameters guaranteed by design and validated through characterization.

SPI Timing Specification

Figure 18. SPI Timing

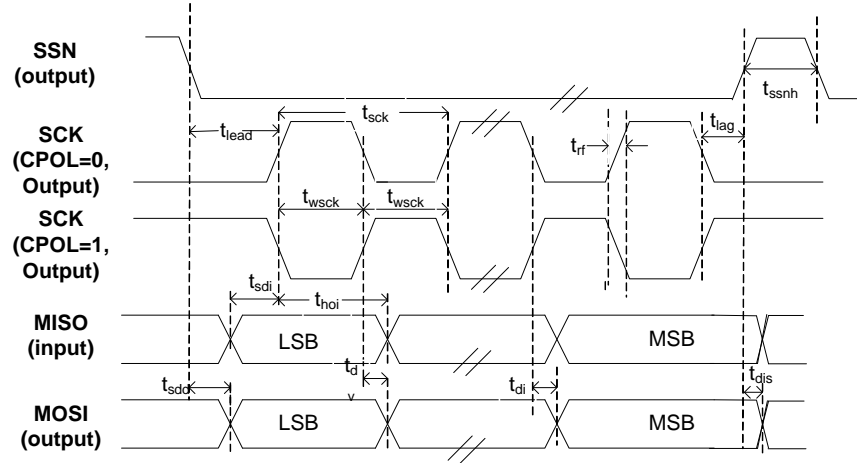

SPI Master Timing for CPHA = 0

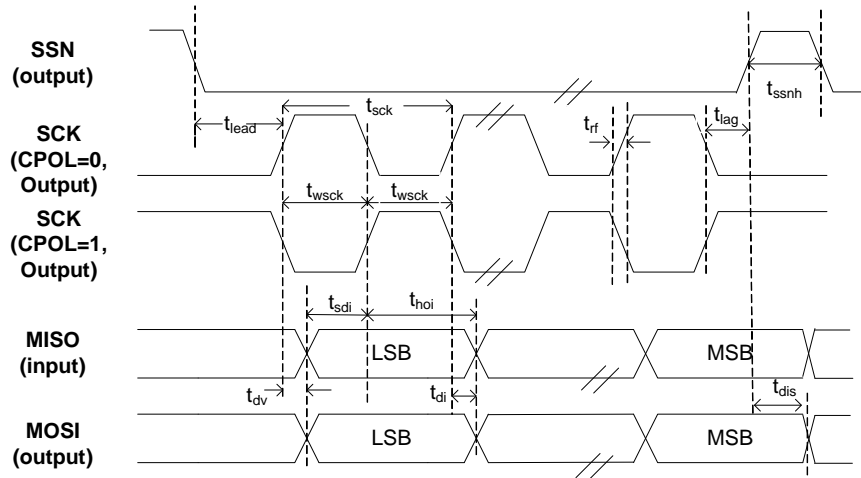

SPI Master Timing for CPHA = 1

Table 15. SPI Timing Parameters^[11]

Parameter	Description	Min	Max	Units
fop	Operating frequency	0	33	MHz
tsck	Cycle time	30	–	ns
twscck	Clock high/low time	13.5	–	ns
tlead	SSN-SCK lead time	$1/2 \text{ tsck}^{[12]} - 5$	$1.5 \text{ tsck}^{[12]} + 5$	ns
tflag	Enable lag time	0.5	$1.5 \text{ tsck}^{[12]} + 5$	ns
trf	Rise/fall time	–	8	ns
tsdd	Output SSN to valid data delay time	–	5	ns
tdv	Output data valid time	–	5	ns
tdi	Output data invalid	0	–	ns
tssnh	Minimum SSN high time	10	–	ns
tsdi	Data setup time input	8	–	ns
thoi	Data hold time input	0	–	ns
tdis	Disable data output on SSN high	0	–	ns

Notes

- 11. All parameters guaranteed by design and validated through characterization.
- 12. Depends on LAG and LEAD setting in the SPI_CONFIG register.

Reset Sequence

FX3's hard reset sequence requirements are specified in this section.

Table 16. Reset and Standby Timing Parameters

Parameter	Definition	Conditions	Min (ms)	Max (ms)
tRPW	Minimum RESET# pulse width	Clock Input	1	–
		Crystal Input	1	–
tRH	Minimum high on RESET#	–	5	–
tRR	Reset recovery time (after which Boot loader begins firmware download)	Clock Input	1	–
		Crystal Input	5	–
tSBY	Time to enter standby/suspend (from the time MAIN_CLOCK_EN/ MAIN_POWER_EN bit is set)	–	–	1
tWU	Time to wakeup from standby	Clock Input	1	–
		Crystal Input	5	–
tWH	Minimum time before Standby/Suspend source may be reasserted	–	5	–

Figure 19. Reset Sequence

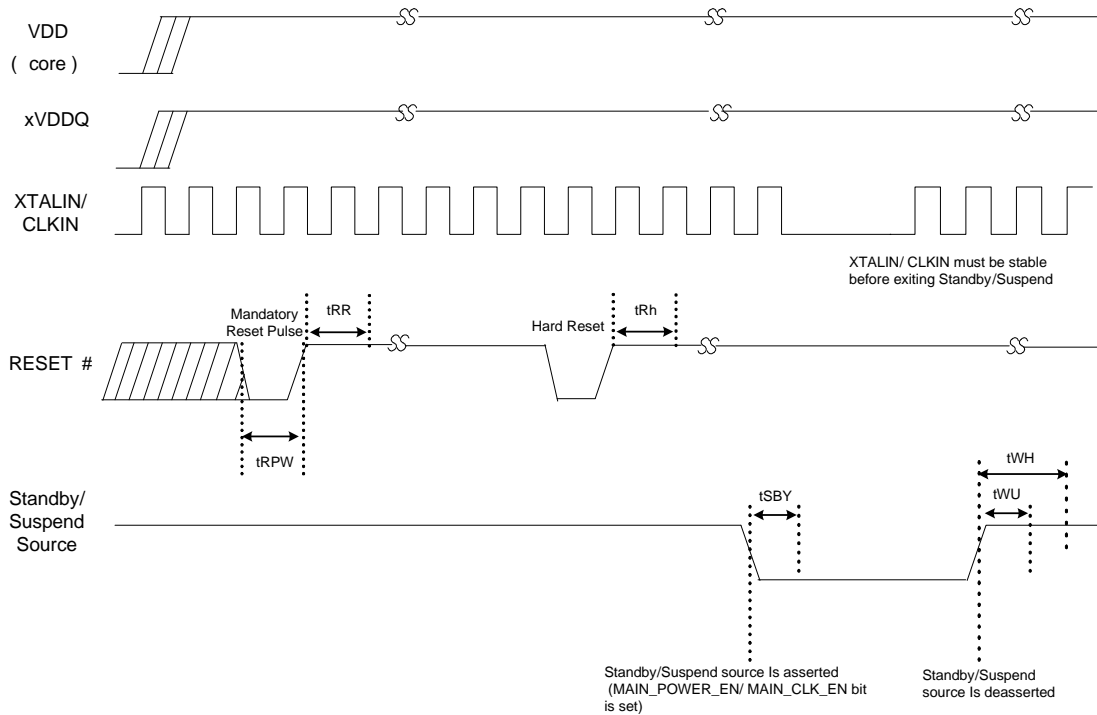

Package Diagram

Figure 20. 121-ball FBGA Package Diagram

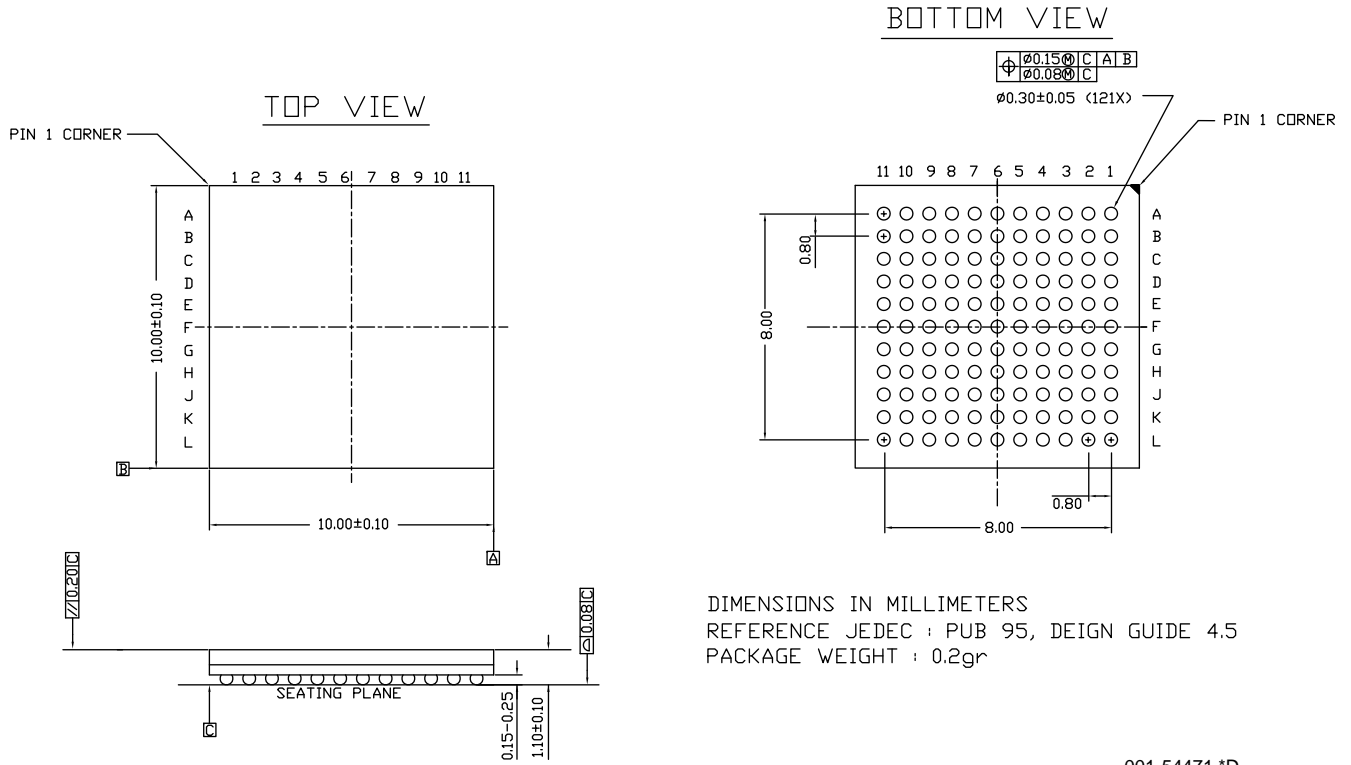

001-54471 *D

Figure 21. 131-ball WLCSP Package Diagram

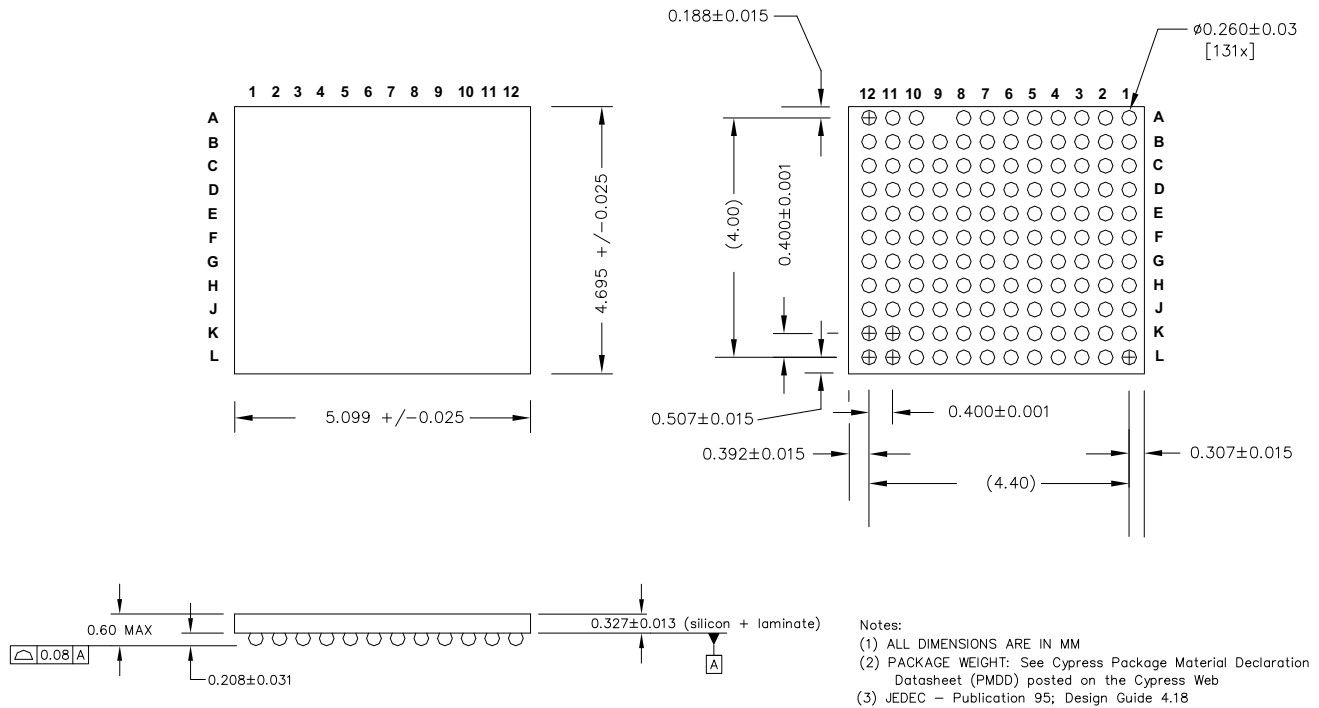

001-62221 *B

Note Underfill is required on the board design. Contact Cypress Applications for details.

Ordering Information

Table 17. Ordering Information

Ordering Code	SRAM (kB)	GPIF II Data Bus Width	Operating Temperature	Package Type
CYUSB3011-BZXC	256	16-bit	0 °C to +70 °C	121-ball BGA
CYUSB3012-BZXC	256	32-bit	0 °C to +70 °C	121-ball BGA
CYUSB3013-BZXC	512	16-bit	0 °C to +70 °C	121-ball BGA
CYUSB3014-BZXC	512	32-bit	0 °C to +70 °C	121-ball BGA
CYUSB3014-BZXI	512	32-bit	-40°C to +85°C	121-ball BGA
CYUSB3014-FBXCT	512	32-bit	0 °C to +70 °C	131-ball CSP
CYUSB3014-FBXIT	512	32-bit	-40 °C to +85 °C	131-ball CSP

Ordering Code Definitions

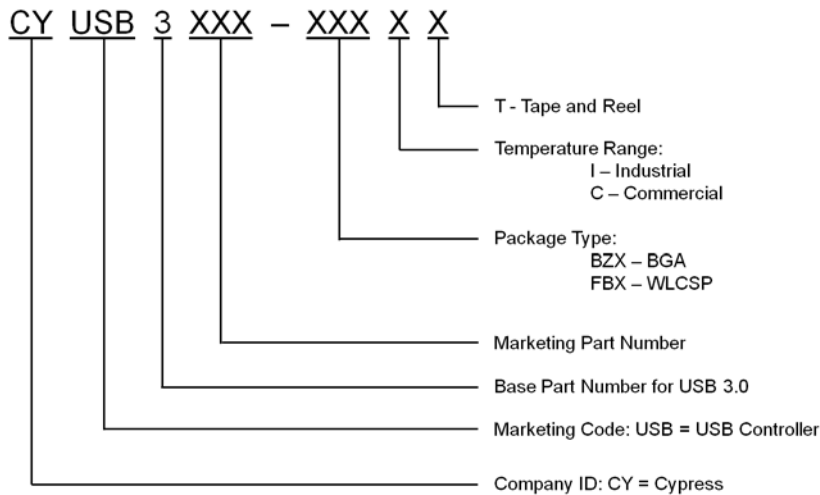

Acronyms

Acronym	Description
DMA	direct memory access
HNP	host negotiation protocol
MMC	multimedia card
MTP	media transfer protocol
PLL	phase locked loop
PMIC	power management IC
SD	secure digital
SD	secure digital
SDIO	secure digital input / output
SLC	single-level cell
SLCS	Slave Chip Select
SLOE	Slave Output Enable
SLRD	Slave Read
SLWR	Slave Write
SPI	serial peripheral interface
SRP	session request protocol
USB	universal serial bus
WLCSP	wafer level chip scale package

Document Conventions

Units of Measure

Symbol	Unit of Measure
°C	degree Celsius
μA	microamperes
μs	microseconds
mA	milliamperes
Mbps	Megabits per second
MBps	Megabytes per second
MHz	mega hertz
ms	milliseconds
ns	nanoseconds
Ω	ohms
pF	pico Farad
V	volts

Document History Page

Document Title: CYUSB301X, EZ-USB [®] FX3: SuperSpeed USB Controller				
Document Number: 001-52136				
Revision	ECN	Orig. of Change	Submission Date	Description of Change
**	2669761	VSO/PYRS	03/06/09	New data sheet
*A	2758370	VSO	09/01/09	<p>Updated the part# from CYX01XXBB to CYUSB3011-BZXI</p> <p>Changed the title from "ADVANCE" to "ADVANCE INFORMATION"</p> <p>In page 1, the second bullet (Flexible Host Interface), add "32-bit, 100 MHz" to first sub bullet.</p> <p>In page 1, changed the second bullet "Flexible Host Interface" to General Programmable Interface".</p> <p>In page 1, the second bullet (Flexible Host Interface), removed "DMA Slave Support" and "MMC Slave support with Pass through Boot" sub bullets.</p> <p>In page 1, third bullet, changed "50 μA with Core Power" to "60 μA with Core Power"</p> <p>In page 1, fifth bullet, added "at 1 MHz"</p> <p>In page 1, seventh bullet, added "up to 4MHz" to UART</p> <p>In page 1, Applications Section, move "Digital Still Cameras" to second line.</p> <p>In page 1, Applications Section, added "Machine Vision" and Industrial Cameras"</p> <p>Added TM to GPIF and FX3.</p> <p>In page 1, updated Logic Block Diagram.</p> <p>In page 2, section of "Functional Overview", updated the whole section.</p> <p>In page 2, removed the section of "Product Interface"</p> <p>In page 2, removed the section of "Processor Interface (P-Port)"</p> <p>In page 2, removed the section of "USB Interface (U-Port)"</p> <p>In page 2, removed the section of "Other Interfaces"</p> <p>In page 2, added a section of "GPIF II"</p> <p>In page 2, added a section of "CPU"</p> <p>In page 2, added a section of "JTAG Interface"</p> <p>In page 2, added a section of "Boot Options"</p> <p>In page 2, added a section of "ReNumeration"</p> <p>In page 2, added a section of "Power"</p> <p>In the section of "Package", replaced "West Bridge USB 3.0 Platform" by FX3.</p> <p>In the section of "Package", added 0.8 mm pitch in front of BGA.</p> <p>Added Pin List (Table 1)</p>
*B	2779196	VSO/PYRS	09/29/09	<p>Features:</p> <p>Added the thrid bullet "Fully accessible 32-bit ARM9 core with 512kB of embedded SRAM"</p> <p>Added the thrid line "EZ USBTM Software and DVK for easy code development"</p> <p>Table 1: Pin 74, corrected to NC - No Connect.</p> <p>Changed title to EZ-USBTM FX3: SuperSpeed USB Controller</p>
*C	2823531	OSG	12/08/09	Added data sheet to the USB 3.0 EROS spec 001-51884. No technical updates.
*D	3080927	OSG	11/08/2010	<p>Changed status from Advance to Preliminary</p> <p>Changed part number from CYUSB3011 to CYUSB3014</p> <p>Added the following sections: Power, Configuration Options, Digital I/Os, System-level ESD, Absolute Maximum Ratings, AC Timing Parameters, Reset Sequence, Package Diagram</p> <p>Added DC Specifications table</p> <p>Updated feature list</p> <p>Updated Pin List</p> <p>Added support for selectable clock input frequencies.</p> <p>Updated block diagram</p> <p>Updated part number</p> <p>Updated package diagram</p>

Document History Page (continued)

Document Title: CYUSB301X, EZ-USB® FX3: SuperSpeed USB Controller				
Document Number: 001-52136				
Revision	ECN	Orig. of Change	Submission Date	Description of Change
*E	3204393	OSG	03/24/2011	Updated Slave FIFO protocol and added ZLP signaling protocol Changed GPIFII asynchronous tDO parameter Changed Async Slave FIFO tOE parameter Changed Async Slave FIFO tRDO parameter Added tCOE parameter to GPIFII Sync mode timing parameters Renamed GPIFII Sync mode tDO to tCO and tDO_ss0 to tCO_ss0 Modified description of GPIFII Sync tCO (previously tDO) parameter Changed tAH(address hold time) parameter in Async Slave FIFO modes to be with respect to rising edge of SLWR#/SLRD# instead of falling edge. Correspondingly, changed the tAH number. Removed 24 bit data bus support for GPIFII.
*F	3219493	OSG	04/07/2011	Minor ECN - Release to web. No content changes.
*G	3235250	GSZ	04/20/2011	Minor updates in Features.
*H	3217917	OSG	04/06/2011	Updated GPIFII Synchronous Timing diagram. Added SPI Boot option. Corrected values of R_USB2 and R_USB3. Corrected TCK and TRST# pull-up/pull-down configuration. Minor updates to block diagrams. Corrected Synchronous Slave FIFO tDH parameter.
*I	3305568	DSG	07/07/2011	Minor ECN - Correct ECN number in revision *F. No content changes.
*J	3369042	OSG	12/06/2011	Changed tWRPE parameter to 2ns Updated tRR and tRPW for crystal input Added clarification regarding I _{OZ} and I _{I_X} Updated Sync SLave FIFO Read timing diagram Updated SPI timing diagram Removed tGRANULARITY parameter Updated I2S Timing diagram and tTd parameter Updated 121-ball FBGA package diagram. Added clarification regarding VCC in DC Specifications table In Power Modes description, stated that VIO1 cannot be turned off at any time if the GPIFII is used in the application Updated Absolute Maximum Ratings Added requirement for by-pass capacitor on U3RX _{VDDQ} and U3TX _{VDDQ} Updated tPEI parameter in Async Slave FIFO timing table Updated Sync Slave FIFO write and read timing diagrams Updated I2C interface tVD:ACK parameter for 1MHz operation Clarified that CTL[15] is not usable as a GPIO Changed datasheet status from Preliminary to Final.
*K	3534275	OSG	02/24/2012	Corrected typo in the block diagram.
*L	3649782	OSG	08/16/2012	Changed part number to CYUSB301X. Added 256 KB range for embedded SRAM. Updated Functional Overview, Other Interfaces, and Clocking sections. Added Pin List for CYUSB3011 and CYUSB3013 parts. Updated Ordering Information with new part numbers.
*M	3848148	OSG	12/20/2012	Updated 121-ball FBGA package diagram to current revision.
*N	4016006	OSG	05/31/2013	Updated Features (Added 131-ball WLCSP under Package option). Updated Pin Configurations (Added FX3 131-ball WLCSP Ball Map (Figure 8)). Updated Pin Description (Updated Table 7). Updated Absolute Maximum Ratings (Included Commercial Temperature Range related information). Updated Operating Conditions (Included Commercial Temperature Range related information). Updated Package Diagram (Added 131-ball WLCSP Package Diagram (Figure 21)). Updated Ordering Information (Updated part numbers).

Sales, Solutions, and Legal Information

Worldwide Sales and Design Support

Cypress maintains a worldwide network of offices, solution centers, manufacturer's representatives, and distributors. To find the office closest to you, visit us at [Cypress Locations](#).

Products

Automotive	cypress.com/go/automotive
Clocks & Buffers	cypress.com/go/clocks
Interface	cypress.com/go/interface
Lighting & Power Control	cypress.com/go/powerpsoc cypress.com/go/plc
Memory	cypress.com/go/memory
PSoC	cypress.com/go/psoc
Touch Sensing	cypress.com/go/touch
USB Controllers	cypress.com/go/USB
Wireless/RF	cypress.com/go/wireless

PSoC Solutions

psoc.cypress.com/solutions
PSoC 1 | PSoC 3 | PSoC 5

© Cypress Semiconductor Corporation, 2009-2013. The information contained herein is subject to change without notice. Cypress Semiconductor Corporation assumes no responsibility for the use of any circuitry other than circuitry embodied in a Cypress product. Nor does it convey or imply any license under patent or other rights. Cypress products are not warranted nor intended to be used for medical, life support, life saving, critical control or safety applications, unless pursuant to an express written agreement with Cypress. Furthermore, Cypress does not authorize its products for use as critical components in life-support systems where a malfunction or failure may reasonably be expected to result in significant injury to the user. The inclusion of Cypress products in life-support systems application implies that the manufacturer assumes all risk of such use and in doing so indemnifies Cypress against all charges.

Any Source Code (software and/or firmware) is owned by Cypress Semiconductor Corporation (Cypress) and is protected by and subject to worldwide patent protection (United States and foreign), United States copyright laws and international treaty provisions. Cypress hereby grants to licensee a personal, non-exclusive, non-transferable license to copy, use, modify, create derivative works of, and compile the Cypress Source Code and derivative works for the sole purpose of creating custom software and or firmware in support of licensee product to be used only in conjunction with a Cypress integrated circuit as specified in the applicable agreement. Any reproduction, modification, translation, compilation, or representation of this Source Code except as specified above is prohibited without the express written permission of Cypress.

Disclaimer: CYPRESS MAKES NO WARRANTY OF ANY KIND, EXPRESS OR IMPLIED, WITH REGARD TO THIS MATERIAL, INCLUDING, BUT NOT LIMITED TO, THE IMPLIED WARRANTIES OF MERCHANTABILITY AND FITNESS FOR A PARTICULAR PURPOSE. Cypress reserves the right to make changes without further notice to the materials described herein. Cypress does not assume any liability arising out of the application or use of any product or circuit described herein. Cypress does not authorize its products for use as critical components in life-support systems where a malfunction or failure may reasonably be expected to result in significant injury to the user. The inclusion of Cypress' product in a life-support systems application implies that the manufacturer assumes all risk of such use and in doing so indemnifies Cypress against all charges.

Use may be limited by and subject to the applicable Cypress software license agreement.