

# MC5728V Mini Card

## Product Specification



2111350  
Rev 1.2

## Important Notice

Because of the nature of wireless communications, transmission and reception of data can never be guaranteed. Data may be delayed, corrupted (i.e., have errors) or be totally lost. Although significant delays or losses of data are rare when wireless devices such as the Sierra Wireless modem are used in a normal manner with a well-constructed network, the Sierra Wireless modem should not be used in situations where failure to transmit or receive data could result in damage of any kind to the user or any other party, including but not limited to personal injury, death, or loss of property. Sierra Wireless accepts no responsibility for damages of any kind resulting from delays or errors in data transmitted or received using the Sierra Wireless modem, or for failure of the Sierra Wireless modem to transmit or receive such data.

## Safety and Hazards

Do not operate the Sierra Wireless modem in areas where blasting is in progress, where explosive atmospheres may be present, near medical equipment, near life support equipment, or any equipment which may be susceptible to any form of radio interference. In such areas, the Sierra Wireless modem **MUST BE POWERED OFF**. The Sierra Wireless modem can transmit signals that could interfere with this equipment.

Do not operate the Sierra Wireless modem in any aircraft, whether the aircraft is on the ground or in flight. In aircraft, the Sierra Wireless modem **MUST BE POWERED OFF**. When operating, the Sierra Wireless modem can transmit signals that could interfere with various onboard systems.

The driver or operator of any vehicle should not operate the Sierra Wireless modem while in control of a vehicle. Doing so will detract from the driver or operator's control and operation of that vehicle. In some states and provinces, operating such communications devices while in control of a vehicle is an offence.

---

**Note:** Some airlines may permit the use of cellular phones while the aircraft is on the ground and the door is open. Sierra Wireless modems may be used at this time.

---

## Limitation of Liability

The information in this manual is subject to change without notice and does not represent a commitment on the part of Sierra Wireless or its affiliates. SIERRA WIRELESS AND ITS AFFILIATES SPECIFICALLY DISCLAIM LIABILITY FOR ANY AND ALL DIRECT, INDIRECT, SPECIAL, GENERAL, INCIDENTAL, CONSEQUENTIAL, PUNITIVE OR EXEMPLARY DAMAGES INCLUDING, BUT NOT LIMITED TO, LOSS OF PROFITS OR REVENUE OR ANTICIPATED PROFITS OR REVENUE ARISING OUT OF THE USE OR INABILITY TO USE ANY SIERRA WIRELESS PRODUCT, EVEN IF SIERRA WIRELESS AND/OR ITS AFFILIATES HAS BEEN ADVISED OF THE POSSIBILITY OF SUCH DAMAGES OR THEY ARE FORESEEABLE OR FOR CLAIMS BY ANY THIRD PARTY.

Notwithstanding the foregoing, in no event shall Sierra Wireless and/or its affiliates aggregate liability arising under or in connection with the Sierra Wireless product, regardless of the number of events, occurrences, or claims giving rise to liability, be in excess of the price paid by the purchaser for the Sierra Wireless product.

## Patents

Portions of this product are covered by some or all of the following US patents:

5,515,013	5,629,960	5,845,216	5,847,553	5,878,234
5,890,057	5,929,815	6,169,884	6,191,741	6,199,168
6,339,405	6,359,591	6,400,336	6,516,204	6,561,851
6,643,501	6,653,979	6,697,030	6,785,830	6,845,249
6,847,830	6,876,697	6,879,585	6,886,049	6,968,171
6,985,757	7,023,878	7,145,267	7,200,512	7,287,162
7,295,171	D442,170	D459,303	D559,256	D560,911

and other patents pending.

This product includes technology licensed from QUALCOMM® 3G.

Manufactured or sold by Sierra Wireless Inc., its Affiliates, or its Licensees under one or more patents licensed from InterDigital Group.

## Trademarks

Heart of the Wireless Machine is a registered trademark of Sierra Wireless. Watcher is a trademark of Sierra Wireless, registered in the European Community. Sierra Wireless, the Sierra Wireless logo, the red wave design, and EMConnect are trademarks of Sierra Wireless.

Windows® is a registered trademark of Microsoft Corporation. QUALCOMM® is a registered trademark of QUALCOMM Incorporated. gpsOne is a trademark of QUALCOMM Incorporated.

InstallShield® is a registered trademark of InstallShield Software Corporation.

cdma2000® is a registered trademark of the Telecommunications Industry Association (TIA–USA).

Other trademarks are the property of the respective owners.

## Contact information

Sales Desk	Phone:	1-604-232-1488
	Hours:	8:00 am to 5:00 pm Pacific Time
	e-mail:	<a href="mailto:sales@sierrawireless.com">sales@sierrawireless.com</a>
Technical Support:	Included with the Software Development Kit, you receive five hours of tier 3 engineering integration support. Follow the e-mail instructions you received on how to access the OEM Customer Support web site. For details, contact your account manager, or the Sierra Wireless sales desk.	
Post:	Sierra Wireless 13811 Wireless Way Richmond, BC Canada V6V 3A4	
Fax:	1-604-231-1109	
Web:	<a href="http://www.sierrawireless.com">www.sierrawireless.com</a>	

For up-to-date product descriptions, documentation, application notes, [firmware](#) upgrades, troubleshooting tips, and press releases, consult our website: [www.sierrawireless.com](http://www.sierrawireless.com).

# Table of Contents

<b>Introduction .....</b>	<b>11</b>
Revision history .....	11
Specifications at a glance .....	12
Physical features .....	12
Electrical features.....	12
Environmental features.....	13
RF features.....	13
Application interface features .....	13
EMConnect features.....	14
Voice features .....	14
Packet mode features .....	14
IS-95 circuit-switched features .....	15
Short Message Service (SMS) features .....	15
Support features.....	15
Supporting documents .....	15
Accessories available.....	15
Ordering information .....	16
<b>CDMA Overview .....</b>	<b>17</b>
Fundamental and supplemental channels .....	17
1X and IS-95A .....	17
1xEV-DO.....	18
<b>Standards Compliance .....</b>	<b>20</b>
General compliance.....	20
Mobile station class .....	20
Protocol revision support.....	20
TIA/EIA-95B.....	21
TIA/EIA/IS-2000.....	21
Radio configurations.....	21
Release A feature support.....	22
TIA/EIA/IS-856 (1xEV-DO) .....	23

CDMA data services .....	24
CDMA voice services.....	25
CDMA Short Message Service (SMS) .....	25
Over-The-Air Service Provisioning (OTASP) .....	26
IS-683 features.....	26
Internet Over The Air (IOTA) features .....	26
Position location.....	27
Additional standards .....	28
CDMA certification requirements .....	28
CDMA parametric performance.....	28
Interoperability.....	29
FCC and Industry Canada type acceptance.....	29
<b>Electrical Specifications.....</b>	<b>30</b>
Host interface.....	31
Pin assignments.....	31
Host interface descriptions .....	33
Power supply.....	34
USB interface .....	34
Control interface .....	34
Digital interface.....	35
Analog interface .....	37
PCM interface.....	39
RF specifications .....	43
GPS specifications .....	46
GPS antenna specifications .....	46
Power consumption .....	47
<b>Software Interface .....</b>	<b>49</b>
Physical interface options .....	49
Data channel interface.....	49
Control channel interface .....	50
Support tools.....	51
Other features.....	51
Manufacturing test support.....	51

Memory requirements ..... 51

**Mechanical and Environmental Specifications ..... 52**

    Labeling ..... 54

**Additional Requirements..... 56**

    Regulatory approvals..... 56

        FCC ..... 56

        Assistance provided by Sierra Wireless ..... 57

        CDG ..... 58

    Integration requirements ..... 58

**Appendix A: Service Option Support ..... 60**

**Appendix B: References..... 61**

    Sierra Wireless documents ..... 61

    TIA/EIA standards..... 61

    CDG standards ..... 63

    Agency standards ..... 63

    Other standards ..... 64

**Appendix C: Acronyms ..... 65**

**Index..... 68**

# List of tables

Table 1: Revision history.....	11
Table 2: Comparison of data and voice characteristics.....	18
Table 3: Band and power class features.....	20
Table 4: Support for P_REV 5 features.....	21
Table 5: Channel and radio configuration support.....	22
Table 6: Support for P_REV 6 features.....	22
Table 7: Support for P_REV 7 features.....	23
Table 8: Support for 1xEV-DO.....	23
Table 9: IS-707-A data features.....	24
Table 10: Data features supported.....	24
Table 11: SMS features.....	25
Table 12: OTASP/OTAPA features.....	26
Table 13: IOTA features.....	27
Table 14: Position location features.....	27
Table 15: US and Industry Canada compliance requirements .....	29
Table 16: Connector pin assignments.....	31
Table 17: Power and ground specifications.....	34
Table 18: USB interface.....	34
Table 19: MC5728V Mini Card control signals.....	34
Table 20: Control signal DC electrical specifications.....	35
Table 21: MC5728V Mini Card digital signals.....	35
Table 22: Digital signal DC electrical specifications.....	36
Table 23: MC5728V Mini Card analog signals.....	37
Table 24: Recommended operating conditions.....	37
Table 25: Audio transmit path performance characteristics for MIC1_P/MIC1_N.....	38
Table 26: Audio receive path performance characteristics for SPK1_P/SPK1_N.....	39
Table 27: PCM digital audio interface connections.....	40
Table 28: PCM_CODEC timing parameters.....	41



Table 29: AUX\_CODEC timing parameters ..... 43

Table 30: Supported bands..... 44

Table 31: Main antenna specifications ..... 44

Table 32: RF performance ..... 45

Table 33: Diversity antenna specifications ..... 45

Table 34: GPS sensitivity ..... 45

Table 35: GPS specifications ..... 46

Table 36: GPS antenna specifications ..... 46

Table 37: DC power consumption (+3.3V) ..... 47

Table 38: CNS message categories..... 50

Table 39: Mechanical and environmental specifications ..... 52

Table 40: Service Option support..... 60

Table 41: Acronyms ..... 65

## List of figures

Figure 1: MC5728V system block diagram .....	31
Figure 2: Timing diagram: PCM_SYNC .....	40
Figure 3: Timing diagram: PCM_CODEEC to QSC6085.....	40
Figure 4: Timing diagram: QSC6085 to PCM_CODEEC.....	41
Figure 5: Timing diagram: AUX_PCM_SYNC .....	42
Figure 6: Timing diagram: AUX_PCM_CODEEC to QSC6085 .....	42
Figure 7: Timing diagram: QSC6085 to AUX_PCM_CODEEC .....	42
Figure 8: Location of connectors .....	44
Figure 9: Top and bottom view.....	53
Figure 10: Dimensioned view.....	54

# Introduction

The Sierra Wireless MC5728V PCI-Express Mini Card is a compact, light-weight, standards-based, wireless data modem that provides voice features, and [CDMA](#) and [1xEV-DO](#) wireless data connectivity for portable and handheld computers, point-of-sale devices, telemetry products and other machine-to-machine and vertical applications. The MC5728V Mini Card is part of a family of embedded wireless engines spanning a number of air interface technologies and wide area networking protocols. It has a dual-band diversity radio supporting the 800 MHz cellular and 1900 MHz [PCS](#) bands as well as [GPS](#) frequency band. The modem is based on QUALCOMM's QSC6085 integrated processor. The purpose of this document is to describe the features and specifications of the modem and to provide our [OEM](#) partners/customers with the information required to integrate the MC5728V Mini Card into their products. Application and hardware interface requirements are discussed at a high level only; for more detail, see the Sierra Wireless technical references available in the *Mini Card Hardware Integration Guide* and the Universal Development Kit.

---

**Note:** You can view this guide online or print it to keep on hand. If you're viewing it online, simply click a topic in the [Table of Contents](#), or any page reference or section reference. (Most text that is blue is a clickable link.) The PDF automatically displays the appropriate page.

---

## Revision history

**Table 1: Revision history**

Version	Summary of changes
<b>1.0 Mar 09</b>	Initial release
<b>1.1 May 09</b>	<p>Removed references to I<sup>2</sup>C.</p> <p>Added "<a href="#">EMConnect features</a>" (page 14).</p> <p>Added some categories to <a href="#">Table 38</a> "CNS message categories" (page 50).</p> <p>Version of QUALCOMM software is AMSS6085 (not AMSS6800).</p>

Version	Summary of changes
1.2 Aug 09	<p>Added <a href="#">Table 24</a> on page 37.</p> <p>Changes to:</p> <ul style="list-style-type: none"> <li>• Current specifications (“<a href="#">Electrical features</a>” on page 12; <a href="#">Table 37</a> on page 47)</li> <li>• Pinout (<a href="#">Table 16</a> on page 31): pins 24, 30, 32, 44, 46, 48, 49, 51</li> <li>• <a href="#">Table 17</a> (page 34): pin 24 added</li> <li>• <a href="#">Table 19</a> (page 34): “Type” for pin 32</li> <li>• <a href="#">Table 21</a> (page 35): “Type” for pins 6, 16, 28, 47, 48, 49, 51</li> <li>• <a href="#">Table 25</a> (page 38)</li> <li>• <a href="#">Table 26</a> (page 39)</li> <li>• <a href="#">Table 27</a> (page 40): “Type” for pins 45, 49, 51</li> <li>• <a href="#">Table 39</a> (page 52): ESD, non-operational.</li> <li>• Figure 9 “<a href="#">Top and bottom view</a>” (page 53)</li> <li>• Figure 10 “<a href="#">Dimensioned view</a>” (page 54)</li> <li>• Title page (replaced drawing with a photo)</li> <li>• Definitions of <a href="#">PU</a> and <a href="#">PD</a>: removed “Input” (page 33)</li> </ul>

## Specifications at a glance

This section outlines the critical high-level features of the Sierra Wireless MC5728V PCI-Express Mini Card. More detailed specifications are provided in following chapters.

### Physical features

- Small PCI-Express Mini Card standards-based form factor. Adheres to Rev 1.2 of the [PCI Express Mini Card Specification](#)
- Two U.FL [RF](#) connector jacks

### Electrical features

The MC5728V Mini Card has one supply voltage:

- VCC—Min 3.0 V, Max 3.6 V

Typical DC power consumption:

- Talk current: 185 mA—248 mA
- Standby current: 1.9 mA—5.6 mA
- Data current: 300 mA—360 mA

The MC5728V Mini Card is self-shielded; no additional shielding is required.

## Environmental features

Temperature operating range:

- IS-98D compliance: -30 to +60 degrees C
- Reduced RF performance: +60 to +75 degrees C

## RF features

- Dual-band support for both the 800 MHz cellular and 1.9 GHz PCS bands
- Receive diversity support for the 800 MHz cellular and 1.9 GHz PCS bands
- Adheres to CDMA authentication as specified in CDMA 1X
- Support for IS-95A/B and CDMA 1X Release 0/A
- Support for IS-856 1xEV-DO Revision A
- Support for gpsOne™ and stand-alone GPS

## Application interface features

- NDIS supported for Windows Vista, Windows XP, and Windows 2000 platforms
- USB supporting multiple logical channels over the USB MUX protocol
- USB selective suspend supported for maximum power savings
- Wakeup Enable—the modem can be set to wake the host device upon ring, restoration of radio coverage, and/or receipt of SMS
- Up to two UART ports, and one USB port
- AT command interface
- Sierra Wireless proprietary Control and Status (CnS) language interface
- Available Software Development Kit (SDK) including an Application Program Interface (API) for Windows-based applications

## EMConnect features

The MC5728V Mini Card supports EMConnect™—a robust set of firmware features that enables original equipment manufacturers (OEMs) to reduce their development time, platform costs and dependence on host processors.

The MC5728V Mini Card supports these EMConnect features:

- Enhanced serial (UART) interface
- PAD (Packet Assembler Dis-assembler)
- Connection Watchdog to ensure connectivity
- Enhanced GPIO
- Modem configuration persistence

For more information on EMConnect, see the *EMConnect Guide* (document 2131177).

## Voice features

- Differential line-level mic input and speaker output
- [PCM interface](#)
- Echo cancellation

The MC5728V Mini Card has internal [IS-127](#) and [IS-733](#) vocoders and supports:

- Call origination
- Silent retry call origination protocol
- Echo cancellation
- E911
- Incoming call notification

For the supported service options, see [Table 40](#) on page 60.

## Packet mode features

- IS-2000 data rates up to 153<sup>1</sup> [kbps](#), simultaneous forward and reverse channel.
- [IS-856 \(1xEV-DO Rev. A\)](#) data rates up to 3.1 [Mbps](#) forward channel and 1.8 Mbps reverse channel.

---

<sup>1</sup> Data rate supported depends on network implementation.

## **IS-95 circuit-switched features**

- V.34 data rates to 14.4 kbps
- G3 facsimile receive and transmit
- Quick Net Connect (QNC) support

## **Short Message Service (SMS) features**

- Send and receive
- Notification of new messages

## **Support features**

The MC5728V Mini Card offers:

- Standard 1-year warranty
- Extended warranties of 1 or 2 additional years available
- Enabling software for Windows Vista, Windows XP, and Windows 2000.
- Over-The-Air-Service Provisioning (OTASP)
- Support for gpsOne and Location Based Services
- Wireless Disable control function

## **Supporting documents**

See “[Appendix B: References](#)” on page 61.

## **Accessories available**

The MC5728V MiniCard Development Kit (part number 6000270) includes:

- Embedded Modem Interface Kit
- Power supply
- Antennas (main and diversity)
- Documentation suite
- Initial allotment of support hours
- [USB](#) cable
- Headset

## Ordering information

All orders can be made by contacting the Sierra Wireless Sales Desk at +1 (604) 232-1488 between 8 AM and 5 PM Pacific Time.



# CDMA Overview

The market has been demanding faster wireless data services, and the industry has been developing third generation wireless systems to address this demand. 3G systems are intended to provide users with high-speed data services for improved performance of wireless data applications, enhanced multimedia content delivery, and to improve network capacity to support additional subscribers. The International Telecommunications Union (ITU) initiated the IMT2000 program to develop standards for 3G systems, and completed them in late 1999. The IMT2000 program defined several standards; **CDMA 1X** is one of them. For additional information on the IMT2000 program visit the ITU web site at [www.itu.int/imt](http://www.itu.int/imt). For additional information on CDMA in general, consult the CDMA Development Group web site at [www.cdg.org](http://www.cdg.org).

## Fundamental and supplemental channels

CDMA **1X** achieves higher speeds for packet services by making use of supplemental channels to provide additional bandwidth.

The modem first connects in a circuit-switched fashion, using a fundamental channel. When there is a requirement for a burst of packet data at high speed, the modem can request a supplemental channel to carry the traffic. When the burst is finished, the supplemental channel is released for other network users.

The network manages allocation of supplemental channels. In particularly busy networks, this means that throughput could be reduced when many users request access to a supplemental channel resource. If a supplemental channel is unavailable, the modem continues to move traffic over the fundamental channel.

## 1X and IS-95A

The type of data connection made at any given time depends on the services available from the carrier in the given coverage area. If **1X** packet services are not available, the modem connects using circuit-switched data over IS-95A technology. The modem automatically selects the fastest connection mode available when a data call is connecting.

When roaming, the modem **does not** automatically change connection modes. If the modem connects using 1X and then roams outside of the packet service area, the connection is dropped. To resume data communication, a new connection using IS-95A has to be created. Similarly, an IS-95A call established in one area does not automatically transition to 1X when the unit enters the 3G coverage area.

## 1xEV-DO

1xEV-DO is backwards compatible to both 1X and IS-95A/B standards. However, 1xEV-DO represents an evolutionary enhancement, specifically designed and optimized for high-speed wireless data access. This was driven by fact that voice and data traffic have very different fundamental characteristics, as shown in the following table.

**Table 2: Comparison of data and voice characteristics**

Characteristic	Data	Voice
High-bandwidth	Suited to higher bandwidths (depending on the application)	Not required
Tolerance to latency	High	Low
Traffic characteristics	Bursty	Relatively symmetric, with uniform transmission of information
Quick allocation and de-allocation of network resources	Required	Resources are reserved until a call is terminated

To optimize for data, there are some fundamental characteristics and differences between 1X and 1xEV-DO, including:

- The network has dedicated spectrum (1.25 MHz) for data traffic using 1xEV-DO standard, so resources don't compete with 1X data/voice (hybrid mode used to monitor 1X carriers)
- BTS always transmits at maximum available power
- Each user receives data from only one base station at a time (no forward link soft handoff)
- 1xEV-DO lets each user use 100% of available resources, while dynamically allocating time resources among users for maximum efficiency
- 1xEV-DO uses time-division multiplexing of users on forward link (slots assigned for packet transmission)

- Forward link supports higher order modulation (QPSK, 8-PSK and 16-QAM)
- Reverse link (1xEV-DO Revision A) supports higher order modulation (8-PSK)
- Mobile supports dynamic channel estimation using measured S/N to set the highest rate it can decode (uses Data Rate Control channel to communicate to network access point)
- Mobiles can support Rx diversity for S/N enhancements particularly in multi-path/fading environments

# Standards Compliance

This section describes the compliance of the MC5728V Mini Card to the standards described in “[Appendix B: References](#)” on page 61. Many of these features require the support of the host device for full compliance. These cases are noted.

“[Appendix A: Service Option Support](#)” on page 60 summarizes the service options supported by the MC5728V Mini Card.

## General compliance

### Mobile station class

The output power and band class features of the MC5728V Mini Card are summarized in Table 3.

**Table 3: Band and power class features**

Band Class	Mobile Station Class	Supported?
0 (North American Cellular) <sup>2</sup>	Class III	Yes
1 (North American PCS) <sup>3</sup>	Class II	Yes
2 (TACS)	N/A	No
3 (JTACS)	N/A	No
4 (Korean PCS)	N/A	No
5 (NMT 450)	N/A	No
6 (IMT-2000)	N/A	No

### Protocol revision support

The MC5728V Mini Card supports all protocol revisions through P\_REV 7. Detailed protocol revision feature compliance is described in the next two sections.

<sup>2</sup> Band Class 0 also supports cellular bands in other regions including Asia Pacific, Latin America and the Middle East.

<sup>3</sup> Band Class 1 also supports PCS bands in other regions including Asia Pacific and Latin America.

## TIA/EIA-95B

The MC5728V Mini Card is compliant with [TIA/EIA-95-B](#), including all protocol revisions through P\_REV 4. Feature support for P\_REV 5 is defined in Table 4.

**Table 4: Support for P\_REV 5 features**

Feature	Supported?
Access Entry Handoff	Yes
Access Probe Handoff	Yes
Channel Assignment into Soft Handoff	Yes
Mobile Assisted Hard Handoff	Yes
Network Directed System Selection	Yes
Calling Name Presentation (CNAP)	Yes <sup>4</sup>
Priority Access and Channel Assignment (PACA)	No
Power-Up Function (PUF)	No
AMPS Improvements (IS-553-A)	N/A
Supplemental Code Channels (MDR)	Yes <sup>5</sup>
Hopping Pilot Beacon	No
IS-95B Wireless Local Loop (WLL) Features	No

## TIA/EIA/IS-2000

The MC5728V Mini Card support for [TIA/EIA/IS-2000](#) features is defined by the capabilities of the QUALCOMM QSC6085 hardware and AMSS6085 software.

### Radio configurations

The MC5728V Mini Card supports all mandatory radio configurations. Detailed channel and radio configuration support is shown in [Table 5](#) on page 22.

Table 5 also outlines the data rates supported by each radio configuration. The maximum data rate supported by 1X is 153 **kbps** simultaneously on the forward and reverse link. The maximum data rate supported for [IS-856 \(1xEV-DO Rev. A\)](#) is 3.1 **Mbps** on the forward link and 1.8 Mbps on the reverse link.

<sup>4</sup>Host support is required for this feature

<sup>5</sup>Only F-SCCH is supported. Up to seven F-SCCH supported.

**Table 5: Channel and radio configuration support<sup>6</sup>**

Feature	Supported	Simultaneous data rate (kbps)	
		Forward link	Reverse link
<b>Quick Paging Channel (F-QPCH)</b>	Yes		
<b>Fundamental Channel (FCH)</b>			
Rate Set 1 RCs (fwd: 1,3,4; rev: 1,3)	Yes	9.6	9.6
Rate Set 2 RCs (fwd: 2,5; rev: 2,4)	Yes	14.4	14.4
<b>Supplemental Channel (SCH)</b>			
Rate Set 1 RCs (fwd: 3,4; rev: 3)	Yes	9.6/19.2/38.4/76.8/153.6/307.2	9.6/19.2/38.4/76.8/153.6/307.2
Rate Set 2 RCs (fwd: 5; rev: 4)	Yes	14.4/28.8/57.6/115.2/230.4	14.4/28.8/57.6/115.2/230.4
<b>Dedicated Control Channel (DCCH)<sup>7</sup></b>			
Rate Set 1 RCs (fwd: 3,4; rev: 3)	Yes	9.6	9.6
Rate Set 2 RCs (fwd: 5; rev: 4)	Yes	14.4	14.4
<b>Reverse Pilot Channel (R-PICH)</b>	Yes		

### Release A feature support

The MC5728V Mini Card supports all mandatory P\_REV 6 features. Additional support for P\_REV 6 features is described in the following table. The MC5728V Mini Card provides support for P\_REV 7 Release A features as supported by QUALCOMM QSC6085 software. Specific features are to be determined. Note that not all Release A features may be supported by carriers or network equipment.

**Table 6: Support for P\_REV 6 features**

Optional P_REV 6 feature	Supported?
Simultaneous Maximum Data rates on Forward and Reverse Channels	Yes
Quasi Orthogonal Functions (QOF)	Yes
Turbo encoding/decoding	Yes
Quick Paging Channel	Yes

<sup>6</sup> Support of maximum data rates is dependant on MSM supplier software, memory speed grade availability and network implementation.

<sup>7</sup> 20 ms frames only

Optional P_REV 6 feature	Supported?
Slotted Mode Timer	Yes
Orthogonal Transmit Diversity (OTD)	Yes
Reverse Pilot Gating	Yes
1/8 Rate Traffic Channel Gating	Yes
Mobile Assisted Burst Operation (MABO)	No
Traffic Channel Control Hold	Yes
Short Data Bursts	Yes
5 ms, 10 ms Frame sizes	No

**Table 7: Support for P\_REV 7 features**

P_REV 7 features supported	Supported?
Simultaneous Voice and Data	Yes
Simultaneous forward link and reverse link up to 153 kbps	Yes
Turbo and convolutional encoding/decoding	Yes
Enhanced Access Channel	Yes
Broadcast Control Channel	Yes
Forward Common Control Channel	Yes
Reverse Common Control Channel	Yes
Quality of Service Negotiation	Yes

## TIA/EIA/IS-856 (1xEV-DO)

The MC5728V Mini Card supports TIA/EIA/IS-856-A (1xEV-DO) features as defined by the capabilities of the QUALCOMM QSC6085 hardware and AMSS6085 software.

**Table 8: Support for 1xEV-DO**

Feature	Supported?
Air Interface as defined by IS-856	Yes
Packet Data Service in Relay Mode	Yes
Support for Test Application Specification (IS-890)	Yes
Dual RF Receive Diversity	Yes
1X/1xEV Hybrid Terminal Operation	Yes
Connected State Off-Frequency Neighbor Search	Yes
Slotted Mode (Sleep) Operation	Yes
High Speed Broadcast Services (HSBS)	Yes
Handoff Between IS-2000 and IS-856 Systems	Yes

Feature	Supported?
Quality of Service (QoS) Enhancements	Yes
Data rates up to 3.1 Mbps on the forward channel and 1.8 Mbps on the reverse channel.	Yes

## CDMA data services

The MC5728V Mini Card supports the data features of [IS-707-A](#) as shown in Table 9. Actual data speeds supported by the MC5728V Mini Card are shown in [Table 5](#) on page 22. Table 9 outlines support for additional data features that are not part of IS-707-A.

**Table 9: IS-707-A data features**

CDMA Data Service	IS-707-A section	Supported?
<a href="#">RLP</a>	IS-707.2	Yes <sup>8</sup>
<a href="#">AT</a> Command Set	IS-707.3	Yes
Asynchronous Data and Fax at 9.6 kbps and 14.4 kbps	IS-707.4	Yes
Packet Data Service	IS-707.5	Yes
STU-III	IS-707.6	No
Analog Fax	IS-707.7	No
Radio Link Protocol Type 2 (RLP2)	IS-707.8	Yes
High Speed Packet Data (MDR - Medium Data Rate)	IS-707.9	Yes
Radio Link Protocol Type 3 (RLP3)	IS-707.10	Yes
CDMA High Speed Packet Data	IS-707.12	Yes

**Table 10: Data features supported**

Feature	Supported?
Quick Net Connect	Yes
Pre-arrangement for incoming Async data or fax	Yes
In-Band <a href="#">DCE</a> Control ( <a href="#">TIA/EIA-617</a> )	Yes
Facsimile Digital Interfaces ( <a href="#">TIA/EIA/IS-134</a> )	Yes
Asynchronous facsimile <a href="#">DCE</a> Control Standard ( <a href="#">TIA/EIA-592</a> )	Yes
Simple IP	Yes
Mobile IP ( <a href="#">TIA/EIA/IS-835-A</a> )	Yes

<sup>8</sup>Encrypted mode and non-transparent modes are NOT supported.



## CDMA voice services

The MC5728V Mini Card supports EVRC and 13QCELP vocoders and complies with the following Voice Service Option standards:

- [TIA/EIA/IS-733-1](#): 13QCELP Vocoder Specification
- [TIA/EIA/IS-736](#): 13QCELP Minimum Performance Requirements
- [TIA/EIA/IS-127-2](#): EVRC Vocoder Specification
- [TIA/EIA/IS-718](#): EVRC Minimum Performance Requirements

The MC5728V Mini Card supports TTY/TDD compatibility through the microphone/speaker connections.

## CDMA Short Message Service (SMS)

Table 11 summarizes compliance of the MC5728V Mini Card with the SMS features per [TIA/EIA-637-B](#). Note that not all of these features are available on all carrier networks, and host device support is required for compliance with these features. The MC5728V Mini Card also complies with specific carrier requirements for SMS as defined by each CDMA carrier.

**Table 11: SMS features**

Feature	Supported?
Mobile Terminated SMS	Yes
Mobile Originated SMS	Yes
Point-to-Point Messaging	Yes
Broadcast Messaging	Yes
Acknowledge Messaging	Yes
Analog Mode SMS	No
Wireless Paging Teleservice	Yes
Wireless Messaging Teleservice	Yes
Voice Mail Notification	Yes
Wireless Application Teleservice	Yes
Service Category Programming Teleservice	Yes

## Over-The-Air Service Provisioning (OTASP)

### IS-683 features

The MC5728V Mini Card supports [TIA/EIA/IS-683-A](#) for Over-the-Air Service-Provisioning (OTASP) and Parameter Administration (OTAPA) as summarized in Table 12. The MC5728V Mini Card also complies with carrier specific OTASP and OTAPA requirements.

**Table 12: OTASP/OTAPA features**

Feature	Supported?
<a href="#">OTASP</a> (user initiated)	Yes <sup>9</sup>
<a href="#">OTAPA</a> (network initiated)	Yes
<a href="#">NAM</a> Parameter Download	Yes
Preferred Roaming List (PRL) Download	Yes
A-Key Exchange	Yes
<a href="#">OTAPA</a> <a href="#">NAM</a> Lock	Yes
Re-Authenticate Messaging	Yes
Protocol Capability Messaging	Yes

### Internet Over The Air (IOTA) features

The [firmware](#) of the MC5728V Mini Card includes an embedded [IOTA](#) client that includes the following support:

- Automatically initiates and attempts to complete an IOTA session in the MC5728V Mini Card when the network initiates an IOTA session.
- Provides an interface to the host to request the MC5728V Mini Card to initiate and attempt a client initiated IOTA session.
- Provides notifications to the host of status and results of the current IOTA session in the MC5728V Mini Card.
- Provides an interface to the host to cancel, at any time, an active IOTA session running in the MC5728V Mini Card.

<sup>9</sup>Host support is required for this feature.

IOTA feature support is defined in Table 13.

**Table 13: IOTA features**

Feature	Supported?
Bootstrap Provisioning	Yes <sup>10</sup>
Network Initiated Provisioning using WAP Push	Yes
Reassembly of Multiple IOTA Trigger Messages	Yes
HTTP and SSL Support (Download Agent)	Yes
MMC XML and MIME Parser / Assembler	Yes
IS-683-A/B Tunneling	Yes
WBXML Parser / Assembler	Yes
Bearer Selection Table Provisioning	Yes
User NAI Profiles and CDMA Objects	Yes

## Position location

The MC5728V Mini Card supports position location features as specified in Table 14.

**Table 14: Position location features**

Feature	Supported?
TIA/EIA/IS-801.1 Compliant	Yes
FCC E911 Phase II Position Determination Compliance	Yes
TIA/EIA/IS-J-STD-036 Enhanced Wireless 9-1-1 Phase II	Yes
TIA/EIA/IS-801.1 Compliant Data Burst Messaging Transport	Yes
TIA/EIA/IS-801.1 Messaging Compliant TCP/IP Transport	Yes
Mobile initiated, PDE calculated position	Yes
PDE initiated, PDE calculated position (Mobile terminated request)	Yes
Mobile calculated position	Yes
Advanced Forward Link Trilateration (AFLT)	Yes
Compliant with Snap Track Sensor Interface Application and Position Determination Entity (SIA/PDE)	Yes

<sup>10</sup>Host support is required for this feature.

## Additional standards

The following additional standards, required for CDMA operation, are also supported:

- [TIA/EIA-126-D](#), Mobile Station Loop back Service Options Standard—Specifies loop back service options used during testing and certification.
- [TIA/EIA TSB 50](#), User Interface for Authentication Key Entry—Specifies the method for A-Key Entry from the device user interface. Note: Requires host support for compliance.
- [TIA/EIA TSB 58-C](#), Parameter Value Assignments for TIA/EIA Wideband Spread Spectrum Standards—Assigns values to reserved parameters and specifies which are standard and which may be used for proprietary (manufacturer specific) values.
- [CDG 36](#), Markov Service Options for Wideband Spread Spectrum Systems Communications Systems—Specifies the function of specific service options used for one-way, over-the-air testing of mobiles.
- [TIA/EIA/IS-870](#), Test Data Service Option (TDSO) for cdma2000<sup>®</sup> Spread Spectrum Systems—Defines a test data service option for testing of cdma2000<sup>®</sup> mobile units.

## CDMA certification requirements

The MC5728V Mini Card is designed to be fully compliant with the requirements below. However, final product certification requires a fully integrated host device (that incorporates the MC5728V Mini Card).

Tests that require features not supported by the MC5728V Mini Card (as defined in this document) are not supported.

## CDMA parametric performance

The MC5728V Mini Card meets or exceeds [TIA/EIA/IS-98D/E](#) specifications for performance for CDMA2000<sup>®</sup>. The MC5728V Mini Card also meets or exceeds [IS-866](#) for [1xEV-DO](#) specifications for performance.

## Interoperability

The MC5728V Mini Card complies with the following interoperability standards:

- [CDG 22](#)—Stage 2 Interoperability Tests (TIA/EIA/IS-95A)
- [CDG 53](#)—Stage 2 Interoperability Tests (TIA/EIA-95-B)
- [C.S0031-0](#)—Signaling Conformance Tests for CDMA2000® Spread Spectrum Systems (Stage 2 for [TIA/EIA/IS-2000](#))
- [CDG 64](#)—Stage 3 Testing for CDMA2000®
- [C.S0032](#)—Recommended Minimum Performance Standards for cdma2000® High Rate Packet Data Access Terminal ([TIA/EIA/IS-866](#))

## FCC and Industry Canada type acceptance

The MC5728V Mini Card complies with the agency certifications specified in Table 15.

**Table 15: US and Industry Canada compliance requirements**

Compliance area	US regulation	Industry Canada regulation
Emissions	<a href="#">FCC Part 15</a>	<a href="#">ICES-003</a>
Licensed transmission	<a href="#">FCC Part 22, 24</a>	<a href="#">RSS-132, RSS-133</a>

Final product certification depends on the [OEM](#) host device and particularly the OEM antenna implementation. Regulatory agency compliance testing is required for final product certification.

# Electrical Specifications

[Figure 1](#) (page 31) shows how the MC5728V Mini Card is integrated into a host system. The MC5728V Mini Card has these interfaces to the host:

- **Power**—The MC5728V Mini Card relies on the host as its sole power source.
- **Wireless Disable**—The MC5728V Mini Card supports the wireless disable feature as described in the [PCI Express Mini Card Specification](#).
- **Voice**—The MC5728V Mini Card has one differential line-level audio input, and one differential audio output.
- **LED output**—The MC5728V Mini Card by default supports the [LED](#) drive feature as described in the [PCI Express Mini Card Specification](#). If desired, LED behavior can be configured through [NV](#).
- **Antenna**—The MC5728V Mini Card has two U.FL [RF](#) connectors for the main [Rx/Tx](#) path and the Rx diversity path. For more details, see “[RF specifications](#)” (page 43).

Figure 1: MC5728V system block diagram

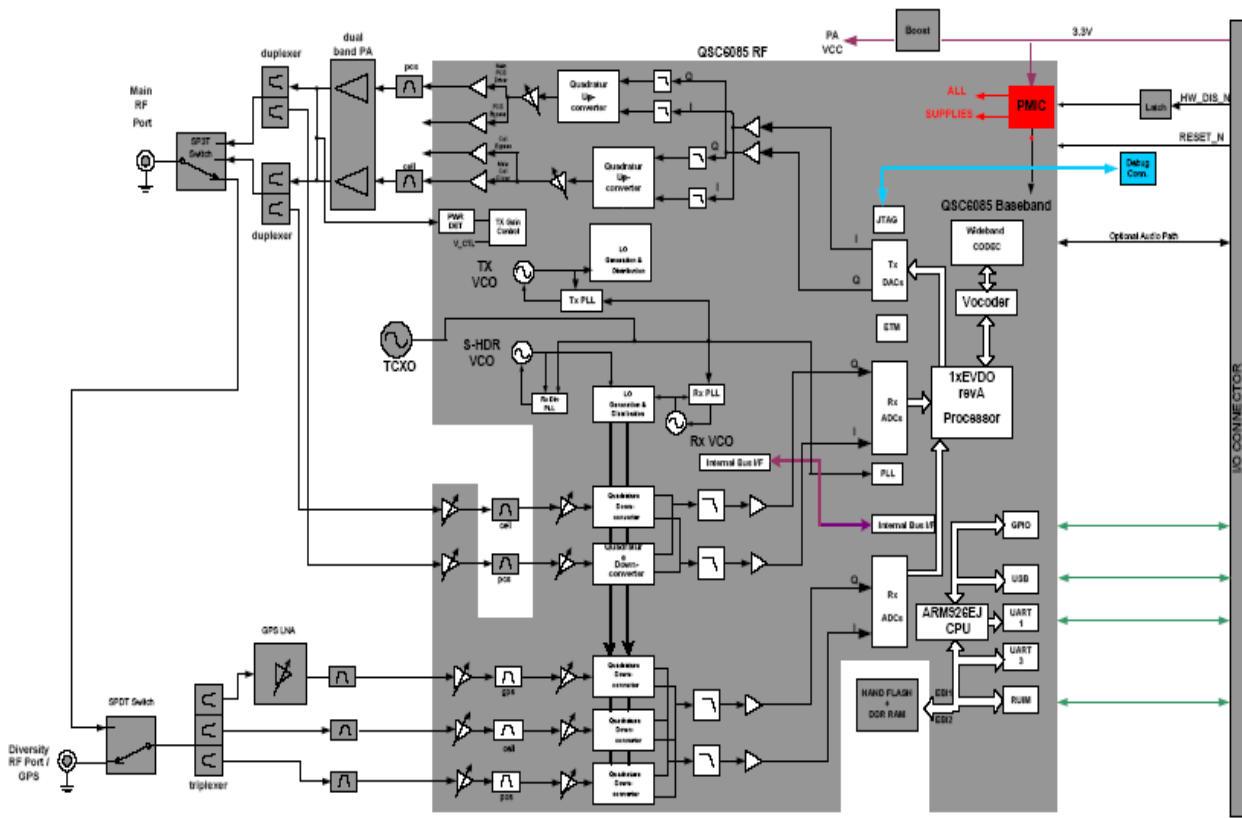

## Host interface

The MC5728V Mini Card has two main interface areas: the host connector, and the RF port(s). The details of these interfaces are described in the sections that follow.

## Pin assignments

The MC5728V Mini Card’s host connector provides the power, LED and USB communications through a single connector.

Detailed pin assignments are shown in the table below.

Table 16: Connector pin assignments

Pin	Signal name	Description	Direction to module	Active state
1	MIC_P	Microphone positive	Input	
2	+3.3V	3.3 V supply	Input	Power
3	MIC_N	Microphone negative	Input	
4	GND	Ground	Input	Power

Pin	Signal name	Description	Direction to module	Active state
5	SPK_P	Speaker positive	Output	
6	DIO_1	Digital IO channel 1	Input	
7	SPK_N	Speaker negative	Output	
8	NC	No Connect		
9	GND	Ground	Input	Power
10	NC	No Connect		
11	VCC_MSM26_DIG	VCC reference for all GPIO digital signals	Output	Power
12	NC	No Connect		
13	NC	No Connect		
14	NC	No Connect		
15	GND	Ground	Input	Power
16	DIO_2	Digital IO channel 2	Input	
17	NC	No Connect		
18	GND	Ground	Input	Power
19	NC	No Connect		
20	W_DISABLE#	Wireless Disable	Input	Low
21	GND	Ground	Input	Power
22	AUXV1	Auxiliary Voltage1 – ADC input	Input	Analog
23	NC	No Connect		
24	+3.3V	3.3V supply	Input	Power
25	NC	No Connect		
26 27	GND	Ground	Input	Power
28	DIO_3	Digital IO channel 3	Input	
29	GND	Ground	Input	Power
30	DIO_4	Digital IO channel 4	Output	
31	NC	No Connect		
32	RI	Ring Indicator. Supports the <a href="#">Wakeup Enable</a> function (page 13)	Output	Low
33	MDL_RESET_N	Module Reset Input	Input	Low
34 35	GND	Ground	Input	Power
36	USB_D-	USB data negative	Input/Output	Differential
37	GND	Ground	Input	Power
38	USB_D+	USB data positive	Input/Output	Differential



Pin	Signal name	Description	Direction to module	Active state
39	+3.3V	3.3 V supply	Input	Power
40	GND	Ground	Input	Power
41	+3.3V	3.3 V supply	Input	Power
42	LED_WWAN#	LED Driver	Output	Low
43	GND	Ground	Input	Power
44	MIO 44/DCD	UART DCD	Output/Input Direction depends on the NV setting. If the setting is Headset Detect, then is Input.	
45	CTS1_N/ PCM_CLK	UART Clear to send / PCM clock	Output	High/Low
46	DSR	UART DSR	Output	
47	RTS1_N/ PCM_DIN	UART Request to send / PCM Data input	Input	High/Low
48	DTR	UART DTR	Input	
49	RXD1/ PCM_DOUT	UART Receive data / PCM Data out	Output	High/Low
50	GND	Ground	Input	Power
51	TXD1/ PCM_SYNC	UART Transmit data/ PCM Synchronize	Input	High/Low
52	+3.3V	3.3 V supply	Input	Power

## Host interface descriptions

This section and the sections that follow provide additional detail on each portion of the host connector interface.

Each pin has a type code as part of its description. The type code is one of the following:

- **A**—Analog Pin
- **I**—Input
- **NP**—No pull
- **O**—Output
- **PU**—Digital Pin, Internal Pull Up
- **PD**—Digital Pin, Internal Pull Down
- **V**—Power or Ground Pin

## Power supply

Power is provided to the MC5728V Mini Card through multiple power and ground pins as described in Table 17.

**Table 17: Power and ground specifications**

Name	Pins	Type	Specification	Parameter	Min	Typ.	Max	Units
+3.3V	2, 24, 39, 41, 52	V	Voltage Range	VCC	3.0	3.3	3.6	V
			Ripple Voltage		-	-	100	mVpp
GND	4, 9, 15, 18, 21, 26, 27, 29, 34, 35, 37, 40, 43, 50	V			-	0	-	V

## USB interface

The [USB](#) interface uses the 3.3 volt regulated voltage from the host device to provide power to the USB transceiver on the MC5728V Mini Card. The USB interface is compliant to [Version 2.0 of the USB standard](#) for full speed operation.

**Table 18: USB interface**

Name	Pin	Description	Type
USB_D-	36	USB Data	A
USB_D+	38	USB Data	A

## Control interface

The MC5728V Mini Card provides signaling for:

- Power control of the MC5728V Mini Card from the host
- Wakeup of the host upon certain events
- [LED](#) driver output.

These signals are summarized in Table 19 and paragraphs that follow. For more detailed information concerning usage and timing of the control signals, see the *Hardware Integration Guide*.

**Table 19: MC5728V Mini Card control signals**

Name	Pin	Description	Type
W_DISABLE#	20	Wireless Disable	PU
RI	32	Ring Indicator. Supports <a href="#">Wakeup Enable</a> (page 13).	PU (configured as output)
LED_WWAN#	42	LED driver	O

The host device uses W\_DISABLE# to disable the module from transmitting (for applications such as airplane mode). Letting this signal float high allows the module to operate normally. This switch follows the behavior as described in the [PCI Express Mini Card Specification](#). This pin has a pull-up resistor to +3.3V.

The modem can use RI to wake the host device upon ring, restoration of radio coverage, and/or receipt of SMS (“WakeUp Enable”).

LED\_WWAN# by default is driven by the module as described in Table 3-5 in the [PCI Express Mini Card Specification](#). If desired, LED behavior can be configured through NV.

Electrical specifications for the Control Interface signals are shown in [Table 20](#) on page 35.

**Table 20: Control signal DC electrical specifications**

Specification	Parameter	Conditions	Min	Typ	Max	Units
Supply voltage	VCC	Regulated by host	3.0	3.3	3.6	V
Low level input voltage	V <sub>IL</sub>		-0.5	0	0.8	V
High level input voltage	V <sub>IH</sub>		2.0	3.3	VCC+0.5	V
Low level output voltage	V <sub>OL</sub>	4.0mA		0	0.2	V
Max high output voltage	V <sub>HMAX</sub>				VCC+0.5	V

## Digital interface

The MC5728V Mini Card provides digital I/O signals that are summarized in Table 21. For more information concerning usage of the control signals, see the *Hardware Integration Guide*.

**Table 21: MC5728V Mini Card digital signals**

Name	Pin	Description	Type
DIO_1	6	Digital IO channel 1	PD
DIO_2	16	Digital IO channel 2	PU
DIO_3	28	Digital IO channel 3	PU
DIO_4	30	Digital IO channel 4	PU
DCD	44	UART DCD	PU
CTS1_N / PCM_CLK	45	UART Clear to send / PCM clock	PU / PD

Name	Pin	Description	Type
DSR	46	UART DSR	NP
RTS1_N / PCM_DIN	47	UART Request to send / PCM Data input	PU / PD
DTR	48	UART DTR	PU
RXD1 / PCM_DOUT	49	UART Receive data / PCM Data out	PU / PD
TXD1 / PCM_SYNC	51	UART Transmit data / PCM Synchronize	PD / PD

Pins 45~51 (odd) can be selected for either UART or PCM audio interface.

Electrical specifications for the Digital Interface signals are shown in Table 22.

**Table 22: Digital signal DC electrical specifications**

Specification	Parameter	Conditions	Min	Typ	Max	Units
Supply voltage (VCC_MSM26_DIG)	VCC	Regulated by modem	2.5	2.6	2.7	V
Low level input voltage	V <sub>IL</sub>		-0.3	0	0.35*VCC	V
High level input voltage	V <sub>IH</sub>		0.65*VCC	2.6	VCC+0.3	V
Low level output voltage	V <sub>OL</sub>	1.0mA		0	0.45	V
High level output voltage	V <sub>HMAX</sub>	1.0mA	VCC-0.45V	VCC		V

## Analog interface

The MC5728V Mini Card provides analog signals for audio, plus an auxiliary analog-to-digital input. These signals are summarized in Table 23. For more information about usage of the analog signals, see the *Hardware Integration Guide*.

**Table 23: MC5728V Mini Card analog signals**

Name	Pin	Description	Type	Notes
MIC1_P	1	Microphone input, positive	AI	Differential audio input, line level
MIC1_N	3	Microphone input, negative	AI	Differential audio input, line level
SPK1_P	5	Speaker output, positive	AO	Differential audio output, line level
SPK1_N	7	Speaker output, negative	AO	Differential audio output, line level
AUXV1	22	Auxiliary Voltage input	AI	Input range: 0~2.6V

**Note:** The microphone input is a line-level input only. If used directly with a microphone transducer, the microphone input requires a pre-amplifier.

**Table 24: Recommended operating conditions**

Parameter	Min	Nom	Max	Units
Supply voltage, $AV_{DD}$ , $HPH_{V_{DD}}$ , $EAR_{V_{DD}}$	2.0	2.1	2.2	V
Supply voltage $V_{neg}$		-1.8		V
Load impedance between $EAR1OP$ and $EAR1ON$	25.6	32		$\Omega$
Load impedance between $HPH_L$ and $HPH_{VREF}/AV_{SS}$ , $HPH_R$ and $HPH_{VREF}/AV_{SS}$	12	16		$\Omega$
Load impedance between $LINE_{ON}$ and $LINE_{OP}$ (differential mode)		600		$\Omega$
Load impedance between $LINE_{OUT}_L$ and $AV_{SS}$ , $LINE_{OUT}_R$ and $AV_{SS}$		600		$\Omega$
Operating temperature range	-40		+100	$^{\circ}C$

Note: Voltages at analog inputs, outputs, and  $V_{DD}$  are with respect to  $AV_{SS}$ .

**Table 25: Audio transmit path performance characteristics for MIC1\_P/MIC1\_N**

Parameter	Test conditions	Min	Typ	Max	Units
Full-scale input voltage, 0 dB gain (Overload voltage)	Voltage across either MIC1P and MIC1N, MIC2P and MIC2N, or LINEIN_LP and LINEIN_LN	0.89	1.00 (results in -3.5 dBFS PCM output)	1.12	Vrms
Full-scale input voltage, 24 dB gain (Overload voltage)	Voltage across either MIC1P and MIC1N, MIC2P and MIC2N, or LINEIN_LP and LINEIN_	56.2	61.3 (results in -3.5 dBFS PCM output)	70.8	mVrms
Gain error (absolute)	0 and 24 dB gain settings for all inputs. Measured at 13 dB below the maximum input level for the given gain setting.	-1.0		1.0	dB
Output referred noise	0 dB analog gain, input grounded A-weighted			-85.5	dBFS
	24 dB analog gain, input grounded A-weighted			-80.5	dBFS
Tx path dynamic range, 0 dB gain	f=1.02 kHz, output = -60 dB FS, A-weighted	82			dB
Tx path dynamic range, 24 dB gain	f=1.02 kHz, output = -60 dB FS, A-weighted	77			dB
Input impedance	Differential input impedance Input = -3 dBV @ 1 KHz Through series 10 K and 450 µF Gain = 0dB	16	20	24	k
Input impedance	Single-ended input impedance Input = -3 dBV @ 1 KHz Through series 10 K and 450 µF Gain = 0 dB	8	10	12	k
THD+N ratio, 0 dB gain, high output level	0 dB analog gain, 0 dB codec Tx gain, f= 1.02 kHz, output = -1 dB FS <b>Note:</b> Measurement BW = 22 to Fs/2; (no A-weighting)			0.1	%
THD+N ratio, 24 dB gain, high output level	24 dB analog gain, 0 dB codec Tx Gain, f= 1.02 kHz, output = -1 dB FS <b>Note:</b> Measurement BW = 22 to Fs/2; (no A-weighting)			0.15	%
Tx path off channel isolation	Off channel signal level = 1 Vrms; on channel = 0 V.	70			dB
Frequency response, passband	DC to 0.375 * Fs, Fs= 8k and 16k	-0.5		0.5	dB

Parameter	Test conditions	Min	Typ	Max	Units
Frequency response, stopband	$f = 0.4975 * F_s$ , $F_s = 8k$ and $16k$			-14	dB
Common mode DC voltage	Vdd = 2.0 Vdc minimum		1.00		V(DC)

**Note:** The total transmit channel gain in the Low gain configuration is +6 dB.

**Table 26: Audio receive path performance characteristics for SPK1\_P/SPK1\_N**

Parameter	Test conditions	Min	Typ	Max	Units
DAC to EAROP/EARON full-scale output	$f=1.02$ kHz, 0 dB FS input, measure resulting analog output level. <b>Note:</b> +/- 1 dB level error.	1.127	1.265	1.419	Vrms
Gain error (absolute)	$F = 1.02$ kHz, -13 dBFS	-1		+1	dB
EAROP/EARON output power, 4% or less THD+N	$f=1.02$ kHz, 0 dB FS		50.0		mW
DAC to EAROP/EARON gain error relative to gain @ -13 dB FS input level	$f=1.02$ kHz, -60 dB FS	-1.2		1.2	dB
DAC to EAROP/EARON output noise level	Input = -999 dBFS; $F_s = 8$ k or 16 k, A-weighted			70	$\mu$ Vrms
DAC to EAROP/EARON signal-to-noise ratio	Ratio of full-scale output to output noise level	84.1			dB
DAC to EAROP/EARON dynamic range	$f = 1.02$ kHz, input = -60 dB FS; $F_s = 8$ k or 16 k; A-weighted	82.1			dB
DAC to EAROP/EARON power supply rejection	$0 < f < 20$ kHz, 200 mVpp ripple at Vdd input pin	65			dB
DAC + EAROP/EARON supply current, $F_s = 8k$ or $16k$	Rx DAC left-enabled, Rx DAC right disabled, EAROP/EARON enabled, input = 0			8	mA
Frequency response, passband	20Hz to $0.375 * F_s$ , $F_s = 8$ k and 16 k, -6 dBFS input	-0.5		0.5	dB
Frequency response, stopband	$f \geq 0.4975 * F_s$ , $F_s = 8$ k and 16 k, -6 dBFS input			-14	dB
Common mode DC voltage	Vdd 2.1 vdc		1		V(DC)

## PCM interface

The MC5728V Mini Card's PCM audio interface features the following characteristics:

- Runs in master mode
- Supports Linear, A-Law, and m-Law companding algorithms
- Supports 128 kHz long frame sync and 2.048 MHz short frame sync operation

The PCM audio interface, described in the figures and tables that follow, is selected at run-time using AT commands—both the PCM audio and UART interfaces share the same physical pins. Once selected, the chosen interface becomes effective after the module resets.

Note: The selected interface persists until it is explicitly changed using AT commands.

**Table 27: PCM digital audio interface connections**

Name	Pin	Description	Type
PCM_CLK	45	PCM clock	PD
PCM_DIN	47	PCM data in	PD
PCM_DOUT	49	PCM data out	PD
PCM_SYNC	51	PCM sync	PD

**PCM interface (2.048 MHz) timing diagrams and parameters**

**Figure 2: Timing diagram: PCM\_SYNC**

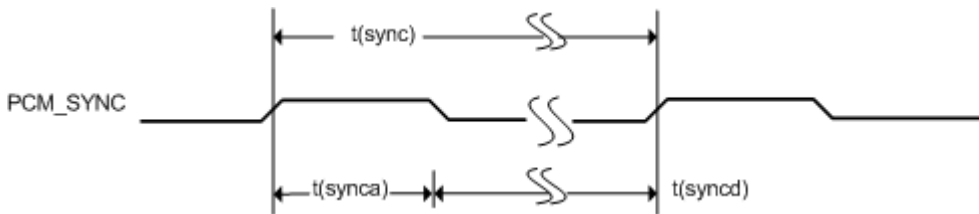

**Figure 3: Timing diagram: PCM\_CODEC to QSC6085**

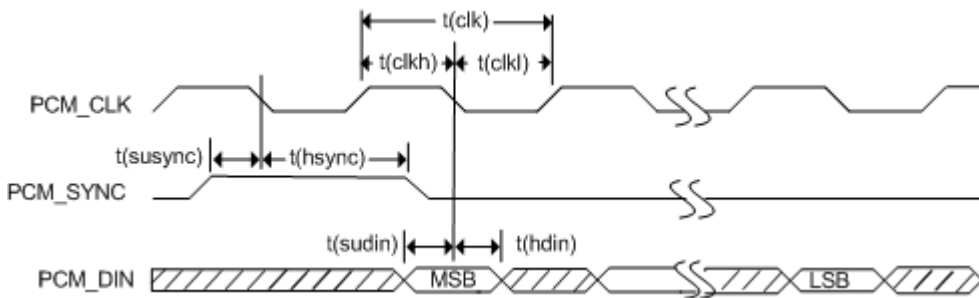



Figure 4: Timing diagram: QSC6085 to PCM\_CODEC

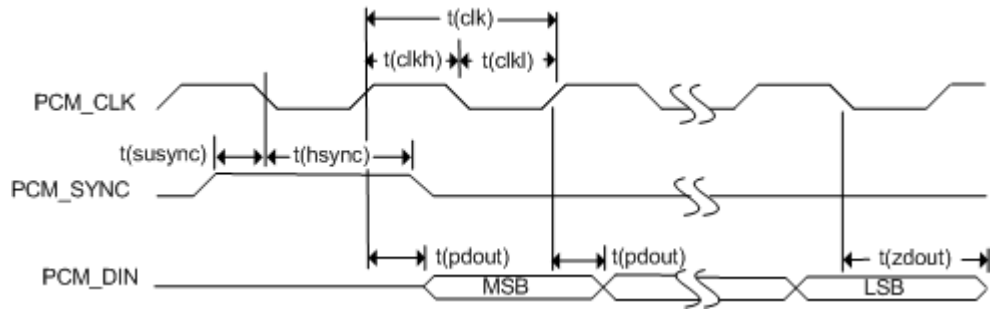

Table 28: PCM\_CODEC timing parameters

Parameter	Description	Min	Typ.	Max	Units	Notes
t(sync)	PCM_SYNC cycle time (PCM_SYNC_DIR=1)		125		$\mu\text{s}$	1
	PCM_SYNC cycle time (PCM_SYNC_DIR=0)		125		$\mu\text{s}$	
t(synca)	PCM_SYNC asserted time (PCM_SYNC_DIR=1)	400	500		ns	1
	PCM_SYNC asserted time (PCM_SYNC_DIR=0)				ns	
t(syncd)	PCM_SYNC de-asserted time (PCM_SYNC_DIR=1)		124.5		$\mu\text{s}$	1
	PCM_SYNC de-asserted time (PCM_SYNC_DIR=0)				$\mu\text{s}$	
t(clk)	PCM_CLK cycle time (PCM_CLK_DIR=1)	400	500		ns	1
	PCM_CLK cycle time (PCM_CLK_DIR=0)				ns	
t(clkh)	PCM_CLK high time (PCM_CLK_DIR=1)	200	250		ns	1, 2
	PCM_CLK high time (PCM_CLK_DIR=0)				ns	
t(clkl)	PCM_CLK low time (PCM_CLK_DIR=1)	200	250		ns	1, 2
	PCM_CLK low time (PCM_CLK_DIR=0)				ns	
t(susync)	PCM_SYNC setup time to PCM_CLK falling		150		ns	
	(PCM_SYNC_DIR = 1, PCM_CLK_DIR = 1)					
	PCM_SYNC setup time to PCM_CLK falling				ns	
	(PCM_SYNC_DIR = 0, PCM_CLK_DIR = 0)					
t(hsync)	PCM_SYNC hold time after PCM_CLK falling		300		ns	
	(PCM_SYNC_DIR = 1, PCM_CLK_DIR = 1)					
	PCM_SYNC hold time after PCM_CLK falling				ns	
	(PCM_SYNC_DIR = 0, PCM_CLK_DIR = 0)					
t(sudin)	PCM_DIN setup time to PCM_CLK falling	50			ns	
t(hdin)	PCM_DIN hold time after PCM_CLK falling	10			ns	
t(pdout)	Delay from PCM_CLK rising to PCM_DOUT valid			350	ns	
t(zdout)	Delay from PCM_CLK falling to PCM_DOUT HIGH-Z		160		ns	

Notes:

1. This value assumes that CODEC\_CTL is not being used to override the CDMA CODEC clock and sync operation.
2.  $t(\text{clkh})$  and  $t(\text{clkl})$  are independent of PCM\_CLK\_SENSE.

**Auxiliary PCM (128 kHz) interface timing diagrams and parameters**

**Figure 5: Timing diagram: AUX\_PCM\_SYNC**

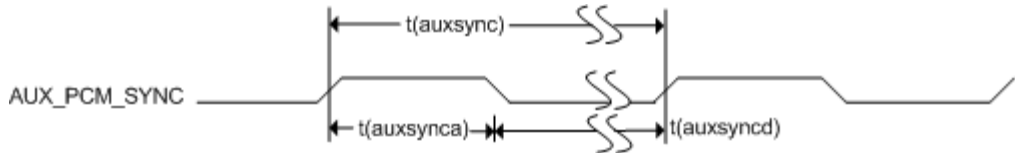

**Figure 6: Timing diagram: AUX\_PCM\_CODEC to QSC6085**

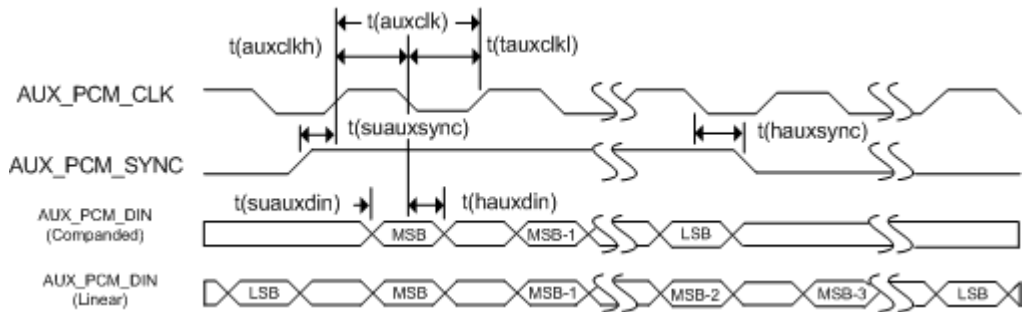

**Figure 7: Timing diagram: QSC6085 to AUX\_PCM\_CODEC**

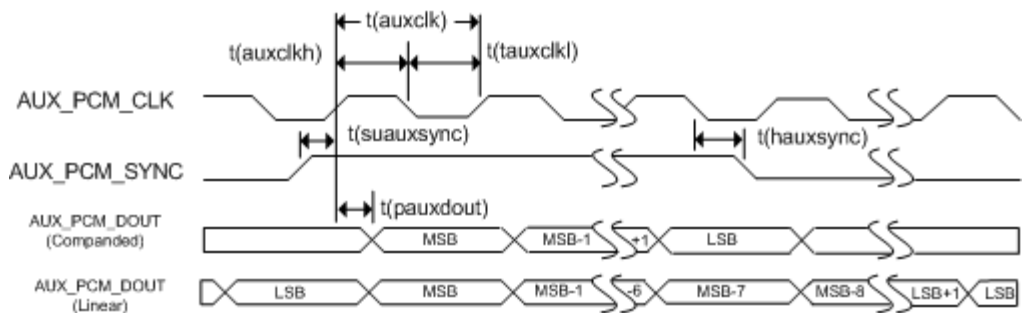

**Table 29: AUX\_CODEC timing parameters**

Parameter	Description	Min	Typ.	Max	Units	Notes
t(auxsync)	AUX_PCM_SYNC cycle time		125		μs	1
t(auxsynca)	AUX_PCM_SYNC asserted time	62.4	62.5		μs	1
t(auxsyncd)	AUX_PCM_SYNC de-asserted time	62.4	62.5		μs	1
t(auxclk)	AUX_PCM_CLK cycle time		7.8		μs	1
t(auxclkh)	AUX_PCM_CLK high time	3.8	3.9		μs	1
t(auxclkl)	AUX_PCM_CLK low time	3.8	3.9		μs	1
t(suauxsync)	AUX_PCM_SYNC setup time to AUX_PCM_CLK rising	1.95			μs	
t(hauxsync)	AUX_PCM_SYNC hold time after AUX_PCM_CLK rising	1.95			μs	
t(suauxdin)	AUX_PCM_DIN setup time to AUX_PCM_CLK falling	70			ns	
t(hauxdin)	AUX_PCM_DIN hold time after AUX_PCM_CLK falling	20			ns	
t(pauxdin)	Propagation delay from AUX_PCM_CLK AUX_PCM_DOUT valid			50	ns	

Notes:

1. This value assumes that CODEC\_CTL is not being used to override the CDMA CODEC clock and sync operation.

## RF specifications

The MC5728V Mini Card does not have an integrated antenna. The RF connection is supported through two RF connectors.

The main RF connector is made by Hirose (Hirose U.FL # CL331-0471-0-10) and is a 3 mm x 3 mm low profile connector that supports a coaxial cable connection to the module. The path is assumed to be 50 ohms. This connector is installed on the top side (see [Figure 8](#) on page 44).

For receive diversity, an additional Hirose U.FL connector is installed on the top side. This is to support a coaxial cable connection to the second antenna.

**Figure 8: Location of connectors**

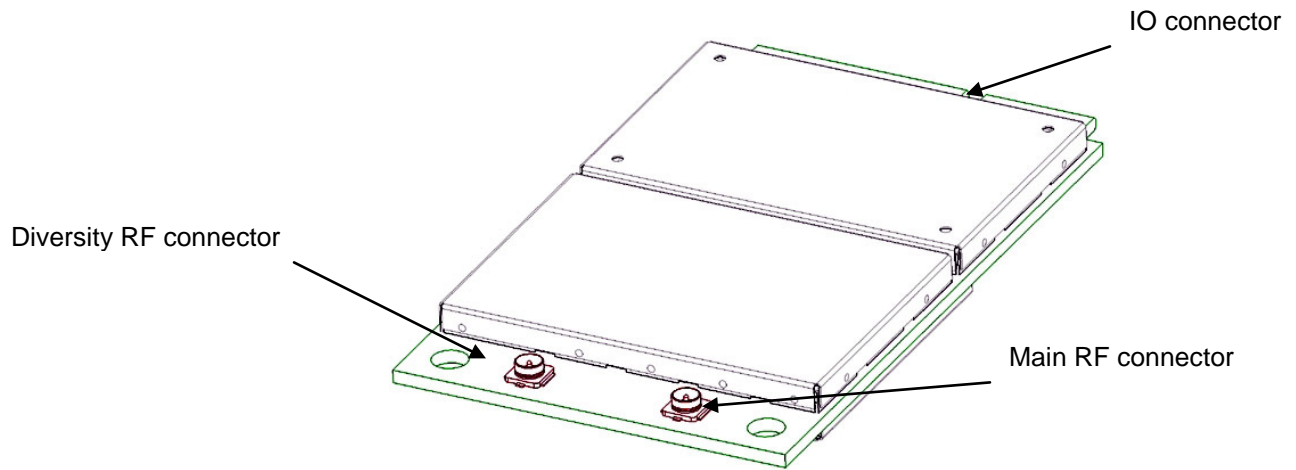

**Table 30: Supported bands**

	Main antenna	Auxiliary (diversity) antenna
US Cell	✓	✓
US PCS	✓	✓
GPS		✓

**Table 31: Main antenna specifications**

Parameter	Min	Typ	Max	Units	Notes
Cable loss	-	-	0.5	dB	Maximum loss to antenna
Impedance	-	50	-	$\Omega$	Antenna load impedance
VSWR	-	-	2.5:1		Maximum allowed VSWR of antenna

**Table 32: RF performance**

Parameter	Min	Typ	Max	Units	Notes
Maximum output power	+23.0	+24.0	+25.0	dBm	+25.0 dBm is the maximum output power for IS-95, IS-2000, 1xEV-DO Revision 0, and 1xEV-DO Revision A.
RX sensitivity (US Cell)	-	-108	-	dBm	IS-2000 SO2
RX sensitivity (US PCS)	-	-107	-	dBm	IS-2000 SO2
RX sensitivity (US Cell)	-	-111	-	dBm	1xEV-DO Revision 0, DRC4
RX sensitivity (US PCS)	-	-109	-	dBm	1xEV-DO Revision 0, DRC4

**Table 33: Diversity antenna specifications**

Parameter	Min	Typ	Max	Units	Notes
Cable loss	-	-	0.5	dB	Maximum loss to antenna
Impedance	-	50	-	$\Omega$	Antenna load impedance
VSWR	-	-	2.5:1		Maximum allowed VSWR of antenna
Isolation between main and diversity antenna	10	-	-	dB	Minimum isolation

If the antenna connection is shorted or open, the radio module will not sustain permanent damage. For additional information, see the *Hardware Integration Guide* (document 2130114).

**Table 34: GPS sensitivity**

Parameter	Typical	Units	Notes
Single-satellite sensitivity w/SA	-159	dBm	Sensitivity is where 50% of the visible satellites can be acquired

## GPS specifications

**Table 35: GPS specifications**

Satellite channels	12 channel, continuous tracking
Protocols	NMEA 0183 V3.0
Acquisition time	Re-acquisition: 2 sec. Hot start: 9 sec. Warm start: 35 sec. Cold start: 39 sec.
Accuracy	Horizontal: < 3 m (50%); < 8 m (90%) Altitude: < 10 m (50%); < 16 m (90%) Velocity: 0.06 m/sec.
Sensitivity	Tracking: -152 dBm Acquisition: -142 dBm
Operational limits	Altitude < 18,000 m or velocity: 515 m/sec (either limit may be exceeded, but not both)

## GPS antenna specifications

**Table 36: GPS antenna specifications**

Gain	Maximum gain and uniform coverage in high-angle elevation and zenith. Gain in the azimuth plane is <b>not</b> desired.
Average 3D gain	> -5 dBi
VSWR	Typical value < 2:1
Isolation (GPS ↔ Main)	> 10 dB in all related bands
Polarization	Any, other than LHCP (left-hand circular polarized)

## Power consumption

Table 37 summarizes the MC5728V Mini Card's DC power consumption in various modes. **This table is preliminary and subject to change.**

**Table 37: DC power consumption (+3.3V)**

Description	Band	Typ	Max	Units	Notes
IS-95 Standby current	PCS or Cellular	4.7	-	mA	SCI=2, PCH = full rate, Registration rate = 30 min, Sector power -70 dBm. Neighbor list on.
IS-2000 Standby current	PCS or Cellular	2.1	-	mA	SCI=2, PCH = full rate, Registration rate = 30 min, Sector power -70 dBm. Neighbor list on. QPCH on.
Hybrid Mode Standby current	PCS or Cellular	3.5	-	mA	SCI=2, PCH = full rate, Registration rate = 30 min, Sector power -70 dBm. Neighbor list on. QPCH on. Modem idling on both IS-2000 and 1xEV-DO networks.
IS-2000 Talk current, Reverse Pilot Channel Gating Disabled	PCS	203	-	mA	SO9, RC5 (Fwd) / RC4 (Rvs), CDG Urban Profile
		211	-	mA	SO9, RC5 (Fwd) / RC4 (Rvs), CDG Suburban Profile
	Cellular	185	-	mA	SO9, RC5 (Fwd) / RC4 (Rvs), CDG Urban Profile
		201	-	mA	SO9, RC5 (Fwd) / RC4 (Rvs), CDG Suburban Profile
IS-2000 Talk current, Reverse Pilot Channel Gating enabled	PCS	226	-	mA	SO9, RC5 (Fwd) / RC4 (Rvs), CDG Urban Profile
		248	-	mA	SO9, RC5 (Fwd) / RC4 (Rvs), CDG Suburban Profile
	Cellular	204	-	mA	SO9, RC5 (Fwd) / RC4 (Rvs), CDG Urban Profile
		224	-	mA	SO9, RC5 (Fwd) / RC4 (Rvs), CDG Suburban Profile
IS-2000 1X Data current	PCS	326	-	mA	SO32, RC3 (Fwd) / RC3 (Rvs), 153.6 kbps (Fwd) / 76.8 kbps (Rvs), CDG Urban Profile, USB active
		367	-	mA	SO32, RC3 (Fwd) / RC3 (Rvs), 153.6 kbps (Fwd) / 76.8 kbps (Rvs), CDG Suburban Profile, USB active
	Cellular	283	-	mA	SO32, RC3 (Fwd) / RC3 (Rvs), 153.6 kbps (Fwd) / 76.8 kbps (Rvs), CDG Urban Profile, USB active
		321	-	mA	SO32, RC3 (Fwd) / RC3 (Rvs), 153.6 kbps (Fwd) / 76.8 kbps (Rvs), CDG Suburban Profile, USB active

# MC5728V Mini Card Product Specification

Description	Band	Typ	Max	Units	Notes
IS-856 1xEV-DO Revision 0 Data current	PCS	354	-	mA	CDG Urban Profile, USB active
		406	-	mA	CDG Suburban Profile, USB active
	Cellular	308	-	mA	CDG Urban Profile, USB active
		358	-	mA	CDG Suburban Profile, USB active
IS-856A 1xEV-DO Revision A Data current	PCS	370	-	mA	CDG Urban Profile, USB active
		422	-	mA	CDG Suburban Profile, USB active
	Cellular	330	-	mA	CDG Urban Profile, USB active
		379	-	mA	CDG Suburban Profile, USB active
Maximum peak current – operational	PCS or Cellular	-	1.2	A	Max RF output power, full rate, full operating temperature range.
Maximum peak current – call connected (voice or data)		-	1.0	A	Max RF output power, full rate, full operating temperature range
Module OFF leakage current		250	-	µA	20k Pull-up on W_DISABLE#

The MC5728V Mini Card does not have its own power source; for power, it depends on the host device. Typical values are measured at room temperature. Minimum and maximum values are measured over the entire operating temperature range. Input voltage requirements are described in “Power supply” on page 34.



# Software Interface

## Physical interface options

The MC5728V Mini Card supports communication with the host via the [USB](#) interface.

The USB interface can be dynamically configured to operate in one of two modes:

- **Non-MUX mode** — 3 sets of endpoints are provided by the USB interface. The primary set of endpoints is for the data channel; the second set is for either the control or diagnostics channel (configured through [NV](#)), and the third set is currently reserved for future use. Non-MUX mode is the default mode of the USB interface whenever the MC5728V Mini Card's [firmware](#) boots up.
- **MUX mode** — After the MC5728V Mini Card's firmware boots up, the USB interface can be dynamically switched to MUX mode. In this mode, only the primary set of endpoints are used, and all of the channels supported by the MC5728V Mini Card are multiplexed over this single set of endpoints by using the GSM 3GPP 27.010 multiplexing protocol. In this mode, the data, control, and diagnostic channels are all accessible over the USB interface simultaneously.

The MC5728V Mini Card supports three logical interfaces:

- **Data channel** — Supports [AT](#) command and [PPP](#) packet exchange during data calls
- **Control channel** — Supports modem control and status, call processing, and event notification
- **Diagnostic channel** — Supports the QUALCOMM Diagnostic Monitoring protocol used by support tools

## Data channel interface

The data channel supports the [AT](#) command set defined by [TIA/EIA/IS-707.3](#). AT command set support is described in the *AT Command Reference Guide*.

## Control channel interface

The control channel is used to communicate to the modem via [CnS](#) messaging. The general categories of CNS messages are described below. Detailed message formats and descriptions are found in the *CnS Reference*.

**Table 38: CNS message categories**

CNS message category	Description
Hardware Characteristic	Allows discovery of the hardware characteristics (versions, and so on).
Hardware Configuration	Messages used to test and configure the modem hardware.
Device Management	Messages related to OMA-DM (a device management protocol specified by the Open Mobile Alliance).
Account Management	Messages related to activation and account management.
Network Information	Messages related to information about the network and radio signal.
Data Services	Messages related to data connection management and services.
Voice Call Management	Messages related to voice call and connection management.
SMS Messages	Messages related to the control and handling of SMS message.
IOTA Messages	Messages related to Internet Over The Air, supported by some service providers.
Location Based Services Messages	Messages related to the LBS feature supported by some carriers/networks.
Additional Features	Messages that handle additional features supported by the modem.

## Support tools

The diagnostic channel interface of the MC5728V Mini Card is compatible with the following support tools from Sierra Wireless and authorized third-parties:

- Directed Test tool
- Update tool
- Sierra Wireless Product Support Tool (PST)
- CDMA Air Interface Tool (CAIT) from QUALCOMM
- QXDM from QUALCOMM
- Universal Diagnostic Monitor (UDM) from Spirent Communications
- Universal Product Support Tool (UPST) from Spirent Communications

## Other features

### Manufacturing test support

The MC5728V Mini Card supports the following features for manufacturing tests:

- Compatibility with the current manufacturing test software (C-wrapper, loader for flashing)
- Retry mechanisms for software download packets
- A test mode designed to minimize the startup sequence time for the MC5728V Mini Card
- [PRI](#) table read/write as a single object
- Ability to read/write all [NV](#) and PRI values individually

### Memory requirements

[NV](#) memory on the MC5728V Mini Card is available for storage of ring tones, audio files, and so on. The amount of this memory available for storage is to be determined.

# Mechanical and Environmental Specifications

**Note:** After performing the non-operational tests (for example, vibration, shock, and drop), the MC5728V Mini Card meets all operating parameters.

The MC5728V Mini Card complies with the mechanical and environmental specifications in this section. Final product conformance to these specifications depends on the [OEM](#) device implementation.

**Table 39: Mechanical and environmental specifications**

<b>Temperature</b>	Operational	-30°C to +60°C – Full <a href="#">RF</a> compliance +60°C to +75°C – Reduced RF performance (from <a href="#">TIA/EIA/IS-98D/E</a> )
	Non-operational	-40°C to +85°C, 96 hours (from MIL-STD 202 Method 108)
<b>Relative Humidity</b>	Non-operational	85°C, 85% relative humidity for 48 hours (non condensing)
<b>Vibration</b>	Non-operational	Random vibration, 10 to 1000 Hz, nominal 6 G RMS in each of 3 mutually perpendicular axes. The test duration for each axis is 60 minutes, for a total test time of 3 hours.
<b>Shock</b>	Non-operational	Half sine shock, 2 ms, 180 in/sec (375 g). Tested in each of three mutually perpendicular axes, positive and negative (5 x 6, 30 bumps total).
<b>Drop</b>	Non-operational	1 m on concrete on each of 6 faces, 2 times (module only).
<b>Electrostatic discharge</b>	Operational	The RF port (antenna launch and RF connector) complies with the <a href="#">IEC 61000-4-2</a> standard: Electrostatic Discharge Immunity: Test: Level3 Contact Discharge: ±6 kV Air Discharge: ±8 kV
	Non-operational	The host connector Interface complies with the following standards: +/- 125 V Human Body Model ( <a href="#">JESD22-A114-B</a> ) +/- 100 V Charged Device Model ( <a href="#">JESD22-C101</a> )
<b>Thermal consideration</b>		See the <i>Hardware Integration Guide</i> .
<b>Form factor</b>		PCI-Express Mini Card shielded with metal and metalized fabric

# Mechanical and Environmental Specifications

<b>Dimensions</b>	Length:	51 mm
	Width	30 mm
	Thickness	4.5 mm
	Weight	Approximately 12g
See <a href="#">Figure 10</a> on page 54.		

**Figure 9: Top and bottom view**

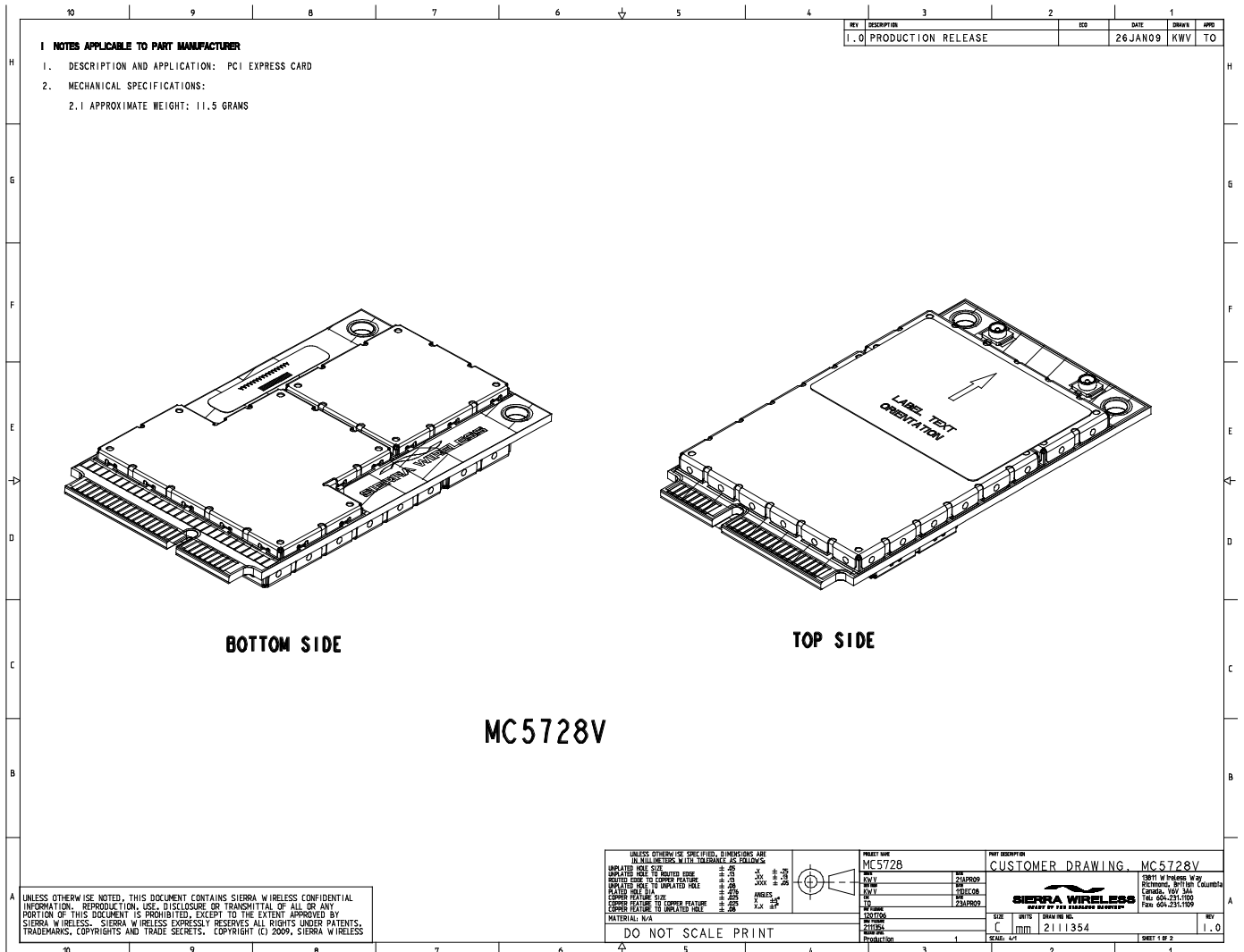
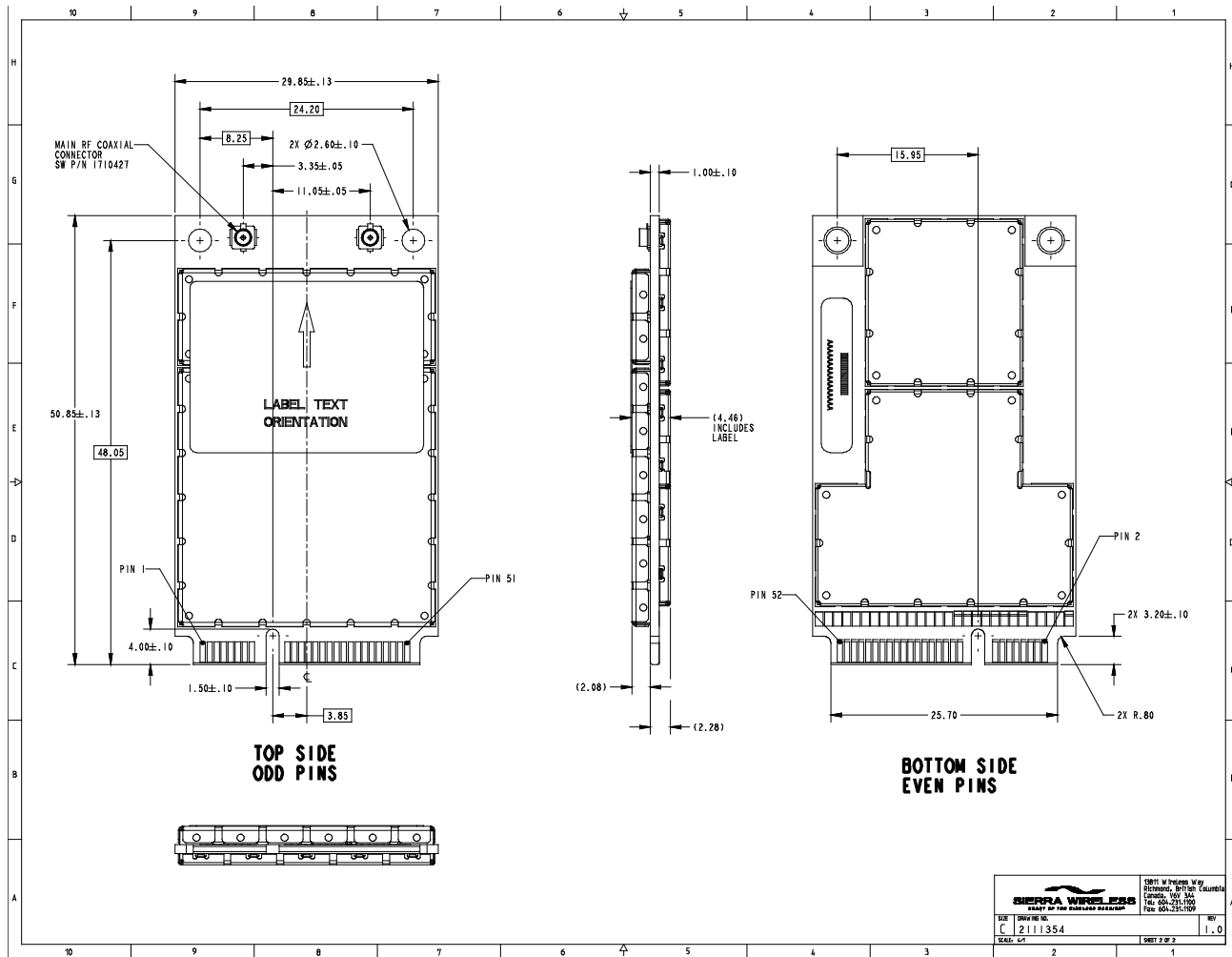
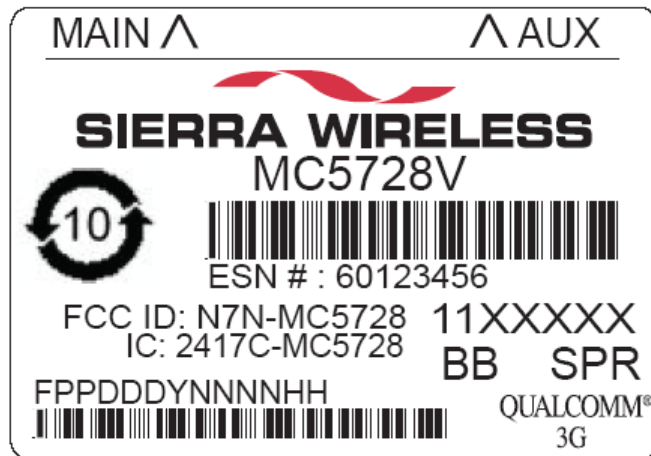

Figure 10: Dimensioned view



## Labeling

Figure 11: MC5728V Mini Card unit label (19.4 x 28.2mm)



The MC5728V Mini Card label is non-removable and contains:

- Sierra Wireless logo and product name (MC5728V)
- [ESN](#) or [MEID](#)
- [SKU](#) number (when required)
- Factory Serial Number ([FSN](#)) in alphanumeric format
- Batch revision number in hexadecimal format
- Manufacturing date code
- Licensed vendor logo

---

**Note:** The MC5728V MiniCard supports [OEM](#) partner specific label requirements.

---

# Additional Requirements

## Regulatory approvals

The MC5728V PCI-Express Mini Card meets appropriate regulatory requirements, including [FCC Parts 2, 15, 22, and 24](#). Formal testing and approval will still be needed based on the Integrator's particular host platform. The Integrator is also responsible for obtaining any other required regulatory approvals in target markets for the finished product.

### FCC

For North American operation, the host product is required to meet appropriate regulatory approvals for stand-alone operation, including [FCC parts 2, 15, 22, and 24](#) approvals.

The MC5728V PCI-Express Mini Card has an FCC ID for mobile applications. This includes approval by a test laboratory for FCC parts [22](#) and [24](#) conductive requirements.

Radiated tests ([SAR](#), [ERP](#), spurious harmonics) are dependent on the antenna configuration and cannot be done independent of the host platform, including implemented antenna design.

FCC Part [15](#) tests must be performed on the end-device and are therefore the Integrator's responsibility.

The Sierra Wireless MC5728V PCI-Express Mini Card has been granted modular approval for mobile applications. Integrators may use the MC5728V PCI-Express Mini Card in their host device that can be categorized as Mobile Devices without additional FCC certification approvals if the following conditions are met (otherwise, additional FCC approvals must be obtained).

- At least 20 cm (7.88") separation distance between the antenna and the user's body must be maintained at all times.
- To comply with FCC regulations limiting both maximum RF output power and human exposure to RF radiation, the maximum antenna gain, including cable loss, must not exceed 4.95 dBi in the cellular band and 3.55 dBi in the [PCS](#) band.



- The MC5728V PCI-Express Mini Card and its antenna must not be collocated or operating in conjunction with any other transmitter or antenna within the host device.
- A label must be affixed to the outside of the host device into which the MC5728V PCI-Express Mini Card is incorporated, with a statement similar to the following: This device contains TX FCC ID: N7N-MC5728.
- A user manual with the host device must clearly indicate the operating requirements and conditions to ensure compliance with current FCC RF exposure guidelines.

The FCC defines a **mobile** device as being designed for use “in other than fixed locations and to generally be used in such a way that a separation distance of at least 20 centimeters is normally maintained between radiating structures and the body of the user or nearby persons.”

The FCC defines a **portable** device as being “designed to be used with any part of its radiating structure in direct contact with the user’s body or within 20 centimeters of the body of the user or bystanders under normal operating conditions.”

### **Assistance provided by Sierra Wireless**

Extended [AT](#) commands have been implemented to assist with performing the FCC tests.

Sierra Wireless offers additional assistance to integrators with the regulatory approvals process, if required.

## CDG

### CDG-1

The MC5728V PCI-Express Mini Card has been tested and approved for [CDG 1](#).

### CDG-2

The MC5728V PCI-Express Mini Card has been tested/verified on Nortel, Lucent, and Motorola carrier infrastructure for CDG 2/IOT. Future testing with other infrastructure providers will be conducted as necessary to achieve Network Operator approvals for host platforms. Sierra Wireless will provide to integrators the CDG 2 modem test reports, which can be provided to Network Operators as part of their CDG 3/approval requirements. Some Network Operators may require regression testing of your finished unit at one or more infrastructure vendor(s).

### CDG-3

The integrator is responsible for testing the finished system. The test process will be determined with the chosen Network Operator(s) and depends on the integrator's business relationship with them as well as the product's application and sales channel strategy. Sierra Wireless offers assistance to integrators with the CDG-3 testing process, if required.

## Integration requirements

When integrating the MC5728V PCI-Express Mini Card, the following items need to be addressed:

- **Mounting**, and its effect on temperature, shock, and vibration performance
- **Power supply**, and the impact on battery drain and possible RF interference
- **Antenna location and type**, and their impact on RF performance
- **Regulatory approvals**, as discussed in "[Regulatory approvals](#)" (page 56)
- **Service provisioning**, manufacturing process
- **Software**, as discussed in "[Software Interface](#)" (page 49)
- **Host interface**, compliance with interface voltage levels

Sierra Wireless provides, in the document suite, guidelines for successful integration of the MC5728V PCI-Express Mini Card, and also offers integration support services as necessary.

# Appendix A: Service Option Support

**Table 40: Service Option support**

Service Option (SO)	Description	Supported?
1	Basic Variable Rate Voice Service	No
2	Mobile Station Loop back (RS1)	Yes
3	Enhanced Variable Rate Voice Service (8 kbps)	Yes
4, 4100	Asynchronous Data Service (RS1)	Yes
5, 4101	Group 3 Facsimile (RS1)	Yes
6	Short Message Services	Yes
7, 4103	Packet Data Service (IP Stack Only)	Yes
9	Mobile Station Loop back (RS2)	Yes
12	Asynchronous Data Service (RS2)	Yes
13	Group 3 Facsimile (RS2)	Yes
14	Short Message Services	Yes
15	Packet Data Service (IP Stack Only)	Yes
17, 32768	High Rate Voice Service (13 k)	Yes
18-19	Over-the-Air Service Administration	Yes
20-21	Group 3 Analog Facsimile	No
22	High Speed Packet Data Services	Yes
23	High Speed Packet Data Services	No
24	High Speed Packet Data Services	No
25	High Speed Packet Data Services	Yes
30-31	Supplemental Code Channel Loop back	No
32	Test Data Service Option (TDSO)	Yes
33	1X High Speed Packet Data Services	Yes
35-36	Location Services	Yes
54	Markov Service Option (MSO)	No
55	Loop back Service Option (LSO)	No
32798	Markov Calls (RS1)	Yes
32799	Markov Calls (RS2)	Yes

# Appendix B: References

## Sierra Wireless documents

These documents are (or will be) available in the PCI-Express Mini Card Universal Development Kit:

- *MiniCard Development Kit Quick Start Guide* (document 2130705)
- *MiniCard Hardware Integration Guide* (document 2130114)
- *MiniCard Software Integration Guide* (document 2130759)
- *AT Command Reference* (document 2130620)
- *SDK API Reference* (document 2131051)
- *CnS Reference* (document 2130754)

The following documents are available separately:

- *EMConnect Guide* (document 2131177)

## TIA/EIA standards

TIA standards are available at [www.tiaonline.org](http://www.tiaonline.org).

1. TIA/EIA/IS-2000.1 through .6. **cdma2000<sup>®</sup> Standards for Spread Spectrum Systems. Release 0.** April 2000.
2. TIA/EIA/IS-2000.1-1 through .6-1. **cdma2000<sup>®</sup> Addendum 1.** April 2000.
3. TIA/EIA/IS-2000.1-2 through .6-2. **cdma2000<sup>®</sup> Addendum 2.** June 2001.
4. TIA/EIA-95-B. **Mobile Station-Base Station Compatibility Standard for Dual-Mode Spread Spectrum Systems.** December 4, 1998.
5. TIA/EIA/IS-707-A. **Data Service Options for Wideband Spread Spectrum Systems.** March 2000.
6. TIA/EIA/IS-134. **Facsimile Digital Interfaces - Amendments to [TIA/EIA-592](#) to Support ITU-T T.30-1993.** October 1994.
7. TIA/EIA-592. **Asynchronous Facsimile DCE Control Standard - Service Class 2.** April 1998.
8. TIA/EIA-617. **Data Transmission Systems and Equipment for In-Band DCE Control.** January 1996.

9. TIA/EIA/IS-733-1. **High Rate Speech Service Option 17 for Wideband Spread Spectrum Communication Systems.** September 1999.
10. TIA/EIA/IS-736. **Recommended Minimum Performance Standard for the High Rate Speech Service Option 17 for Spread Spectrum Communication Systems.** August 2000.
11. TIA/EIA/IS-127-2. **Enhanced Variable Rate Codec, Speech Service Option 3 for Wideband Spread Spectrum Digital Systems - Addendum 2.** September 1999.
12. TIA/EIA/IS-718. **Minimum Performance Specification for the Enhanced Variable Rate Codec, Speech Service Option 3 for Spread Spectrum Digital Systems.** July 1998.
13. TIA/EIA-637-B. **Short Message Service for Wideband Spread Spectrum Cellular Systems.** January 2002.
14. TIA/EIA/IS-683-A. **Over-the-Air Service Provisioning of Mobile Stations in Spread Spectrum Systems.** June 1998.
15. TIA/EIA/IS-835-A. **Wireless IP Network Standard.** May 2001.
16. TIA/EIA/IS-870. **Test Data Service Option (TDSO) for cdma2000<sup>®</sup> Spread Spectrum Systems.** 2001.
17. TIA/EIA/IS-98D/E. **Recommended Minimum Performance Standards for Dual-Mode Spread Spectrum Mobile Stations.**
18. TIA/EIA/IS-866. **Recommended Minimum Performance Standards for cdma2000<sup>®</sup> High Rate Packet Data Access Terminal.**
19. TIA/EIA-126-D. **Mobile Station Loop back Service Options Standard.** 2001.
20. TIA/EIA TSB 58-C. **Administration of Parameter Value Assignments for TIA/EIA Wideband Spread Spectrum Standards.** May 2000.
21. TIA/EIA TSB 50. **User Interface for Authentication Key Entry.** March 1993.
22. TIA/EIA/IS-801.1. **Location Service Standard for Dual-Mode Spread Spectrum Systems.** March 2001.

23. C.S0031-0. **Signaling Conformance Tests for CDMA2000® Spread Spectrum Systems, Ballot Resolution.** Version 3GPP2 TSG- C v2.0
24. C.S0036-0. **Recommended Minimum Performance Specification for C.S0022-0 Spread Spectrum Mobile Stations.** 3GPP2 C.S0036-0 v1.0.
25. TIA/EIA/IS-J-STD-036. **Enhanced Wireless 9-1-1 Phase II.** January 2001.
26. TIA/EIA/IS-856. **cdma2000® High Rate Packet Data Air Interface Specification.** November 2000.

## CDG standards

1. CDG 22. **Stage 2 Interoperability Tests (TIA/EIA/IS-95A).** Ver. 8.0. September 2000.
2. CDG 53. **Stage 2 Interoperability Tests (TIA/EIA-95-B).** Ver. 2.0. June 2000.
3. CDG 57. **Stage 2 Interoperability Tests (TIA/EIA/IS-2000).** Ver. 0.7. February 2001.
4. CDG 36. **Markov Service Options for Wideband Spread Spectrum Systems Communications Systems.** March 11, 1996.
5. CDG 64. **CDG Stage 3 Testing for CDMA2000®.** Ver. 1.0. August 2002.

## Agency standards

1. [FCC 47 CFR - Part 15.](#) **Radio Frequency Devices.** January 2001.
2. [FCC 47 CFR - Part 22.](#) **Cellular Radiotelephone Services.** October 1998.
3. [FCC 47 CFR - Part 24.](#) **Personal Communications Services.** October 1998.
4. Industry Canada ICES-003. **Interference-Causing Equipment Standard - Digital Apparatus.** November 22, 1997.
5. Industry Canada RSS-132. **Cellular Telephones Employing New Technologies Operating in the Bands 824-849 MHz and 869-894 MHz.** Issue 2. September 2005.
6. Industry Canada RSS-133. **2 GHz Personal Communications Services.** September 25, 1999.

7. IEC 61000-4-2. **Electrostatic Discharge Immunity Test.**
8. JESD22-A114-B. **+/- 1 kV Human Body Model.**
9. JESD22-C101. **+/- 125 V Charged Device Model.**
10. FCC 47 CFR - Part 2. **Frequency allocations and radio treaty matters; general rules and regulations.**

## **Other standards**

1. **Openwave\_IOTA\_Protocol\_v2.0\_Specifications\_doc\_v2.04.**  
February 2002.
2. **PCI Express Mini Card Specification.** Ver. 1.2. [www.pcisig.com](http://www.pcisig.com).
3. **Universal Serial Bus Specification.** Revision 2.0.  
[www.usb.org/developers/docs](http://www.usb.org/developers/docs).



# Appendix C: Acronyms

**Table 41: Acronyms**

Acronym or term	Definition
1xEV-DO	Single Carrier (1X) EVolution – Data Only. A high-speed standard for cellular packet data communications. Supports Internet connections with data rates up to 3.1 Mbps (downlink from the network) and 1.8 Mbps (uplink to the network). Average data rates are roughly: for Rev. A: 600-1300 kbps (downlink from the network) and 300-400 kbps (uplink to the network); for Rev. 0: 400-700 kbps (downlink from the network) and 40-80 kbps (uplink to the network). Actual speed depends on the network conditions. Compare to 1X.
1X	Single Carrier (1X) Radio Transmission Technology. A high-speed standard for cellular packet data communications. Supports Internet connections with data rates up to 153 kbps (simultaneously in each direction—downlink and uplink). Actual speed depends on the network conditions. Compare to 1xEV-DO.
API	Application Programming Interface
AT	A set of modem commands, preceded by “AT,” originally developed by Hayes, Inc. for their modems. The structure (but not the specific commands, which vary greatly from manufacturer to manufacturer) is a de facto modem industry standard.
CDG	CDMA Development Group
CDMA	Code Division Multiple Access. A wideband spread spectrum technique used in digital cellular, personal communications services, and other wireless networks. Wide channels (1.25 MHz) are obtained through spread spectrum transmissions, thus allowing many active users to share the same channel. Each user is assigned a unique digital code, which differentiates the individual conversations on the same channel.
cdmaOne	The IS-95 CDMA standard developed by QUALCOMM Inc.
CnS	Sierra Wireless proprietary Control and Status language interface
DCE	Data Communications Equipment
EIA	Electronics Industry Association
ERP	Effective Radiated Power
ESN	Electronic Serial Number—The unique first-generation serial number assigned to the MC5728V Mini Card for use on the wireless network. Compare to MEID.
FCC	Federal Communications Commission. The U.S. federal agency that is responsible for interstate and foreign communications. The FCC regulates commercial and private radio spectrum management, sets rates for communications services, determines standards for equipment, and controls broadcast licensing. Consult <a href="http://www.fcc.gov">www.fcc.gov</a> .

Acronym or term	Definition
firmware	Software stored in ROM or EEPROM; essential programs that remain even when the system is turned off. Firmware is easier to change than hardware but more permanent than software stored on disk.
FSN	Factory Serial Number—A unique serial number assigned to the MC5728V Mini Card during manufacturing.
GPS	Global Positioning System A system that uses a series of 24 geosynchronous satellites to provide navigational data.
IOTA	Internet Over The Air—an automated feature, supported by some service providers, to perform account setup for you by making a connection to the CDMA network and using a secure Internet connection to download account parameters to your device.
IS	Interim Standard. After receiving industry consensus, the TIA forwards the standard to ANSI for approval.
kbps	kilobits per second – Actually 1000, not 1024, as used in computer memory size measurements of kilobytes.
LED	Light Emitting Diode. A semiconductor diode that emits visible or infrared light.
Mbps	Millions of bits per second, or Megabits per second.
MEID	Mobile Equipment Identifier—The unique second-generation serial number assigned to the MC5728V Mini Card for use on the wireless network. Compare to ESN.
NAM	Number Assignment Module Semi-permanent information stored in the modem's non-volatile memory, including the modem's Mobile Identification Number, the station class mark, carrier code, and other cellular identifiers. Essentially the phone number, it should be treated as confidential information and should not be disclosed to anyone other than the cellular service provider.
NV	Non-Volatile (memory)
OEM	Original Equipment Manufacturer A company that manufactures a product and sells it to a reseller.
OTAPA	Over the Air Parameter Administration
OTASP	Over the Air Service Provisioning
PCS	Personal Communications Services A cellular communication infrastructure that uses a different frequency range than AMPS.
PPP	Point to Point Protocol. An alternative communications protocol used between computers, or between computers and routers on the Internet. PPP is an enhanced SLIP.
PRI	Product Release Instructions—a file that contains the settings used to configure modems for a particular service provider, customer, or purpose.

Acronym or term	Definition
QAM	Quadrature Amplitude Modulation. This form of modulation uses amplitude, frequency, and phase to transfer data on the carrier wave.
RF	Radio Frequency
RLP	Radio Link Protocol. This protocol improves the error characteristics of the wireless link, thereby reducing the need for transport layer retransmission due to lost data.
Rx	Receive
SAR	Specific Absorption Rate
SKU	Stock Keeping Unit—identifies an inventory item: a unique code, consisting of numbers or letters and numbers, assigned to a product by a retailer for purposes of identification and inventory control.
SMS	Short Message Service. A feature that allows users of a wireless device on a wireless network to receive or transmit short electronic alphanumeric messages (up to 160 characters, depending on the service provider).
TIA/EIA	Telecommunications Industry Association / Electronics Industry Association. Telecommunications Industry Association – A standards setting trade organization, whose members provide communications and information technology products, systems, distribution services and professional services in the United States and around the world. Consult <a href="http://www.tiaonline.org">www.tiaonline.org</a> .
Tx	Transmit
USB	Universal Serial Bus

# Index

## 1

- 1/8 Rate Traffic Channel Gating, 23
- 10 ms Frame size, 23
- 13QCELP vocoder, 25
- 1X
  - overview, 17
  - data current, 47
  - support, 22
- 1X High Speed Packet Data Services, 60
- 1X/1xEV Hybrid Terminal Operation, 23
- 1xEV-DO
  - overview, 18
  - data current, 48
  - support, 23

## 5

- 5 ms Frame size, 23

## A

- A type code, 33
- Access Entry Handoff, 21
- Access Probe Handoff, 21
- accessories, 15
- Acknowledge Messaging, 25
- acronyms, 65
- Advanced Forward Link Trilateration (AFLT), 27
- AFLT, 27
- agency certifications, 29
- agency standards, 63
- Air Interface as defined by IS-856, 23
- Air Interface Tool (CAIT), 51
- aircraft, 2
- A-Key Exchange, 26
- A-Law companding algorithm, 39
- algorithms, companding, 39
- AMPS Improvements, 21
- Analog Fax, 24
- analog interface, 37
- Analog Mode SMS, 25

## antenna

- diversity, specifications, 45
- GPS, specifications, 46
- main, specifications, 44
- RF connector, 43
- Asynchronous Data and Fax at 9.6 kbps and 14.4 kbps, 24
- Asynchronous Data Service, 60
- Asynchronous facsimile DCE Control Standard, 24
- AT Command Set, 24
- audio files, 51
- audio interface, PCM, 39
- audio output, differential, 37
- audio transmit path performance
  - characteristics
  - microphone, 38
- auxiliary analog-to-digital input, 37
- Auxiliary voltage input, 32, 37
- AUXV1, 32, 37

## B

- band class, 20
- bands supported, 44
- bandwidth, additional, 17
- Basic Variable Rate Voice Service, 60
- batch revision number, 55
- Bearer Selection Table Provisioning, 27
- block diagram, 31
- Bootstrap Provisioning, 27
- Broadcast Control Channel, 23
- Broadcast Messaging, 25

## C

- C.S0031, 29
- C.S0032, 29
- CAIT, 51
- call origination, 14
- Calling Name Presentation, 21
- CDG
  - CDG 1, 2, and 3, 58
  - CDG 22, 29

- CDG 36, 28
- CDG 53, 29
- CDG 64, 29
- list of standards, 63
- CDMA
  - overview, 17
  - Air Interface Tool (CAIT), 51
  - certification requirements, 28
  - data services, 24
  - High Speed Packet Data, 24
  - Short Message Service. *See* SMS
  - voice services, 25
- certification requirements, 28
- change history, 11
- Channel Assignment into Soft Handoff, 21
- channels, fundamental and supplemental, 17
- circuit-switched data, 15, 17
- CNAP, 21
- CNS message categories, 50
- companding algorithms, 39
- compliance, standards, 20
- Connected State Off-Frequency Neighbor Search, 23
- consumption, power, 47
- contact information, 4
- control channel
  - Broadcast, 23
  - DCCH, 22
  - Forward Common, 23
  - interface, 50
  - Reverse Common, 23
- control interface, 34
- control signal DC electrical specifications, 35
- convolutional encoding/decoding, 23
- coverage, radio, restoration - wakeup host upon, 35
- CSD (circuit-switched data), 15, 17
- CTS, 33
- current
  - data, 47
  - leakage, 48
  - maximum peak – call connected, 48
  - maximum peak - operational, 48
  - standby, 12, 47

- talk, 12

## D

- data channel interface, 49
- data current, 47
- data rate, maximum, 21
- Data rates up to 3.1 Mbps, 24
- data services, 24
- date code, manufacturing, 55
- DC electrical specifications, 35, 36
- DC power consumption, 47
- DCCH, 22
- Dedicated Control Channel, 22
- definitions, 65
- Development Kit, 15
- diagnostic channel, 49
- diagram, block, 31
- diagrams of module, 12, 53
- differential line-level
  - audio, 37
  - microphone, 14
- digital interface, 35
- digital IO, 32
- digital signal DC electrical specifications, 36
- dimensions, 53
- DIO I/O pins, 35
- Directed Test tool, 51
- disable the module from transmitting, 35
- diversity
  - antenna, 45
  - receive, 43
- documents, reference, 61
- drop test, 52
- Dual RF Receive Diversity, 23

## E

- E911, 14
- E911 Phase II Position Determination Compliance, 27
- echo cancellation, 14
- EIA
  - list of standards, 61
  - 126-D, 28
  - 592, 24
  - 617, 24

- 637-B, 25
- 95B, 21, 29
- IS-134, 24
- IS-2000, 21
- IS-683-A, 26
- IS-707.3, 49
- IS-801.1, 27
- IS-835-A, 24
- IS-856, 23
- IS-870, 28
- IS-95A, 29
- IS-98D, 28
- IS-J-STD-036, 27
- TSB-50, 28
- TSB-58-C, 28
- electrical specifications, 12, 30
- electronic serial number (ESN), 55
- electrostatic discharge, 52
- EMConnect, 14
- emissions, 29
- Enhanced Access Channel, 23
- Enhanced Variable Rate Voice Service, 60
- environmental specifications, 13, 52
- ERP, 56
- ESD, 52
- ESN (electronic serial number), 55
- EVRC vocoder, 25

## F

- Facsimile Digital Interfaces, 24
- Factory Serial Number (FSN), 55
- fax, 24, 60
- FCC, 29, 56
- FCC E911 Phase II Position Determination Compliance, 27
- FCH, 22
- figures, list of, 10
- firmware upgrades, 4
- form factor, 52
- Forward Common Control Channel, 23
- F-QPCH, 22
- FSN (Factory Serial Number), 55
- fundamental channel, 17, 22

## G

- glossary, 65
- GPS
  - specifications, 46
  - specifications, antenna, 46
- GPS sensitivity, 45
- ground specifications, 34
- Group 3 Facsimile, 60

## H

- Handoff Between IS-2000 and IS-856 Systems, 23
- hazards, 2
- headset, 15
- high level input voltage
  - control signal, 35
  - digital signal, 36
- high output voltage
  - control signal, 35
  - digital signal, 36
- High Rate Voice Service, 60
- High Speed Broadcast Services, 23
- High Speed Packet Data, 24, 60
- Hopping Pilot Beacon, 21
- host connector, 31
- host interface, 30, 31
- host wakeup, 35
- HSBS, 23
- HTTP and SSL Support (Download Agent), 27
- humidity, relative, 52
- Hybrid Mode Standby current, 47

## I

- I type code, 33
- I/O
  - DIO pins, 35
- IC (Industry Canada), 29
- ICES-003, 29
- In-Band DCE Control, 24
- incoming call notification, 14
- Industry Canada, 29
- input voltage
  - control signal, 35
  - digital signal, 36

input, microphone, 37  
input/output - DIO pins, 35  
integration requirements, 58  
interface  
  list, 13  
  analog, 37  
  control, 34  
  control channel, 50  
  data channel, 49  
  digital, 35  
  host, 31  
  PCM, 14, 39  
  software, 49  
  USB, 34, 49  
Internet Over The Air, 26  
interoperability standards, 29  
IOTA, 26  
IS-127-2, 25  
IS-134, 24  
IS-2000  
  data current, 47  
  data rates, 14  
  interoperability tests, 29  
  standby current, 47  
  support, 21  
IS-553-A, 21  
IS-683, 26  
IS-683-A, 26  
IS-683-A/B, 27  
IS-707.3, 49  
IS-707-A, 24  
IS-718, 25  
IS-733-1, 25  
IS-736, 25  
IS-801.1, 27  
IS-835-A, 24  
IS-856  
  1xEV-DO data current, 48  
  features supported, 23  
  data rates, 14  
IS-866, 28  
IS-870, 28  
IS-890, 23  
IS-95  
  circuit-switched features, 15  
  standby current, 47

IS-95A  
  interoperability tests, 29  
  overview, 17  
IS-95B Wireless Local Loop, 21  
IS-98D, 13, 28  
IS-J-STD-036, 27

## L

label, 54  
LBS. *See* GPS  
leakage current, 48  
LED  
  driver, 33, 34  
  output, 30  
length of module, 53  
liability, limitation of, 3  
Licensed transmission, 29  
limitation of liability, 3  
Linear companding algorithm, 39  
Location Services, 60  
Location-Based Services. *See* GPS  
logical interfaces, 49  
Loop back Service Option (LSO), 60  
low level input voltage  
  control signal, 35  
  digital signal, 36  
low level output voltage  
  control signal, 35  
  digital signal, 36  
LSO (Loop back Service Option), 60

## M

MABO, 23  
main antenna, 44  
manufacturing date code, 55  
manufacturing test support, 51  
Markov Calls, 60  
Markov Service Option (MSO), 28, 60  
max high output voltage, 35  
maximum data rate, 21  
maximum operational peak current, 48  
maximum peak current – call connected,  
  48  
MDR, 21, 24  
mechanical specification, 52  
MEID (Mobile Equipment Identifier), 55

- memory, 51
- memory, non-volatile (NV), 51
- messaging. *See* SMS
- MIC1\_N, 37
- MIC1\_P, 37
- microphone
  - audio transmit path performance characteristics, 38
  - input, 14, 37
  - pins, 31
- MIME Parser / Assembler, 27
- m-Law companding algorithm, 39
- MMC XML and MIME Parser / Assembler, 27
- MO SMS, 25
- Mobile Assisted Burst Operation, 23
- Mobile Assisted Hard Handoff, 21
- Mobile calculated position, 27
- Mobile Equipment Identifier (MEID), 55
- Mobile initiated, PDE calculated position, 27
- Mobile IP, 24
- Mobile Originated SMS, 25
- mobile station class, 20
- Mobile Station Loop back, 28, 60
- Mobile Terminated SMS, 25
- Module OFF leakage current, 48
- Module Reset Input, 32
- MSO (Markov Service Option), 60
- MT SMS, 25
- MUX mode, USB interface, 49

## N

- NAM Lock, 26
- NAM Parameter Download, 26
- NDIS, 13
- Network Directed System Selection, 21
- Network Initiated Provisioning using WAP Push, 27
- new in this document, 11
- non-MUX mode, USB interface, 49
- non-volatile memory (NV), 51
- notification, incoming call, 14
- NV (non-volatile memory), 51

## O

- O type code, 33
- ordering information, 16
- Orthogonal Transmit Diversity, 23
- OTAPA NAM Lock, 26
- OTASP, 26
- OTD, 23
- output voltage
  - control signal, 35
  - digital signal, 36
- Over-the-Air Service Administration, 60
- Over-The-Air Service Provisioning, 26

## P

- P\_REV 6, 22
- P\_REV 7, 22
- P\_REV support, 20
- Packet Data Service
  - High Speed, 60
  - IP Stack Only, 60
  - Relay Mode, in, 23
  - support, 24
- packet mode features, 14
- parametric performance, 28
- patents, 3
- PCI Express Mini Card Specification, 64
- PCM
  - interface, 14, 39
  - signals, 33, 35
- PCM\_CLK, 40
- PCM\_DIN, 40
- PCM\_DOUT, 40
- PCM\_SYNC, 40
- PD type code, 33
- PDE initiated, PDE calculated position (Mobile terminated request), 27
- PDSM. *See* GPS
- peak current, maximum – call connected, 48
- peak current, maximum operational, 48
- performance
  - RF, 45
- physical features, 12
- pin assignments, 31
- Point-to-Point Messaging, 25



position location, 27  
 power  
   consumption, 47  
   source, 48  
   specifications, 34  
 Power-Up Function, 21  
 Pre-arrangement for incoming Async data or fax, 24  
 Preferred Roaming List (PRL) Download, 26  
 PREV support, 20  
 PRI, 51  
 Priority Access and Channel Assignment, 21  
 PRL Download, 26  
 Product Support Tool, 51  
 Protocol Capability Messaging, 26  
 protocol revision support, 20  
 PST, 51  
 PU type code, 33  
 PUF, 21

## Q

QNC, 24  
 QOF, 22  
 QoS (Quality of Service) Enhancements, 24  
 Quality of Service (QoS) Enhancements, 24  
 Quality of Service Negotiation, 23  
 Quasi Orthogonal Functions, 22  
 Quick Net Connect, 24  
 Quick Paging Channel, 22  
 QXDM, 51

## R

radio configurations, 21  
 radio coverage restoration, wakeup host upon, 35  
 Radio Link Protocol, 24  
 Reassembly of Multiple IOTA Trigger Messages, 27  
 Re-Authenticate Messaging, 26  
 receive diversity, 43  
 references, 61  
 regulatory agency compliance testing, 29

regulatory approvals, 56  
 relative humidity, 52  
 Release A, 22  
 reset pin, 32  
 Reverse Common Control Channel, 23  
 Reverse Pilot Channel, 22  
 Reverse Pilot Gating, 23  
 revision history, 11  
 RF  
   performance, 45  
 RF specifications, 13, 43  
 RI, 32, 34  
 Ring Indicator, 32, 34  
 ring tones, 51  
 ring, wakeup host upon, 35  
 RLP, 24  
 RLP2, 24  
 RLP3, 24  
 R-PICH, 22  
 RSS-132, 29  
 RSS-133, 29  
 RTS, 33  
 RXD, 33

## S

safety, 2  
 Sales Desk, 4  
 SAR, 56  
 SCH, 22  
 SDK, 13  
 sensitivity  
   GPS, 45  
 separation distance, 56  
 serial number, electronic (ESN), 55  
 serial number, factory (FSN), 55  
 Service Category Programming Teleservice, 25  
 Service Option support, 25, 60  
 shock, 52  
 Short Data Bursts, 23  
 Short Message Service. *See* SMS  
 SIA/PDE, 27  
 silent retry call origination protocol, 14  
 Simple IP, 24  
 Simultaneous forward link and reverse link up to 153 kbps, 23

- Simultaneous Maximum Data rates on
  - Forward and Reverse Channels, 22
- Simultaneous Voice and Data, 23
- SKU, 55
- Slotted Mode (Sleep) Operation, 23
- Slotted Mode Timer, 23
- SMS
  - compliance with TIA/EIA-637-B, 25
  - features, 15
  - features supported, 25
  - service option support, 60
  - wakeup host upon, 35
- Snap Track Sensor Interface Application and Position Determination Entity, 27
- SO (Service Option) support, 60
- software interface, 49
- speaker
  - output, 14, 37
  - pins, 32
- specifications
  - summary, 12
  - electrical, 30
  - environmental, 52
  - GPS, 46
  - GPS antenna, 46
  - mechanical, 52
  - RF, 43
- SPK1\_N, 37
- SPK1\_P, 37
- spurious harmonics, 56
- standards
  - agency, 63
  - CDG, 63
  - compliance, 20
  - interoperability, 29
  - TIA/EIA, 61
  - other, 64
- standby current, 12, 47
- storage, memory, 51
- STU-III, 24
- supplemental channel, 17, 22
- Supplemental Code Channel Loop back, 60
- Supplemental Code Channels, 21
- supply voltage
  - control signal, 35

- digital signal, 36
- support
  - features, 15
  - Sierra Wireless, provided by, 57
  - technical, 4
  - tools, 51
- Support for Test Application Specification, 23
- system block diagram, 31

## T

- tables, list of, 8
- talk current, 12
- TDD, 25
- TDSO, 28, 60
- technical support, 4
- temperature, 52
- terms, 65
- Test Application Specification, 23
- Test Data Service Option (TDSO), 28, 60
- text messaging. *See* SMS
- thermal consideration, 52
- thickness of module, 53
- TIA/EIA
  - list of standards, 61
  - 126-D, 28
  - 592, 24
  - 617, 24
  - 637-B, 25
  - 95B, 21, 29
  - IS-127-2, 25
  - IS-134, 24
  - IS-2000, 21
  - IS-683-A, 26
  - IS-707.3, 49
  - IS-718, 25
  - IS-733-1, 25
  - IS-736, 25
  - IS-801.1, 27
  - IS-835-A, 24
  - IS-856, 23
  - IS-870, 28
  - IS-95A, 29
  - IS-98D, 28
  - IS-J-STD-036, 27
  - TSB-50, 28

- TSB-58-C, 28
- timing diagrams, 40, 42
- trademarks, 4
- Traffic Channel Control Hold, 23
- transmit disable, 35
- TTY, 25
- turbo encoding/decoding, 22, 23
- TXD, 33
- type code, 33

## U

### UART

- Clear to send, 33, 35
- Receive data, 33, 36
- Request to send, 33, 36
- Transmit data, 33, 36

UDM, 51

unit label, 54

Universal Diagnostic Monitor, 51

Universal Product Support Tool, 51

Update tool, 51

UPST, 51

### USB

- interface, 34, 49
- pins, 32
- support, 13

User Interface for Authentication Key  
Entry, 28

User NAI Profiles and CDMA Objects, 27

## V

V type code, 33

VCC reference, 32

vendor logo, 55

vibration, 52

vocoder, 25

voice features, 14

Voice Mail Notification, 25

Voice Service Option standards, 25

voice services, 25

voltage

- control signal, 35

- digital signal, 36

## W

wake host upon certain events, 35

Wakeup Enable, 13, 35

warranty, 15

WBXML Parser / Assembler, 27

weight of module, 53

width of module, 53

Wireless Application Teleservice, 25

Wireless Disable, 30, 32, 34

Wireless Local Loop, 21

Wireless Messaging Teleservice, 25

Wireless Paging Teleservice, 25

WLL, 21

## X

XML, MMC, and MIME Parser /  
Assembler, 27