

DATA SHEET

Version: 1.14

Dated: 2012-08-08

Date	Version	Modified Items	publisher
2012.08.08	1.14	Increase 0x82 PS register & ALS min. sensitivity	Lucas
2012.07.06	1.13	Modify DC Characteristics	Lucas
2012.06.27	1.12	Increase DC Characteristics	Lucas
2012.06.18	1.11	Modify application circuit.	Lucas
2012.05.11	1.10	Increase ALS Dynamic Range. Modify ALS max detect range.	Lucas
2012.04.18	1.09	Increase I2C sequential Read Diagram. Increase SW Reset register, and SW-Reset request.	Lucas
2012.03.27	1.08	Modify PS Interrupt State Diagram and add limitation of register 0x08 bit 0	Lucas
2012.02.17	1.07	Modify I2C ACK Diagram (from H to L) to match IC design	Lucas
2012.01.13	1.06	Add PS Interrupt State Diagram	YL
2011.12.01	1.05	Modify Application Circuit	YL
2011.11.17	1.04	Add Tape and Reel Diagram Add ESD spec. Modify Description and Feature	YL
2011.08.26	1.03	Add Optical Center Relative to Package Center Diagram Add Reference PCB Layout Diagram	YL
2011.08.01	1.02	Modify register "GAIN_ALS" from 2 bits to 1 bit Modify reflow figure	YL
2011.07.12	1.01	Modify Application Circuit Modify Pin Description Add Reflow item	YL
2011.06.16	1.0	New Released.	WS

Note! Information provided within this document is subject to change without notice. Sitronix reserves the right to change the product design without notice to its users.

1. OVERVIEW

Description

The STK3101-90H is an integrated ambient and infrared light to digital converter with a built-in IR LED driver and I2C Interface. This device provides not only ambient light sensing to allow robust backlight/display brightness control but also infrared sensing to allow proximity estimation featured with interrupt function.

For ambient light sensing, the STK3101-90H incorporates a photodiode, timing controller and ADC in a single chip. The excellent spectral response is designed to be close-to human eye. The STK3101-90H is suitable for detecting a wide range of light intensity environment. The maximum detecting light intensity is 32K Lux.

For proximity sensing, the STK3101-90H also incorporates a photodiode, timing controller and ADC in the same chip. The best spectral sensitivity is around 850nm used to sense the infrared light. The STK3101-90H provides programmable sink current setting to drive IR LED and employs a noise cancellation scheme to highly reject unwanted ambient IR noise.

The STK3101-90H has excellent temperature compensation, robust on-chip refresh rate setting without external components. Software shutdown mode control is provided for power saving application. The STK3101-90H operating voltage range is 2.5V to 3.6V.

Feature

- Convert light intensity to 16-bit digital data format
- Excellent ambient light sensing response: intuitive close to human eye, not a conventional approximation through the calculation between clear and IR sensing output
- Excellent temperature compensation: -40 to 85°C
- High detecting dynamic range
- Standard I²C protocol interface
- Immunity to 50Hz/60Hz fluorescent light flicker
- Flicker detection for light source.
- Software shutdown mode control
- Maximum detecting ambient light intensity 57K Lux
- Ambient IR noise cancellation during proximity sensing
- Adjustable IRLED drive current, 100mA and 200mA
- Package: OPLGA 2.35x1.8x1.0(mm)
- Lead-free package (RoHS compliant)

Applications

- Mobile Phone, Smart-phone, PDA

2. FUNCTION BLOCK

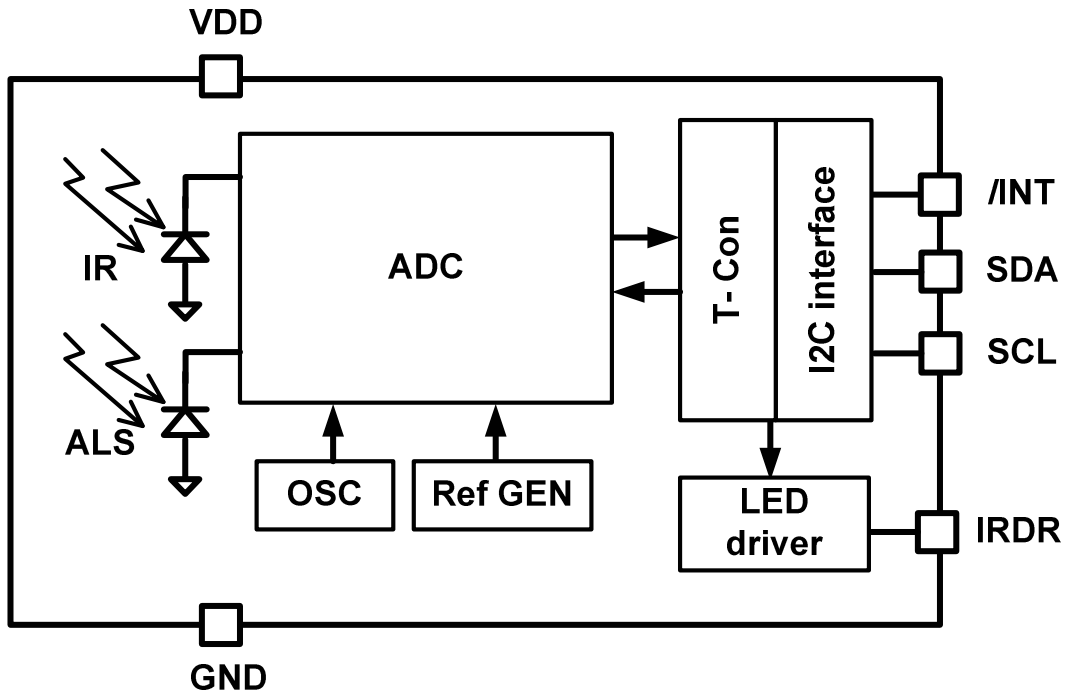

3. PINOUT DIAGRAM

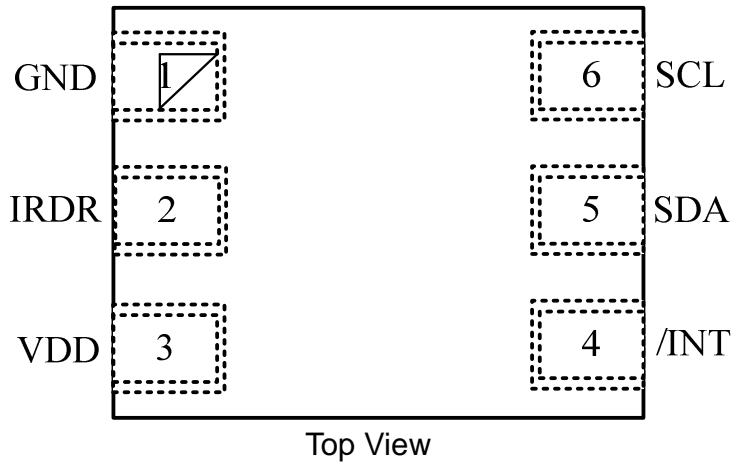

4. PIN DESCRIPTION

Pin No.	Pin Name	Dir.	Pin Function
1	GND	GND	Ground. The thermal pad is also connected to the GND pin.
2	IRDR	I	IR LED driver pin connecting to the cathode of the external IR LED. The source current of the IR LED driver can be programmed through I2C.
3	VDD	PWR	Power supply: 2.5V to 3.6V.
4	INT	O	Interrupt pin; LO for interrupt alarming. The INT pin is an open drain.
5	SDA	B	I2C serial data line.
6	SCL	I	I2C serial clock line.

Direction denotation:

O	Output	GND	Ground
I	Input	B	Bi-direction
PWR	Power		

5. ELECTRICAL SPECIFICATIONS

Absolute Maximum Ratings

Symbol	Parameter	Min.	Typ.	Max.	Unit
VDD	Supply voltage	-0.3	—	3.6	V
Ta	Operation temperature	-40	—	85	°C
Ts	Storage temperature	-40	—	85	°C

NOTE: All voltages are measured with respect to GND

Recommended Operating Conditions

Symbol	Parameter	Min.	Typ.	Max.	Unit
VDD	Supply voltage	2.5	—	3.6	V
f _{I2C}	Clock frequency of I2C	—	—	400	KHz
Ta	Operation temperature	-40	—	85	°C

NOTE: All voltages are measured with respect to GND

Symbol	Parameter	Max.	Unit
ESD	Electrostatic discharge protection	4 (HBM)	kV
		200 (MM)	V
		100 (Latch Up)	mA

NOTE: All voltages are measured with respect to GND

5.1 DC Characteristics

Electrical and Optical specifications

Symbol	Parameter	Condition	Min.	Typ.	Max.	Unit
VDD	Supply Voltage		2.5		3.6	V
VI2C	I2C Supply Voltage		1.7		3.6	V
I _{CC}	Supply current	VDD=2.8V, 01h=09h=0x00		90		μA
I _{LEDC}	Supply current of IR LED	Note 1		100		mA
I _{SD}	Shutdown current	VDD=2.8V, 01h=09h=0x01		1		μA
λ _{p1}	Peak sensitivity wavelength for ALS	Note 2		550		nm
λ _{p2}	Peak sensitivity wavelength for PS	Note 2		850		nm
Data _{Dark}	ALS Dark offset	VDD=2.8V, 01h=0xC4h	0	1		Counts
ΔData/Data	ALS Count Output Variation	VDD=2.8V, 01h=0x00, White LED	224	280	336	Counts
Data _{PROX}	Proximity Measurement Result	VDD=2.8V, 09h=0x00, 850nm IR-LED	97	121	145	Counts
V _{IH}	Logic high, I ² C	VDD=2.8V	1.5		VDD	V
V _{IL}	Logic low, I ² C	VDD=2.8V	—		0.4	V
—	Detectable intensity		—		57671	Lux

Note 1: Power supply (V_{Anode}) is 2.8V and 01h=0x00, 09h=0x00 with R_L = 0Ω (R_L will be stated in sec. 12)

Note 2: Power supply (VDD) is 2.8V, halogen lamp light source and room temperature is 25°C.

5.2 Timing Chart

Characteristics of the SDA and SCL I/O

Symbol	Parameter	Standard Mode		Fast Mode		Unit
		Min.	Max.	Min.	Max.	
f_{SCLK}	SCL clock frequency	10	100	10	400	KHz
t_{HDSTA}	Hold time after (repeated) start condition. After this period, the first clock is generated	4.0	—	0.6	—	μs
t_{LOW}	LOW period of the SCL clock	4.7	—	1.3	—	μs
t_{HIGH}	HIGH period of the SCL clock	4.0	—	0.6	—	μs
t_{SUSTA}	Set-up time for a repeated START condition	4.7	—	0.6	—	μs
t_{HDDAT}	Data hold time	—	120	—	120	ns
t_{SUDAT}	Data set-up time	250	—	100	—	ns
t_r	Rise time of both SDA and SCL signals	—	1000	—	300	ns
t_f	Fall time of both SDA and SCL signals	—	300	—	300	ns
t_{SUSTO}	Set-up time for STOP condition	4.0	—	0.6	—	μs
t_{BUF}	Bus free time between a STOP and START condition	4.7	—	1.3	—	μs

Note 1: f_{SCLK} is the $(t_{SCLK})^{-1}$.

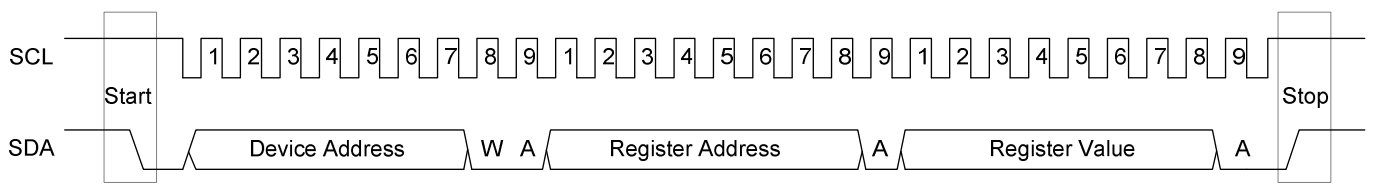
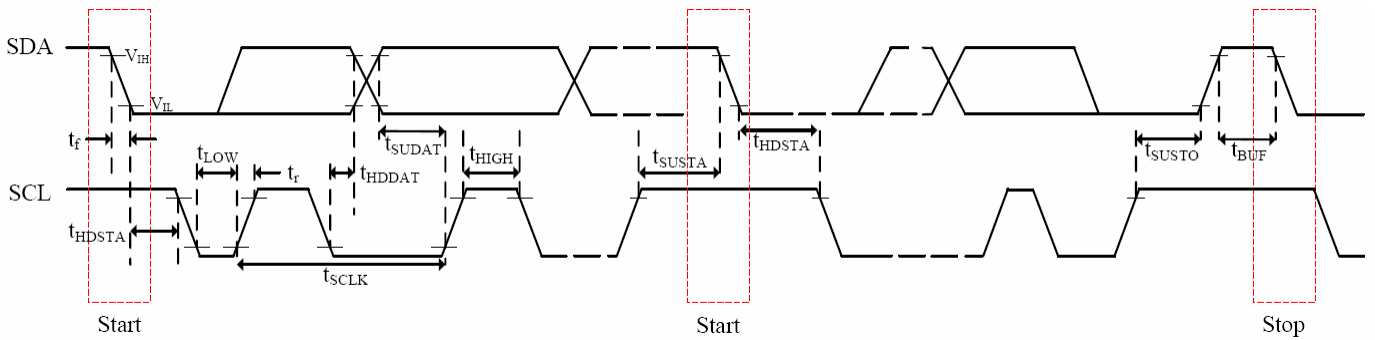

Write Command

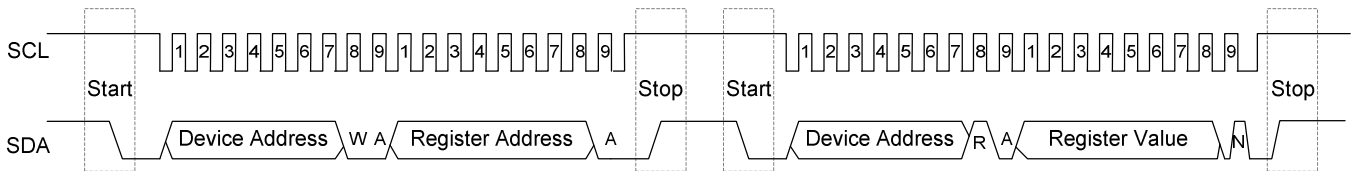

Read Data

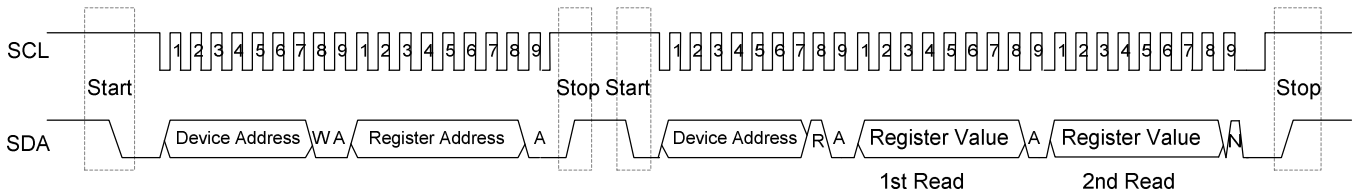

Sequential Read Data

6. PRINPICLE OF OPERATION

Digital Interface

STK3101-90H contains an eight 8-bit registers accessed via the I²C bus. All operations can be controlled by the command register. The sample command structure makes the user easy to program the operation setting and latch the light data from STK3101-90H. In timing chart, it is STK3101-90H I2C command format description for reading and writing operation between the host and STK3101-90H.

Slave Address

STK3101-90H provides the fixed slave address, 0x90. In following table, it describes the command setting.

ID Address	COMMAND ADDRESS	OPERATION
0x90	0x90	Write Command to STK3101-90H
	0x91	Read Data form STK3101-90H

Function Description

In the following table, there are 12 registers that are available in the STK3101-90H. The STK3101-90H has 16-bit resolution for ALS. The host first reads the data from the 0x02 register data and then reads the 0x03 register data to complete the word mode data collection. The STK3101-90H has 8-bit resolution for PS. The PS data register is in the register 0x0A. The following table summarizes their function.

ADDR	REG NAME	BIT								Default
		7	6	5	4	3	2	1	0	
01h	ALS CMD	Reserve d	GAIN0_ ALS	0	0	IT1_ ALS	IT0_ ALS	INT_ ALS	SD_ ALS	01h
02h	ALS DT1	DT15_ ALS	DT14_ ALS	DT13_ ALS	DT12_ ALS	DT11_ ALS	DT10_ ALS	DT9_ ALS	DT8_ ALS	00h
03h	ALS DT2	DT7_ ALS	DT6_ ALS	DT5_ ALS	DT4_ ALS	DT3_ ALS	DT2_ ALS	DT1_ ALS	DT0_ ALS	00h
04h	ALS THDH1	THDH15_ ALS	THDH14_ ALS	THDH13_ ALS	THDH12_ ALS	THDH11_ ALS	THDH10_ ALS	THDH8_ ALS	THDH7_ ALS	FFh
05h	ALS THDH2	THDH7_ ALS	THDH6_ ALS	THDH5_ ALS	THDH4_ ALS	THDH3_ ALS	THDH2_ ALS	THDH1_ ALS	THDH0_ ALS	FFh
06h	ALS THDL1	THDL15_ ALS	THDL14_ ALS	THDL13_ ALS	THDL12_ ALS	THDL11_ ALS	THDL10_ ALS	THDL9_ ALS	THDL8_ ALS	00h
07h	ALS THDL2	THDL7_ ALS	THDL6_ ALS	THDL5_ ALS	THDL4_ ALS	THDL3_ ALS	THDL2_ ALS	THDL1_ ALS	THDL0_ ALS	00h
08h	STA TUS	ID1	ID0	FLG_ PS	FLG_ ALS	0	0	0	0	00h
09h	PS CMD	INT_ CT RL	SLP1_ P S	SLP0_ P S	IRDR_ P S	IT1_ PS	IT0_ PS	INT_ PS	SD_ PS	01h
0Ah	PS DT	DT7_ PS	DT6_ PS	DT5_ PS	DT4_ PS	DT3_ PS	DT2_ PS	DT1_ PS	DT0_ PS	00h
0Bh	PS THDH	THDH7_ PS	THDH6_ PS	THDH5_ PS	THDH4_ PS	THDH3_ PS	THDH2_ PS	THDH1_ PS	THDH0_ PS	FFh
0Ch	PS THDL	THDL7_ PS	THDL6_ PS	THDL5_ PS	THDL4_ PS	THDL3_ PS	THDL2_ PS	THDL1_ PS	THDL0_ PS	00h

80h	SW Reset	SWRst7	SWRst6	SWRst5	SWRst4	SWRst3	SWRst2	SWRst1	SWRst0	00h
82h	PS Gain	GC_PS3	GC_PS2	GC_PS1	GC_PS0	PS_GS3	PS_GS2	PS_GS1	PS_GS0	x8h

ALS Command Register (01 hex)

1. GAIN_ALS: Bit 6. The Gain setting for sensitivity range selection of ALS can be adjusted via I2C. The following table lists the possible values of GAIN_ALS.

BITS 6 (BITS[3:2])	MAX DETECT RANGE (Lux)	LUX/LSB
0 (00)	57671	0.88
1 (00)	28836	0.44

2. IT_ALS: Bit 3 and 2. The STK3101-90H fundamental refresh timing of ALS can be tuned by IT_ALS. To cooperate with the ALS command register, (IT1_ALS :IT0_ALS), the designer has a very wide rang and flexible way to choose a refresh time for the system programming demand. In following table, STK3101-90H fundamental refresh timing, (IT1_ALS : IT0_ALS) → (0 : 0) =x1, is 1T, i.e. 100ms. The other related refresh timing in the table are all changed by comparing with the fundamental timing. As the following table, it is below showing the timing table that the system designer can have a flexible way for choosing the desired fresh timing to STK3101-90H.

BITS 3:2	RELATIVE REFRESH TIMING	REFRESH TIMING TABLE
00	1 T	100ms
01	2 T	200ms
10	4 T	400ms
11	8 T	800ms

Refresh Timing Table for ALS

BITS 6, BITS [3:2]	MAX DETECT RANGE (Lux)	LUX/LSB
0, 11	7208	0.11
1, 11	3604	0.055

3. INT_ALS: Bit 1. INT_ALS = 0, disable ALS interrupt. INT_ALS = 1, enable ALS interrupt.

BIT 1	OPERATION
0	ALS INT Disable
1	ALS INT Enable

4. SD_ALS: Bit 0. SD_ALS = 0, enable ALS. SD_ALS = 1, disable ALS.

BIT 0	OPERATION
0	ALS Shutdown Disable (ALS ON)
1	ALS Shutdown Enable (ALS OFF)

ALS Data Register (02 hex and 03 hex)

The STK3101-90H has two 8-bit read-only registers to hold the data from LSB to MSB for ADC of ALS. The most significant bit (MSB) is accessed at 02 hex, and the least significant bit (LSB) is accessed at 03 hex. For 16-bit resolution, the data is from DT0_ALS to DT15_ALS. The registers are refreshed after every conversion cycle.

ALS Threshold Register (04, 05, 06 and 07 hex)

An ALS interrupt event (FLG_ALS) is governed by the high and low thresholds in register 04, 05, 06, and 07hex (ALS_THDH1, ALS_THDH2, ALS_THDL1, and ALSTHDL2). The user write a high and low threshold value to these registers and the STK3101-90H will issue an ALS interrupt flag if the actual count stored in registers 02hex and 03hex are outside the user's programmed window. The user must write 0 to clear FLG_ALS.

Status Register (08 hex)

1. ID number; Bits 7 and 6. The ID number is 0b00 for STK3101-90H. This registers is read only.

2. PS Interrupt flag; Bit 5. This is the status bit of the interrupt for PS.

The bit is set to logic high when the interrupt thresholds have been triggered, and logic low when not yet triggered. Once triggered, INT pin stays low and the status bit stays high. Both interrupt pin and the status bit are cleared by writing "0".

BIT 5	OPERATION
0	Interrupt is cleared or not triggered yet
1	Interrupt is triggered

3. ALS Interrupt flag; Bit 4. This is the status bit of the interrupt for ALS.

The bit is set to logic high when the interrupt thresholds have been triggered, and logic low when not yet triggered. Once triggered, INT pin stays low and the status bit stays high. Both interrupt pin and the status bit are cleared by writing "0".

BIT 4	OPERATION
0	Interrupt is cleared or not triggered yet
1	Interrupt is triggered

4. Reserved for engineering mode

BITS 3:0	OPERATION
0000	To keep these bits be 0, don't use these bits

SW-Reset Register (80 hex)

The STK3101-90H has internal Power ON reset. But it is recommended to do SW-Reset after Power ON by writing any value to SW-Reset register (ex: 0x80h=0x01h). SW-Reset register will be auto cleared when reading this byte.

PS Gain Control Register (82 hex)

1. GC_PS: The setting is trimmed under test mode. Please keep the GC_PS trimming setting in application.

BITS 7:4	GC_PS[3:0]
----------	------------

2. PS_Gain Setting: Available setting is as below. The other PS Gain setting is not available.

BITS 3:0	PS_GS[3:0]
0101	PS Gain x 4
1001	PS Gain x 8
1101	PS Gain x 16

PS Command Register (09 hex)

1. Interrupt Control; Bit 7. This bit is used to control the interrupt mode.

BIT 7	OPERATION
0	Set /INT pin low if FLG_ALS or FLG_PS high (logical OR)
1	Set /INT pin low if FLG_ALS and FLG_PS high (logical AND)

2. PS sleep time: Bit 6, and 5. The proximity sleep time between IR LED pulses can be adjusted via I2C. The following table lists the possible values of SLP_PS.

BITS 6:5	PROXIMITY SLEEP TIME
00	10ms; sleep time between IR LED pulses is 10ms
01	30ms; sleep time between IR LED pulses is 30ms
10	90ms; sleep time between IR LED pulses is 90ms
11	270ms; sleep time between IR LED pulses is 270ms

3. Amplitude of IR sink current: Bit 4. This device provides current source to sink an external IR LED. The sink current can be programmed through IRDR_PS.

BIT 4	IRDR PIN SINK CURRENT
0	100mA current sink
1	200mA current sink

4. IT_PS: Bit 3 and 2. The STK3101-90H fundamental refresh timing of PS can be tuned by IT_PS. To cooperate with the PS command register, (IT1_PS :IT0_PS), the designer has a very wide rang and flexible way to choose a refresh time for the system programming demand. In following table, STK3101-90H fundamental refresh timing, (IT1_PS : IT0_PS) → (0 : 0) =x1, is 1T, i.e. 0.2ms. The other related refresh timing in the table are all changed by comparing with the fundamental timing. As the following table, it is below showing the timing table that the system designer can have a flexible way for choosing the desired fresh timing to STK3101-90H.

BITS 3:2	RELATIVE REFRESH TIMING	REFRESH TIMING TABLE
00	1 T	0.2ms
01	1.5 T	0.3ms
10	2 T	0.4ms
11	2.5 T	0.5ms

Refresh Timing Table for PS

5. INT_PS: Bit 1. INT_PS = 0, disable PS interrupt. INT_PS = 1, enable PS interrupt.

BIT 1	OPERATION
0	PS INT Disable
1	PS INT Enable

6. SD_PS: Bit 0. SD_PS = 0, enable PS. SD_PS = 1, disable PS.

BIT 0	OPERATION
0	PS Shutdown Disable (PS ON)
1	PS Shutdown Enable (PS OFF)

PS Data Register (0A hex)

The STK3101-90H has 8-bit read-only registers to hold the data for ADC of PS. The registers are refreshed after every conversion cycle.

PS Threshold Register (0B and 0C hex)

A proximity interrupt event (FLG_PS) is governed by the high and low thresholds in register 0Bhex and 0Chex respectively. The user write a high and low threshold value to these registers and the STK3101-90H will issue an PS interrupt flag if the actual count stored in registers 0Ahex are outside the user's programmed window. The user must read 0x0A data and write 0 to clear FLG_PS. If the interrupt occurs due to near side (high threshold) and FLG_PS is clear by host, then interrupt will never occur again unless the device moves to far side (low threshold), and vice versa.

PS Interrupt State Diagram

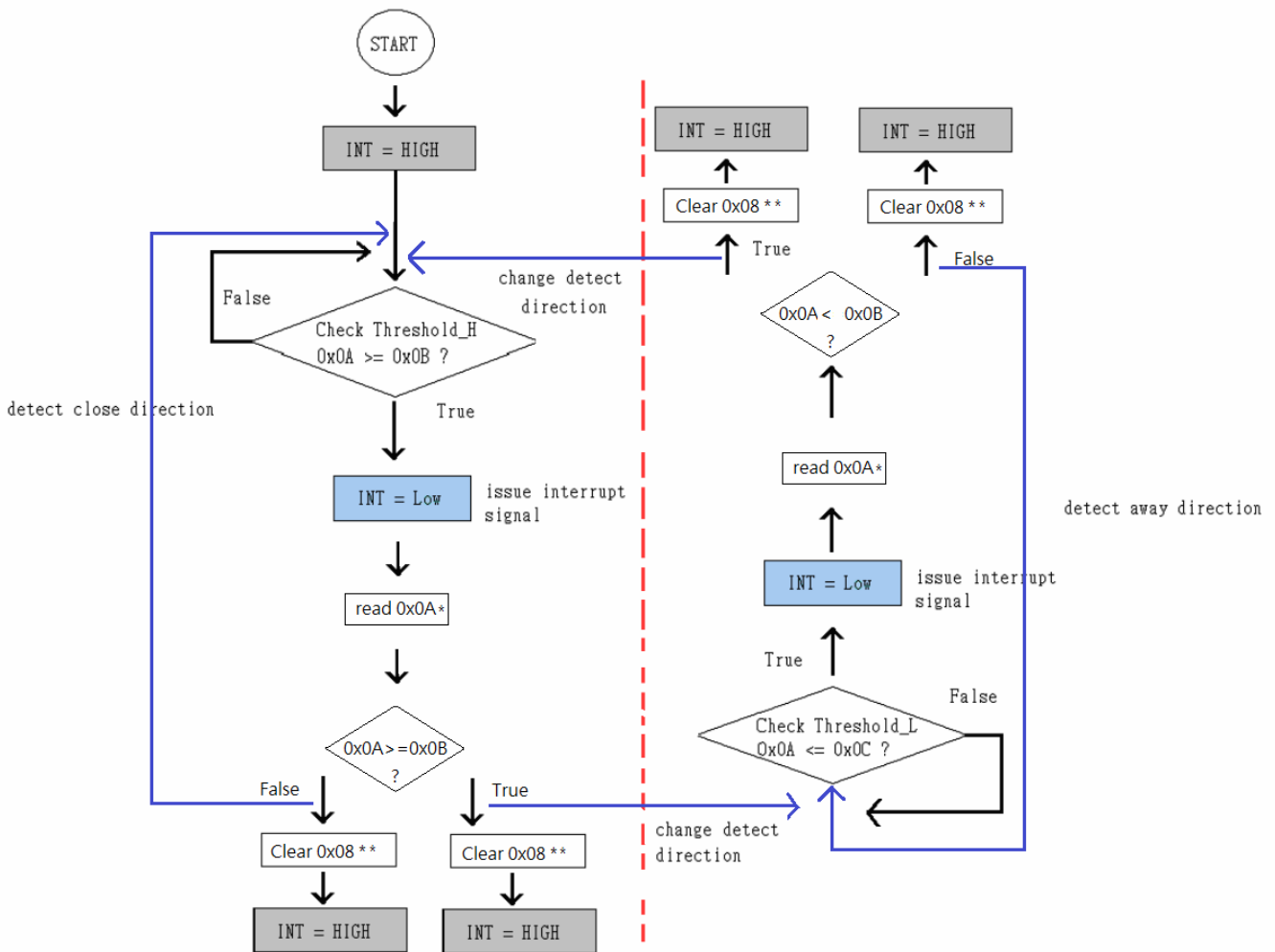

Note: * read 0x0A is driver's behavior and it will trig IC's next action
 ** Clear 0x08 is driver's behavior and it will let INT pin = high

7. ALS RESPONSE CHARTS

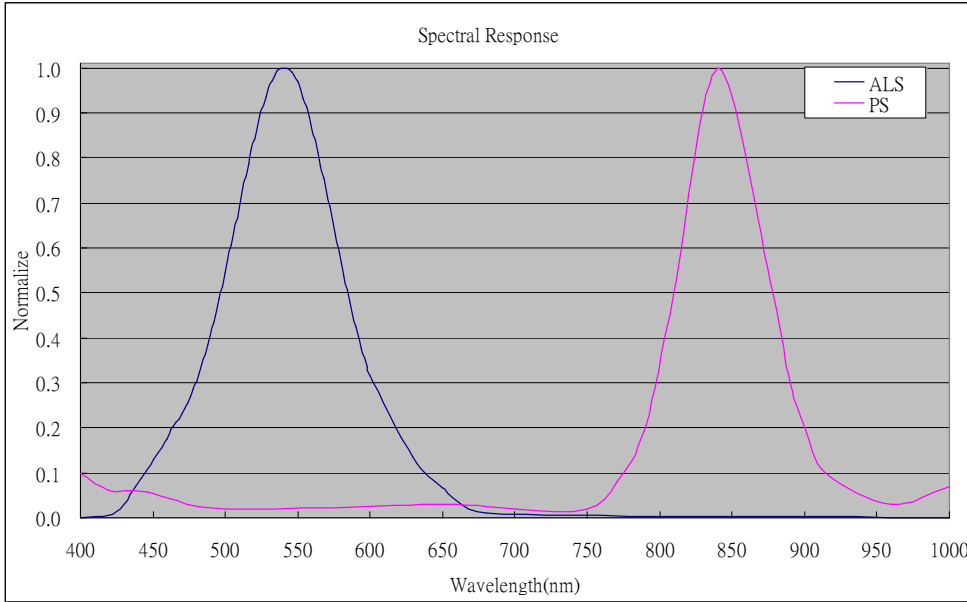

Spectral Response

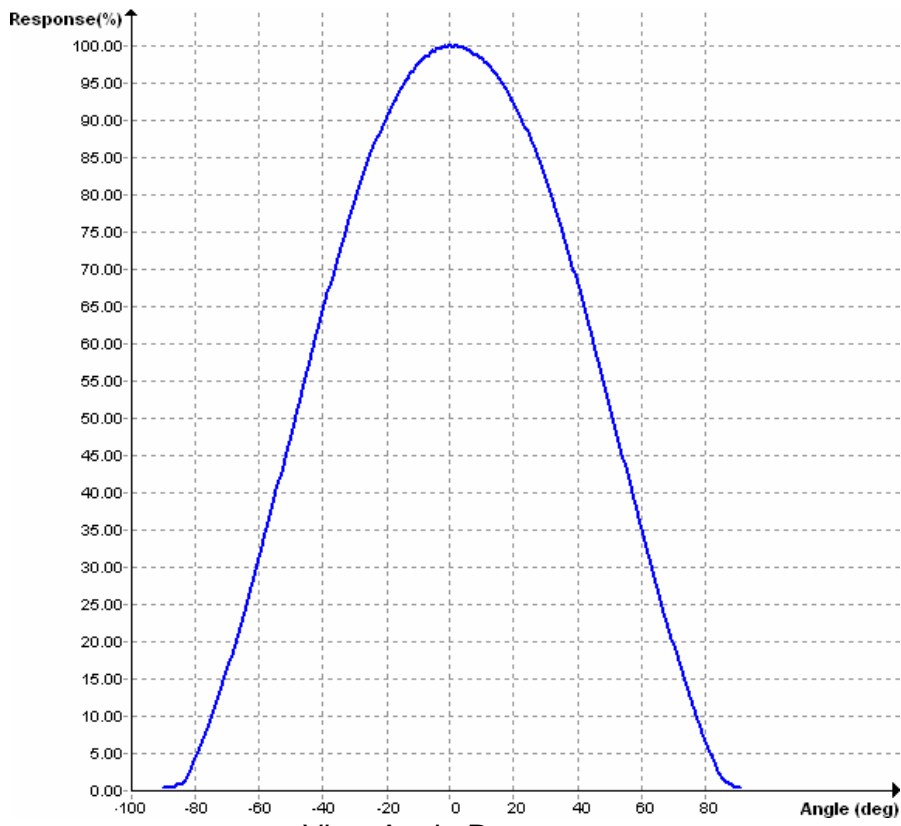

View Angle Response

8. ALS DYNAMIC RANGE

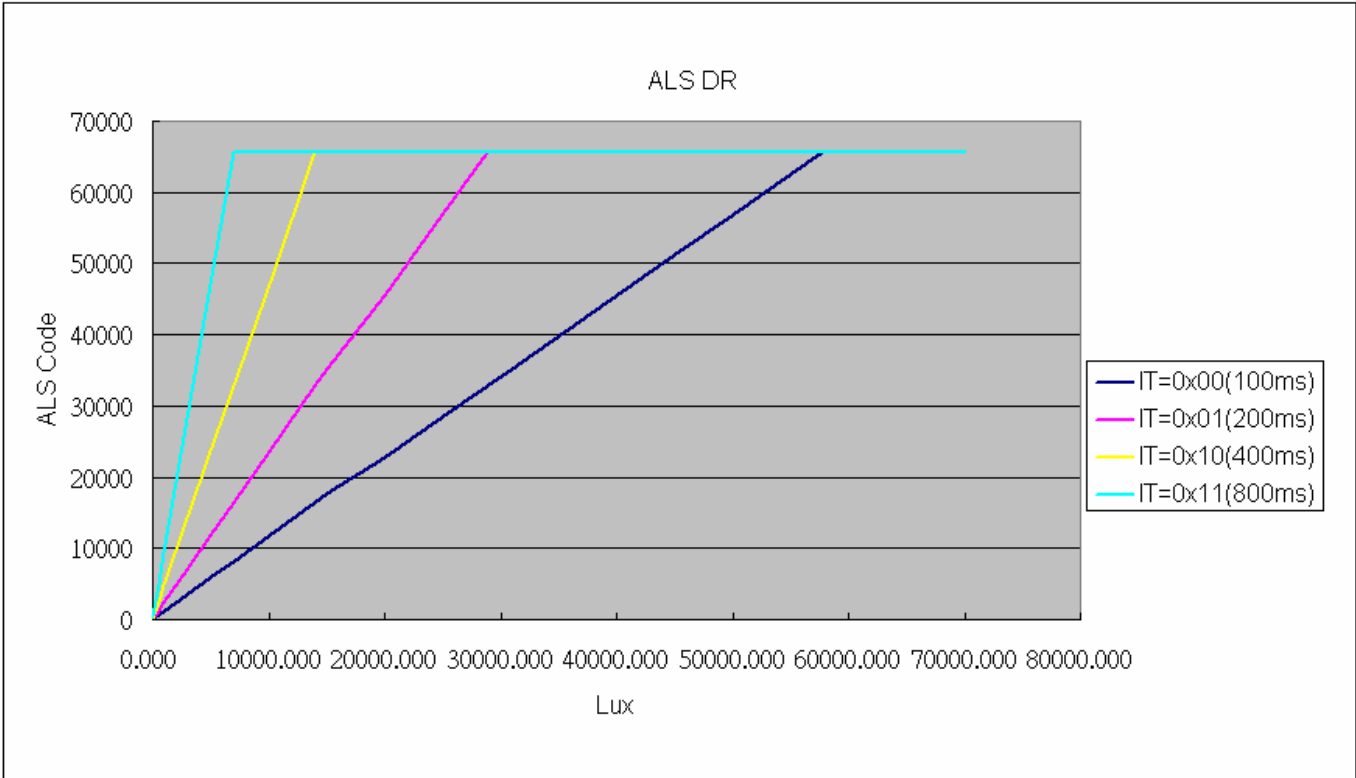

ALS Dynamic Range

9. PROXIMITY CHARACTERISTIC

The STK3101-90H provides high precision measurements for the distance between the object and the sensor. The 256 steps deviation of the PS code can precisely take measurements as the object gets closer to STK3101-90H. The relationship between the STK3101-90H detected object distance and the PS code read out from the I²C interface is shown in the following figure. Once the furthest distance of the object has been confirmed, the continuous distance of each PS code description can be traced along the curved trend.

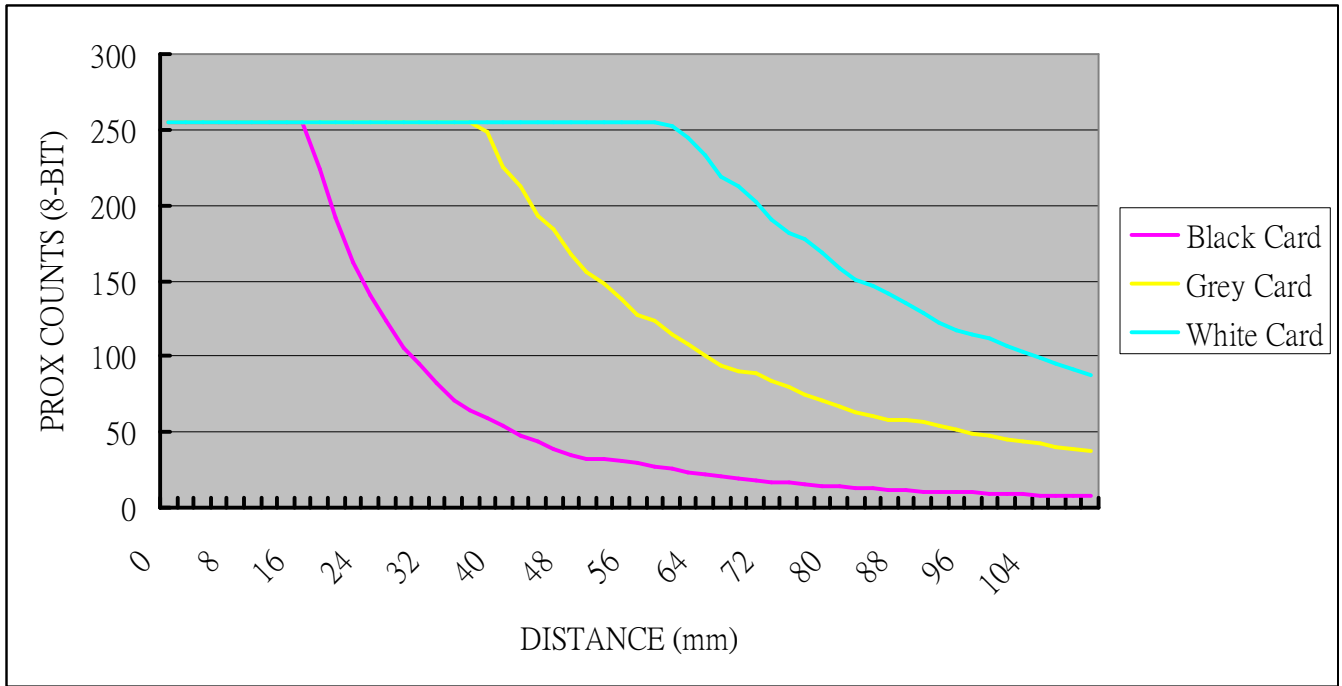

10. PACKAGE OUTLINE

Top View

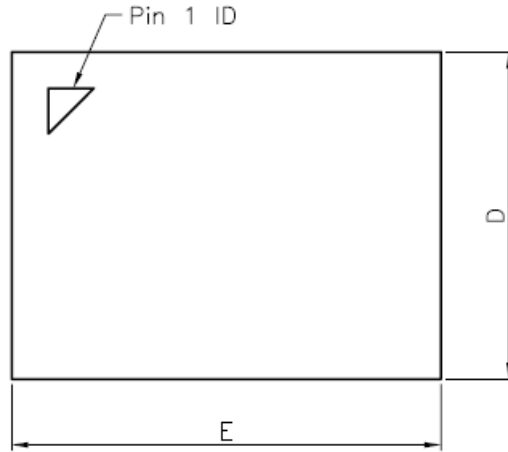

Side View

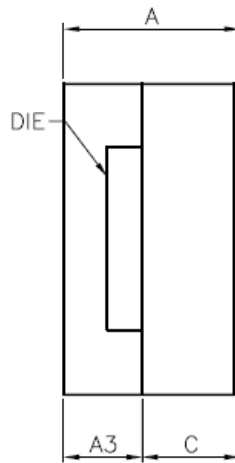

Bottom View

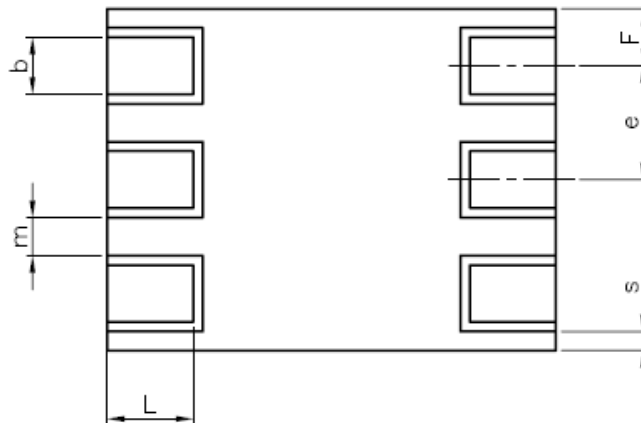

Optical Center Relative to Package Center

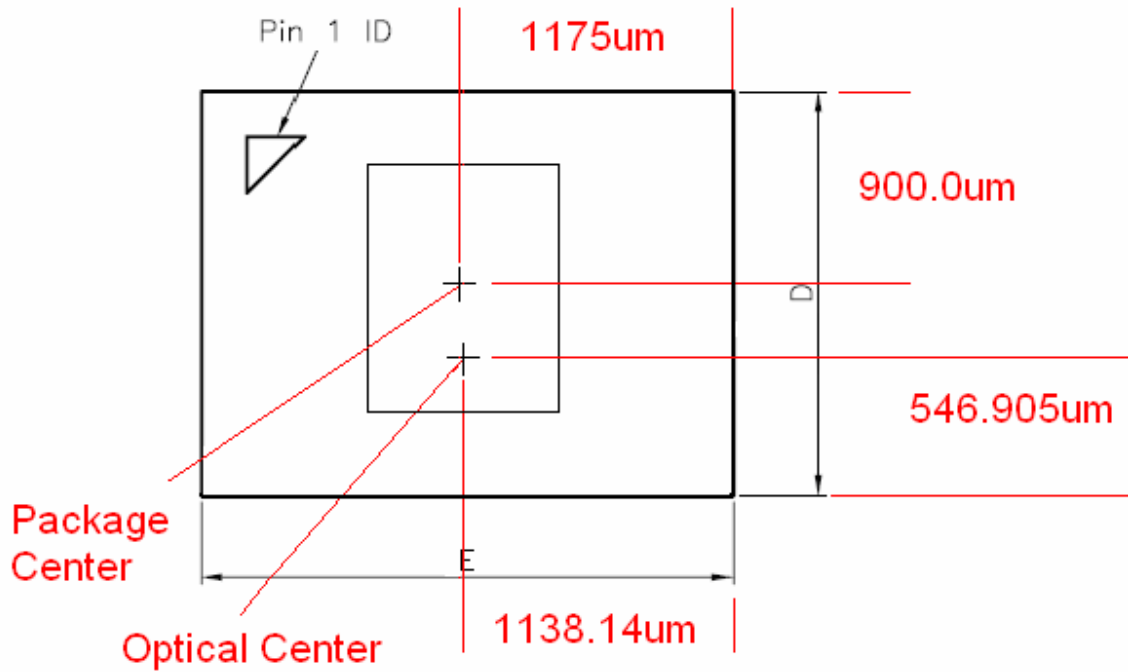

Dimension (unit : mm)

SYMBOLS	DIMENSIONS IN MILLIMETERS		
	MIN	NOM	MAX
A	0.90	1.00	1.10
A3	0.45 REF.		
b	0.20	0.30	0.40
c	0.56 REF.		
D	1.70	1.80	1.90
E	2.25	2.35	2.45
e	—	0.60	—
F	0.20	0.30	0.40
L	0.35	0.45	0.55
s	0.075	—	—
m	0.15	—	—

Reference PCB Layout

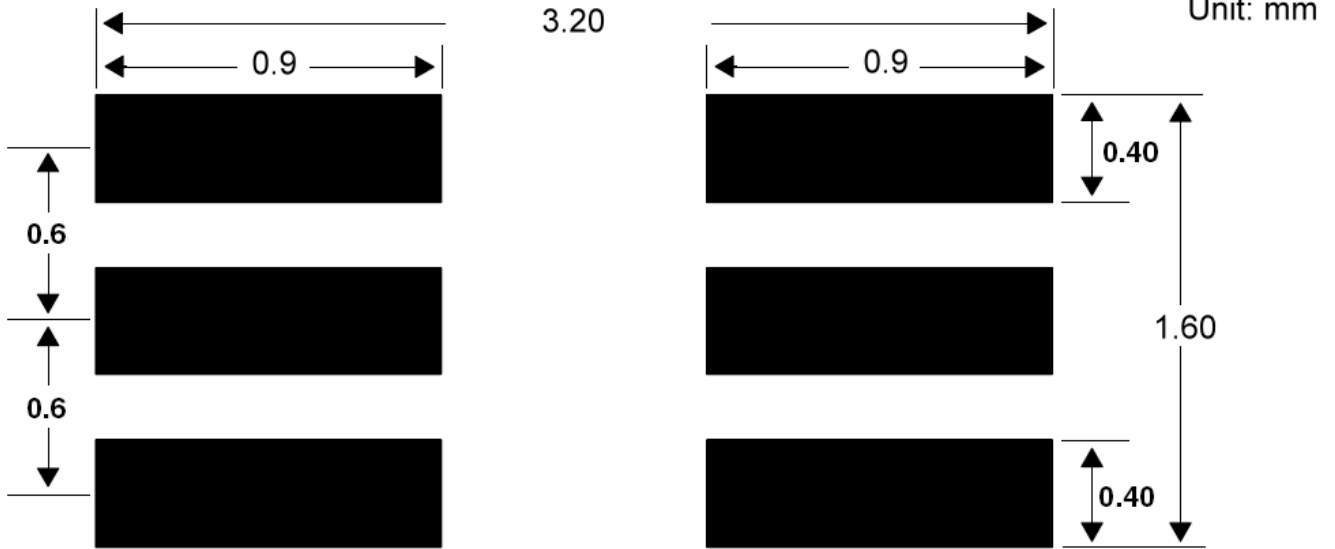

11. TAPE & REEL

Unit: mm

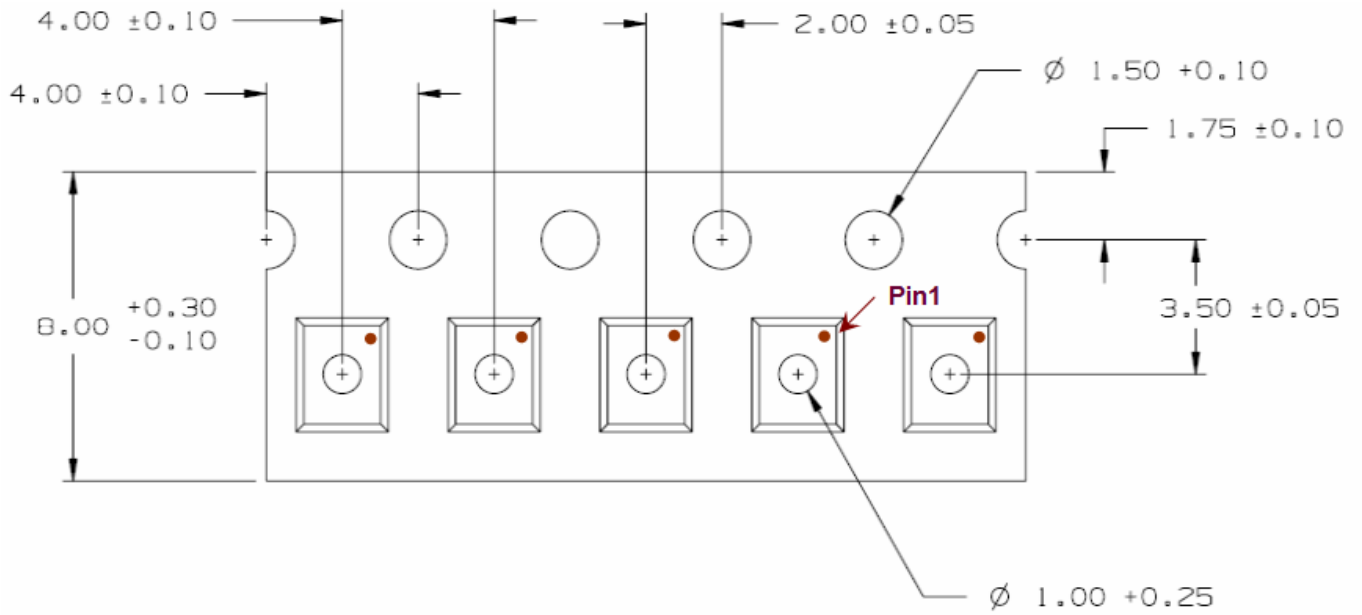

Carrier Tape Dimensions: Loaded quantity 3000 PCS per reel

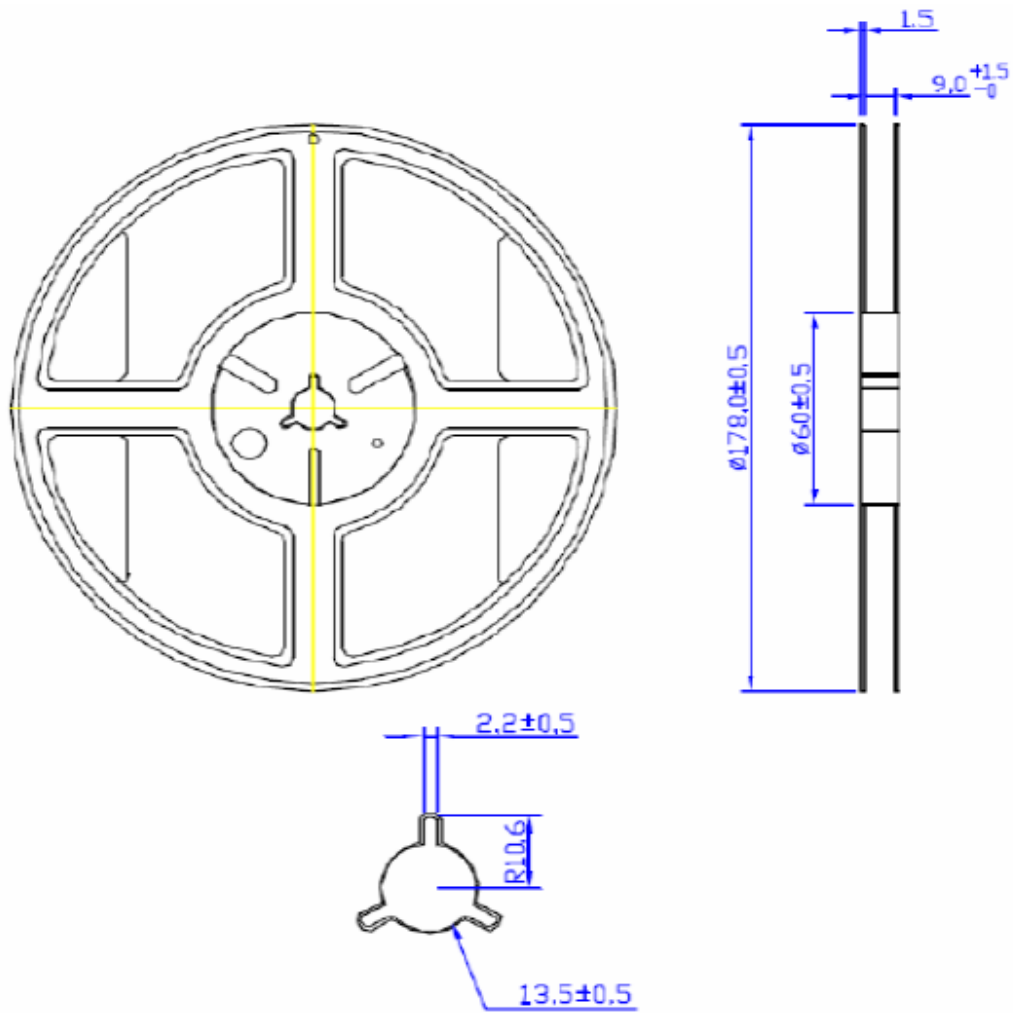

12. APPLICATION CIRCUIT

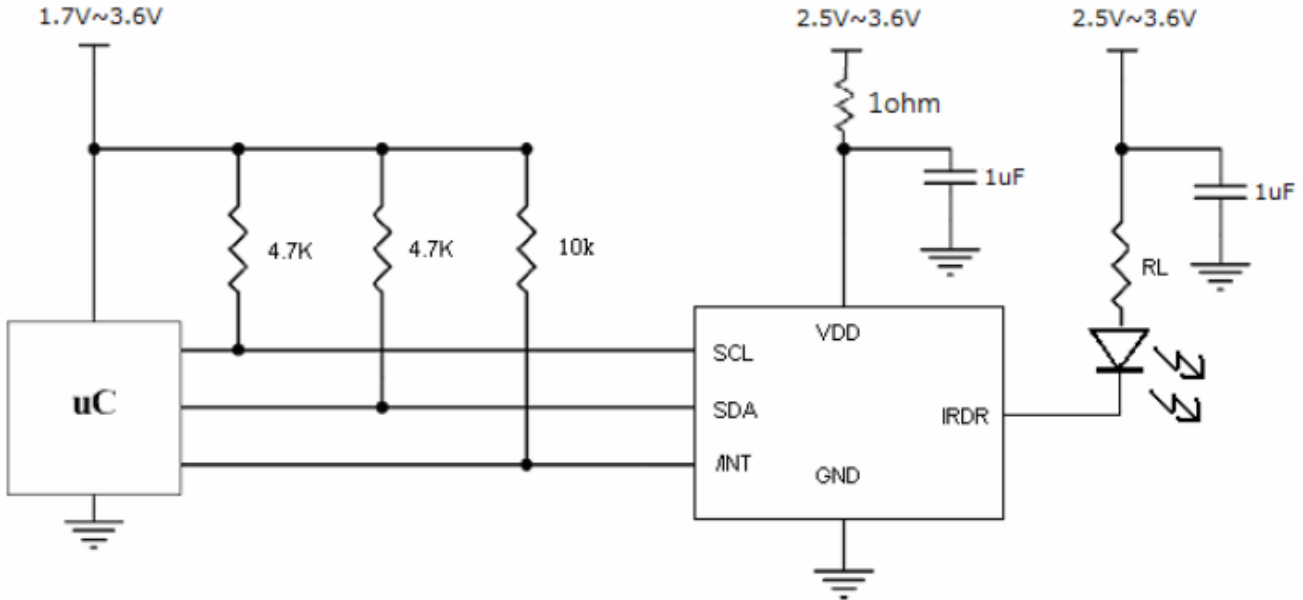

12.1 RL Calculation

Condition 1:

$R_L = 0$, this device provides current source to sink an external IR LED. The sink current can be programmed through IRDR_PS.

$I_f = 200\text{mA}$ with IRDR_PS = 1
 or $I_f = 100\text{mA}$ with IRDR_PS = 0

Condition 2:

RL calculation should consider the following conditions for obtain the realistic value for the application:

- 1). Operation voltage (VDD)
- 2). Forward current (If)
- 3). Forward voltage (Vf)

After these 3 conditions have been confirmed, RL can be calculated by using Vf – If chart and the below equation:

When $I_f > 100\text{mA}$ with IRDR_PS = 1

$$I_f = \left(\frac{V_{DD} - V_f}{R_L + 2} \right), \text{ then } R_L = \left(\frac{V_{DD} - V_f - 2I_f}{I_f} \right)$$

or $I_f < 100\text{mA}$ with IRDR_PS = 0

$$I_f = \left(\frac{V_{DD} - V_f}{R_L + 4} \right), \text{ then } R_L = \left(\frac{V_{DD} - V_f - 4I_f}{I_f} \right)$$

For example:

Assume VDD is 3.3 V, If is 50mA, Vf value can be determined by checking Vf – If chart and it is 1.7V. When IRDR_PS = 0, then RL would be calculated as:

$$R_L = \left(\frac{3.3 - 1.7 - 4 * 0.05}{0.05} \right) = 28\Omega$$

12.2 Soldering Condition

10.2.1 Pb-free solder temperature profile

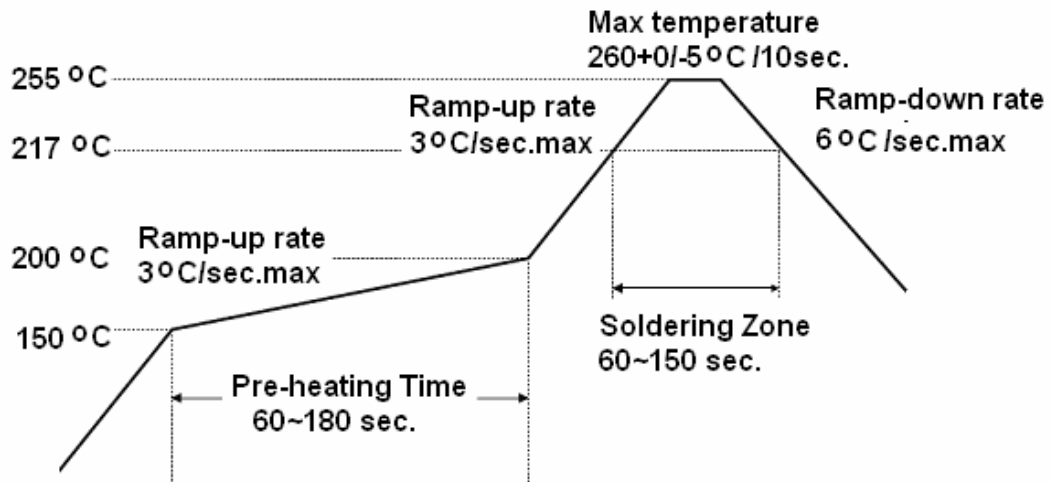

10.2.2 Reflow soldering should not be done more than two times.

10.2.3 When soldering, do not put stress on the LEDs during heating.

10.2.4 After soldering, do not warp the circuit board.

12.3 Soldering Iron

Each terminal is to go to the tip of soldering iron temperature less than 350°C for 3 seconds within once in less than the soldering iron capacity 25W. Leave two seconds and more intervals, and do soldering of each terminal. Be careful because the damage of the product is often started at the time of the hand solder.

5.Repairing

Repair should not be done after the ICs have been soldered. When repairing is unavoidable, a double-head soldering iron should be used (as below figure). It should be confirmed beforehand whether the characteristics of the ICs will or will not be damaged by repairing.

